

Valcourt

Wood fireplace Owner's Manual

Part 2 of 2

INSTALLATION AND OPERATION REQUIREMENTS

DALLAIRE

(FP18R model)

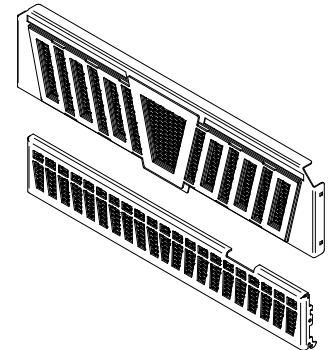
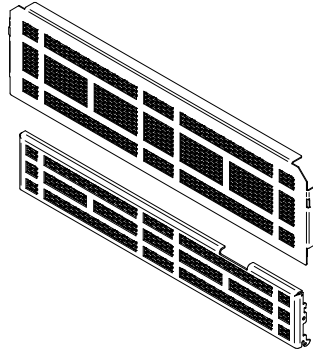
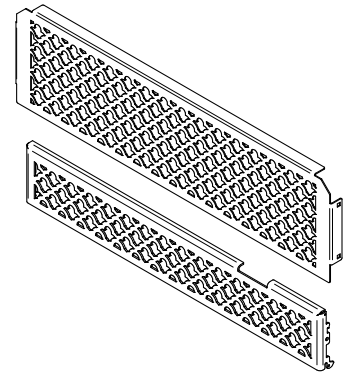
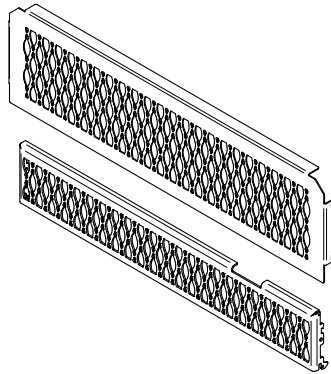
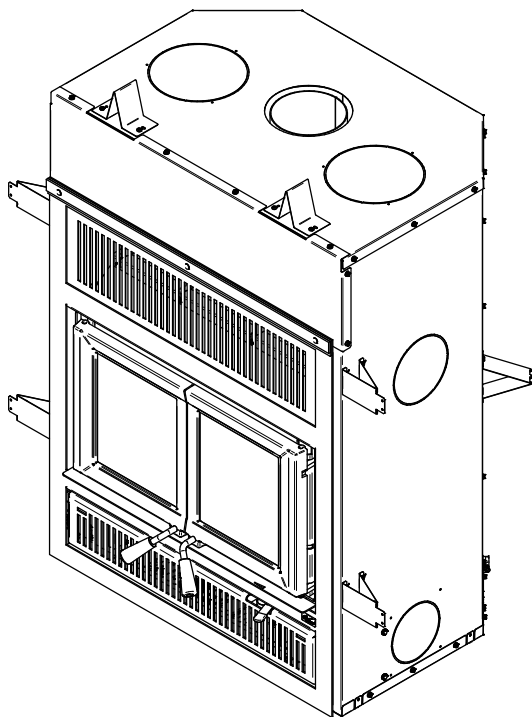

ENGLISH

US Environmental Protection Agency
phase II certified wood fireplace
compliant with 2020 cord wood
standard

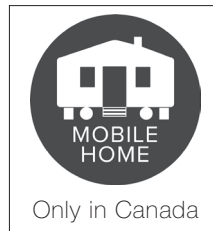

Safety tested according to
ULC S610, and UL
127 standards
by an accredited laboratory.

CONTACT LOCAL BUILDING OR FIRE OFFICIALS ABOUT RESTRICTIONS AND INSTALLATION INSPECTION REQUIREMENTS IN LOCAL AREA.

READ THIS ENTIRE MANUAL BEFORE INSTALLATION AND USE OF THIS WOOD STOVE. FAILURE TO FOLLOW THESE INSTRUCTIONS COULD RESULT IN PROPERTY DAMAGE, BODILY INJURY OR EVEN DEATH.

READ AND KEEP THIS MANUAL FOR REFERENCE

Dealer: _____

Installer: _____

Phone Number: _____

Serial Number: _____

ONLINE WARRANTY REGISTRATION

If the unit requires repairs during the warranty period, proof of purchase must be provided. The purchase invoice must be kept. The date indicated on it establishes the warranty period. If it can not be provided, the warranty period will be determined by the date of manufacture of the product. It is also highly recommended to register the warranty online at

<https://www.valcourtinc.com/en/warranty/warranty-registration/>

Registering the warranty will help to quickly find the information needed on the unit.



TABLE OF CONTENTS

1. General Information	5
1.1 Performances	5
1.2 Specifications.....	6
1.3 Dimensions	7
2. Efficient Wood Combustion.....	10
2.1 Usable firebox volume	10
2.2 Air control	11
2.3 Emission testing certification	12
3. Approved Chimneys	19
4. Fireplace Installation.....	21
4.1 Standoff installation.....	22
4.2 Carrying Handles	22
4.3 Clearances to combustibles.....	23
4.4 Framing construction.....	24
4.5 Hearth Extension Construction	28
4.6 Facing	32
4.7 Shelf Installation	33
5. Chimney Installation	34
5.1 General Advices	34
5.2 Ceiling Supported Installation	38
5.3 Offset Installation	39
5.4 Masonry Chimney Installation	40
5.5 Factory-Built Metal Chimneys in Mobile Homes	41
5.6 Angled Wall Pass-Thru Installation	41
5.7 Chimney Support Installation.....	42
6. Installation of Options on Your Product.....	45
6.1 Faceplate and Louvers installation	45
6.2 Optional Fresh Air Kit Intake Installation	47
6.3 Optional Traditional Gravity Hot Air Distribution Kit Installation.....	51
6.4 Optional Forced Air Distribution Kit Installation.....	55
6.5 Optional Fire Screen Installation.....	56
7. Replacement of Parts on Your Product	57
7.1 Refractory Panels Replacement.....	57
7.2 Secondary Air Tubes and Baffle Installation.....	58
7.3 Mobile Home Installation.....	59
7.4 Blower replacement	60
7.5 Glass Door.....	62
7.6 Door.....	63
7.7 Removing The Air Channel.....	65
8. Exploded Diagram and Part List	66
VALCOURT Limited Lifetime Warranty	70

CERTIFICATION PLATE

ENGLISH



REFER TO INTERTEK'S DIRECTORY OF BUILDING PRODUCTS FOR DETAILED INFORMATION
SE RÉFÉRER AU RÉPERTOIRE DES PRODUITS HOMOLOGUÉS D'INTERTEK POUR PLUS D'INFORMATION

STANDARDS / NORMES D'ESSAI:
 Certified to / Certifié selon CAN/ULC S610
 Certified to / Certifié selon UL 127
 Certified to / Certifié selon CSA B415.1-10
 Certified to / Certifié selon ASTM E2515-11 (R2017)

MODEL / MODÈLE:
DALLAIRE

Serial Number / No. de Série: 99

LISTED FACTORY BUILT FIREPLACE
FOYER PRÉFABRIQUÉ HOMOLOGUÉ

FOR USE WITH / POUR UTILISATION AVEC
WOOD ONLY / BOIS SEULEMENT

CONTACT LOCAL BUILDING OFFICIALS ABOUT THE RESTRICTIONS AND INSTALLATION INSPECTION IN YOUR AREA.
COMMUNIQUER AVEC LES AUTORITÉS LOCALES DU BÂTIMENT ET DE LA PRÉVENTION DES INCENDIES AU SUJET DES RESTRICTIONS D'INSTALLATION DANS VOTRE SECTEUR.

Control Number (LG) : 5007735
(June / Juin 2024)

INSTALL AND USE ONLY IN ACCORDANCE WITH SBI STOVE BUILDER INTERNATIONAL INSTALLATION AND OPERATION INSTRUCTIONS.
L'INSTALLATION ET L'OPERATION DOIT SE FAIRE SELON LES INSTRUCTIONS D'INSTALLATION ET D'UTILISATION DE SBI FABRICANT DE POÊLES INTERNATIONAL.

PREVENT HOUSE FIRES

- Use solid fuel only.
- Combustion air openings shall not be obstructed.
- When doors are used, operate fireplace with doors fully open with fire screen or fully closed only. For safety, keep screen doors or glass doors tightly closed.
- Do not overfire unit.
- Replace with only ceramic glass 4mm thick.
- Use only with listed factory-built chimney as per manufacturer's instructions.
- A non-combustible hearth extension must be installed in front of unit extending 16 in (406 mm) in front and 8 in (203 mm) on each side of door opening.
 - Hearth extension must have a minimum R factor of 1.00. No minimum R factor is required if fireplace is elevated by at least 4 in. (102 mm).
- Do not use a fireplace insert or other products not specified for use with this product.

Areas of the fireplace incorporating warm or cold air ducts shall be enclosed in accordance with manufacturer's instructions.
WARNING: This fireplace has not been tested with an unvented gas log set. To reduce risk of fire or injury, do not install an unvented gas log set into fireplace.
 This wood heater needs periodic inspection and repair for proper operation. Consult the owner's manual for further information. It is against US federal regulations to operate this wood heater in a manner inconsistent with the operating instructions in the owner's manual.

- Suitable for transportable building installation in CANADA only.

PRÉVENEZ LES INCENDIES

- Utiliser uniquement du bois de chauffage.
- Les entrées d'air servant à la combustion ne doivent pas être obstruées.
- Quand des portes sont utilisées, opérer le foyer avec les portes complètement ouvertes ou complètement fermées seulement. Pour votre sécurité, maintenir les portes de grillages ou de vitres fermées de façon étanche.
- Ne pas surchauffer le foyer.
- Remplacer la vitre seulement avec un verre céramique de 4mm d'épaisseur.
- Pour utilisation seulement avec une cheminée préfabriquée homologuée tel que spécifié selon les instructions du manufacturier.
- Une protection de plancher incombustible doit être installée à l'avant du foyer excédant de 16 po (406 mm) à l'avant et 8 po (203 mm) de chaque côté de l'ouverture de porte. La protection à l'avant du foyer doit avoir un facteur R minimum de 1.00. Aucun facteur R n'est requis si le foyer est surélevé d'au moins 4 po. (102 mm).
- Ne pas utiliser de foyer encastrable ou autres produits qui ne sont pas conçus précisément pour être utilisés avec le présent foyer.

Les zones du foyer intégrant des conduits d'air chaud ou froid doivent être installées en accord avec les instructions du manufacturier.
ATTENTION: Ce foyer n'a pas été mis à l'essai avec un ensemble de bûches décoratives à gaz non ventilé. Pour réduire les risques de feu ou de blessures, ne pas installer d'ensemble de bûches décoratives à gaz non ventilé dans ce foyer.
 Cet appareil requiert des inspections et réparations périodiques. Consulter le manuel de l'utilisateur pour plus d'information. Opérer cet appareil de chauffage de façon inconsistente par rapport au manuel de l'utilisateur consiste une violation de la loi fédérale (USA).

- Convient aux bâtiments transportables au CANADA seulement.

MINIMUM CLEARANCES TO COMBUSTIBLE MATERIALS /
DÉGAGEMENTS MINIMUM AUX MATÉRIELLES COMBUSTIBLES

Sidewall / Mur latéral [1] :	21 in (533 mm)	Side facing / Parement latéral [2] :	8 in (203 mm)
Shelf (from floor) / Tablette (du sol) [2][3][4] :	48 in (1219 mm)	Ceiling (from floor) / Plafond (à partir du plancher) [3] :	80 in. (2032 mm)

[1] From door opening. / À partir de l'ouverture de la porte.
 [2] Subject to a maximum protrusion (consult owner's manual). / Sujet à une saillie maximale (consultez le manuel d'instructions).
 [3] If the fireplace is elevated, the clearances to the combustible shelf and ceiling must be increased by an equivalent value. / Si le foyer est surélevé, les dégagements à la tablette combustible et au plafond doivent être augmentés d'une valeur équivalente.
 [4] Consult owner's manual for material to be used. / Consulter le manuel d'installation pour le matériel à utiliser.

Forced air kit / Ensemble d'Air forcé: (115V, 2.4A, 60Hz) # 44121 - Blower / Ventilateur: (115V, 1.4A, 60Hz) # 44207

PROCEDURE TO FOLLOW IN CASE OF RUN-AWAY FIRE

- Keep doors closed
- Close all combustion air controls

EN CAS D'INCENDIE DE CHEMINÉE

- Maintenir les portes fermées
- Fermer tous les dispositifs d'admission d'air

U.S. ENVIRONMENTAL PROTECTION AGENCY Certified to comply with 2020 particulate emission standards using cord wood.
 AGENCE DE PROTECTION DE L'ENVIRONNEMENT DES É.U. (EPA). Conforme aux normes d'émission de particules de 2020 avec bûche de bois.
 Weighted average emission rate / Moyenne pondérée des émissions: 1.9 g/h

Tested and certified in compliance with CFR 40 part 60, subpart AAA, section 60.534(a)(1)(II).

WARNING: This product can expose you to carbon monoxide, which is known to the State of California to cause cancer, birth defects or other reproductive harm.
(For more information go to www.p65warnings.ca.gov)

CAUTION

- HOT WHILE IN OPERATION.
- DO NOT TOUCH. KEEP CHILDREN, CLOTHING AND FURNITURE AWAY.
- CONTACT MAY CAUSE SKIN BURNS. SEE NAME-PLATE AND INSTRUCTIONS.
- THIS FIREPLACE NEEDS AIR FOR GOOD OPERATION.
- WHEN A FIRE IS BURNING IN THE FIREPLACE, FRESH AIR MUST BE SUPPLIED TO THE ROOM WHERE THE FIREPLACE IS LOCATED, FAILURE TO PROVIDE THIS MAY STARVE OTHER FUEL BURNING APPLIANCE FROM AN ADEQUATE AIR SUPPLY.

ATTENTION

- CHAUD EN FONCTIONNEMENT.
- NE PAS TOUCHER. GARDER LES ENFANTS, LES VÊTEMENTS ET LES MEUBLES ÉLOIGNÉS.
- UN CONTACT AVEC LA PEAU PEUT OCCASIONNER DES BRÛLURES. VOIR LES INSTRUCTIONS.
- CE FOYER A BESOIN D'AIR POUR SON BON FONCTIONNEMENT.
- LORSQUE LE FOYER BRÛLE, UN APPORT D'AIR SUPPLÉMENTAIRE DOIT ÊTRE PRÉVU DANS LA PIÈCE, UN MANQUE D'AIR D'APPOINT POURRAIT PRIVER LES AUTRES APPAREILS DE COMBUSTION D'UNE ALIMENTATION D'AIR ADÉQUATE.





Fabricant de poêles international
Stove Builder International

Made in La Guadeloupe, (Qc), Canada
13/11/2024 (# Test)

Fabriquée à La Guadeloupe, (Qc), Canada
13/11/2024 (# Test)
27980

1. General Information

1.1 Performances

Values are as measured per test method, except for the recommended heating area, firebox volume, maximum burn time and maximum heat output.

Model	Dallaire (FP18R)
Fuel Type	Dry Cordwood
Combustion Technology	Non-catalytic
Recommended heating area (sq. ft.) ¹	750 to 2,500 ft ² (70 to 232 m ²)
Overall firebox volume	3.04 ft ³ (0.086 m ³)
Usable Firebox Volume (EPA)	2.61 ft ³ (0.074 m ³)
Maximum burn time	8 hours
Maximum heat output (dry cordwood) ²	85,000 BTU/h (24.9 kW)
Overall heat output rate (min. to max.) ^{2,3}	25,900 BTU/h to 78,200 BTU/h (7.6 kW to 22.9 kW)
Average overall efficiency ³ (Dry cordwood)	65 % (HHV) ⁴
Optimum efficiency ⁵	71.6 % (LHV) ⁶
Optimum heat transfer efficiency ⁷	68.0 % (HHV)
Average particulate emissions rate ⁸	1.9 g/h (EPA / CSA B415.1-10) ⁹
Average CO ¹⁰	1.7 g/min

¹ Recommended heating area and maximum burn time may vary subject to location in home, chimney draft, heat loss factors, climate, fuel type and other variables. The recommended heated area for a given appliance is defined by the manufacturer as its capacity to maintain a minimum acceptable temperature in the designated area in case of a power failure.

² The maximum heat output (dry cordwood) is based on a loading density varying between 15 lb/ft³ and 20 lb/ft³. Other performances are based on a fuel load prescribed by the standard. The specified loading density varies between 7 lb/ft³ and 12 lb/ft³. The moisture content is between 19% and 25%.

³ As measured per CSA B415.1-10.

⁴ Higher Heating Value of the fuel.

⁵ Optimum overall efficiency at a specific burn rate (LHV).

⁶ Lower Heating Value of the fuel.

⁷ The optimum heat transfer efficiency is for the low burn rate and represents the appliance's ability to convert the energy contained in the wood logs into energy transferred to the room in the form of heat and does not take into account the chemical losses during combustion.

⁸ This appliance is officially tested and certified by an independent agency.

⁹ Tested and certified in compliance with CFR 40 part 60, subpart AAA, section 60.534(a)(1)(ii).

¹⁰ Carbon monoxide.

1.2 Specifications

Recommended log length	16 in (406 mm) east-west
Maximum log length ¹¹	20 in (508 mm) east-west
Log length for testing purpose	15.2 ± 0.5 in (386 ± 12.7 mm)
Flue outlet diameter	6 po (150 mm)
Recommended connector pipe diameter	6 po (150 mm)
Type of chimney	ULC-S629, UL 103 HT (2100 °F)
Baffle material	C-Cast
Approved for alcove installation	No
Approved for mobile home installation ¹²	Yes (Only in Canada)
Type of door	Double, glass with cast-iron frame
Type of glass	Ceramic glass
Blower	Included (up to 176 PCM)
Particulate emission standard ¹³	EPA / CSA B415.1-10
USA standard (Safety)	UL 127
Canada standard (Safety)	ULC S610

¹¹ North-south: ends of the logs visible, East-west: sides of the logs visible.

¹² Mobile homes (Canada) or manufactured homes (USA): The US Department of Housing and Urban Development describes “manufactured homes” better known as “mobile homes” as follows; buildings built on fixed wheels and those transported on temporary wheels/axles and set on a permanent foundation. In Canada, a mobile home is a dwelling for which the manufacture and assembly of each component is completed or substantially completed prior to being moved to a site for installation on a foundation and connection to service facilities and which conforms to the CAN/CSA-Z240 MH standard.

¹³ Tested and certified in compliance with CFR 40 part 60, subpart AAA, section 60.534(a)(1)(ii).

1.3 Dimensions

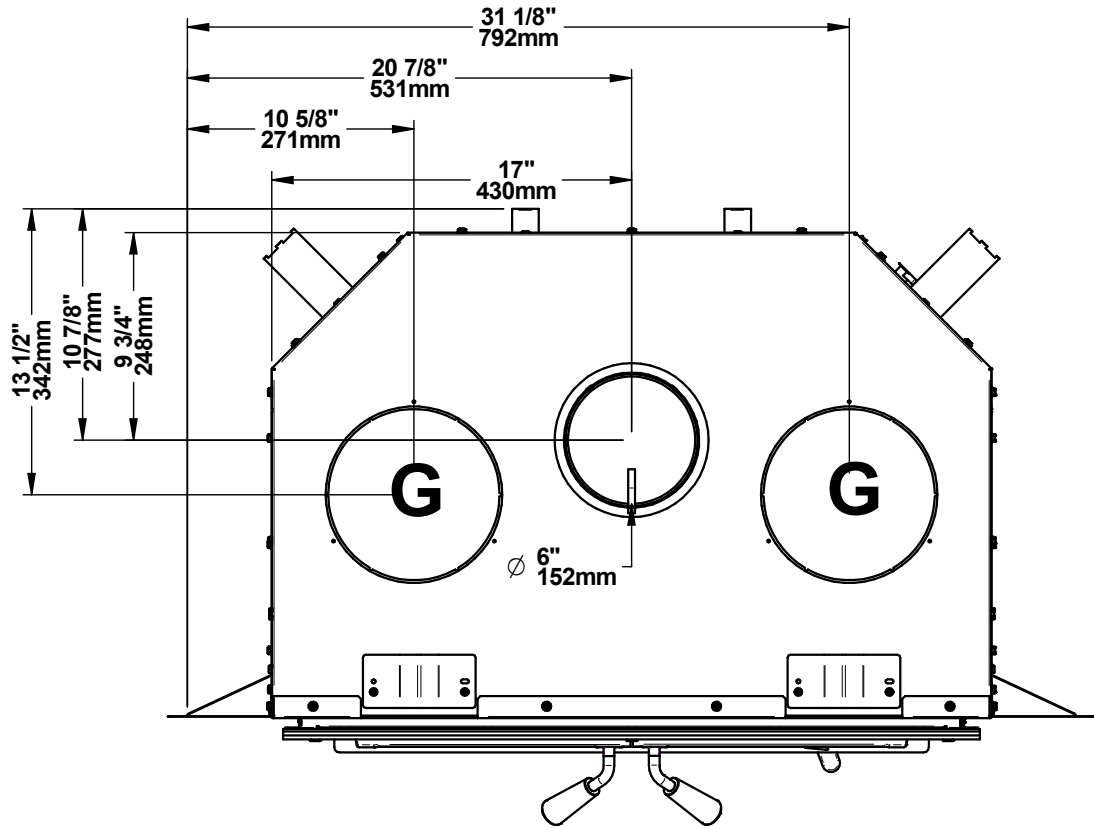

Figure 1: Top View

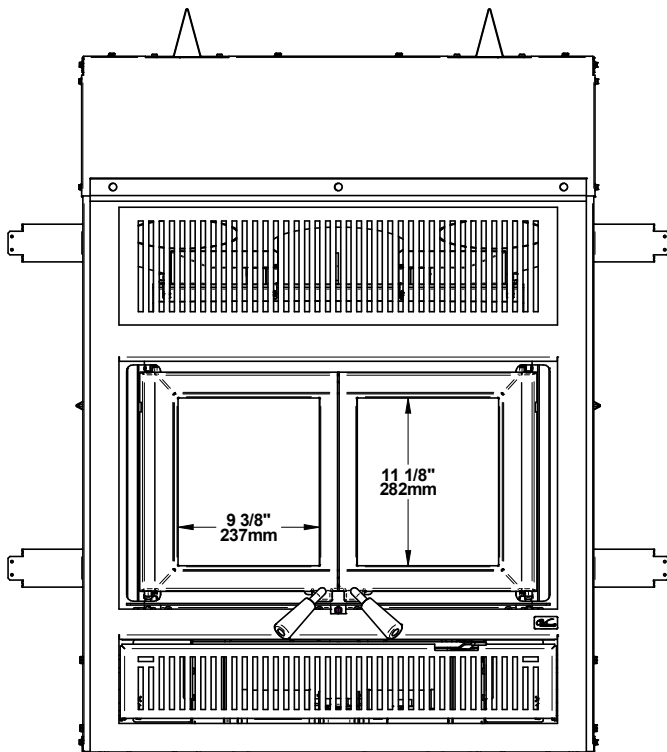

Figure 2: Front View

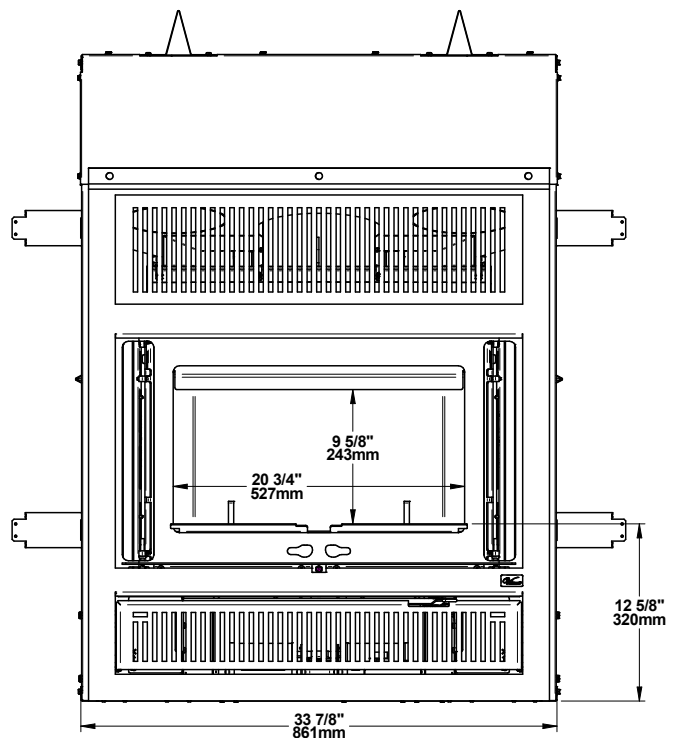

Figure 3: Front View - Door opening

G : Opening for gravity hot air distribution kit (ø 8").

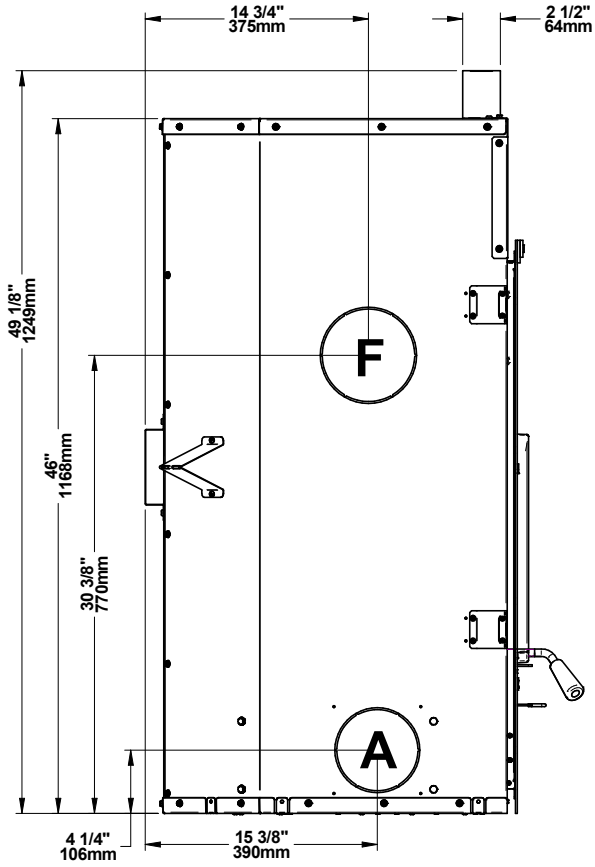

Figure 4: Left side view

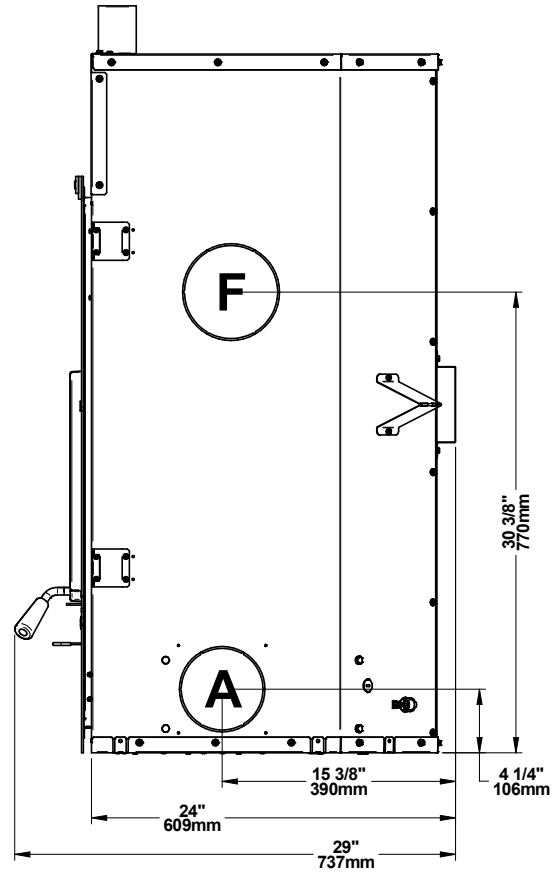

Figure 5: Right side view

- F : Opening for forced air distribution kit (ø 6").
- A : Opening for fresh air intake (ø 4").

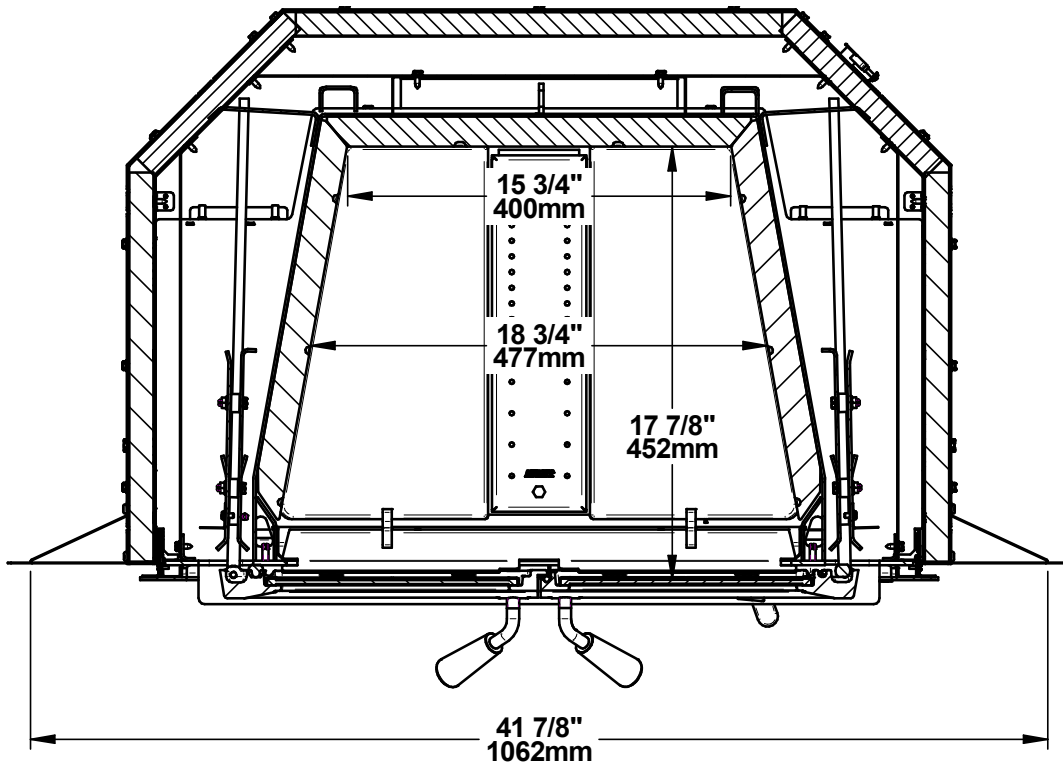

Figure 6: Combustion chamber - Top view

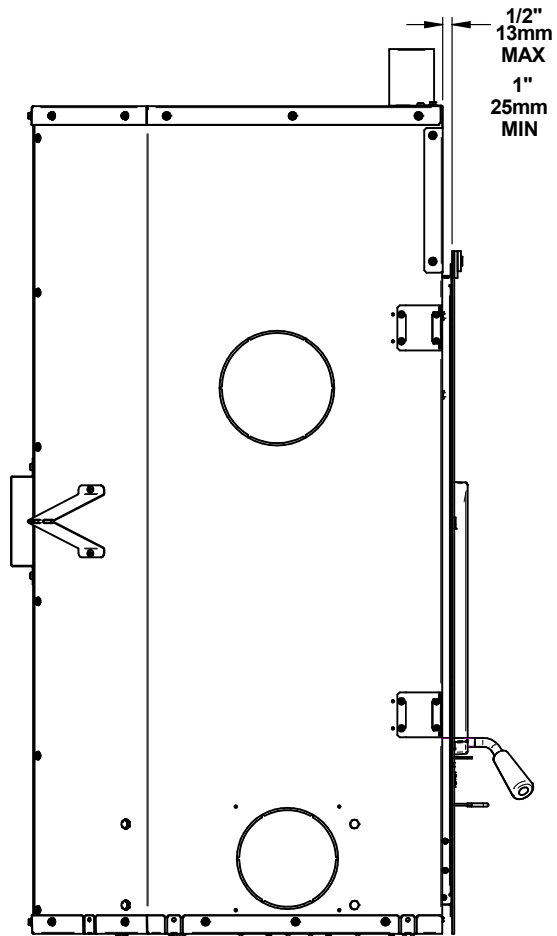

Figure 7: Left view - Faceplate projection

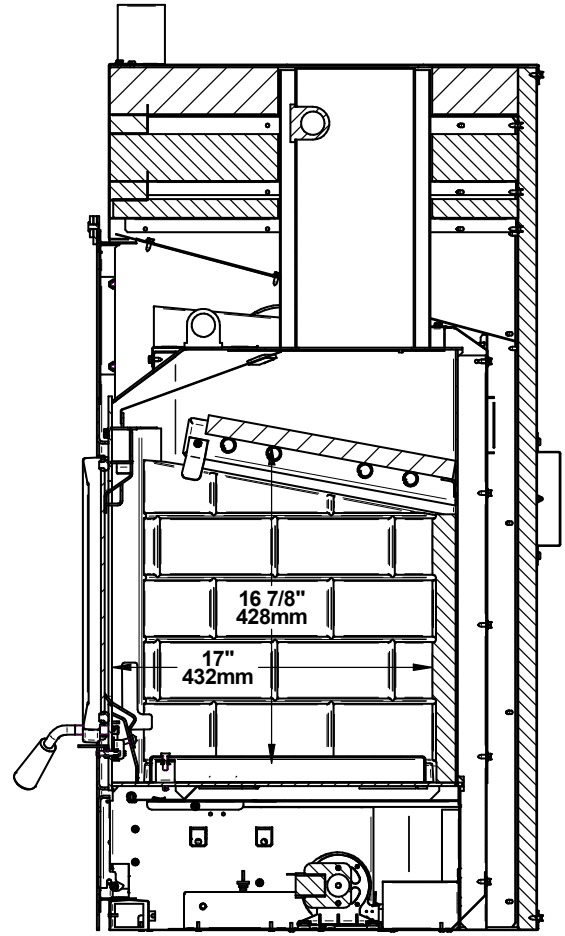

Figure 8: Combustion chamber - Side view

2. Efficient Wood Combustion

2.1 Usable firebox volume

The images below show the space in the firebox where the logs are to be placed. It is important to always respect this space and not to put logs in the grid area marked with an X. This marked area is defined by the space between the glass and the log retainers supplied with the unit. Leave enough space between the logs for good air circulation. Using more than the usable firebox volume for loading wood will result in poor combustion. The Usable firebox volume of 2.61 ft³ shown below is the one used during EPA emissions certification. The recommended log length for this stove is the commercially available length of 16 inches but it was tested, as required by the test procedure, with log length of 15 1/4 inches. The fuel specie used for the EPA certification was Big Leaf Maple.

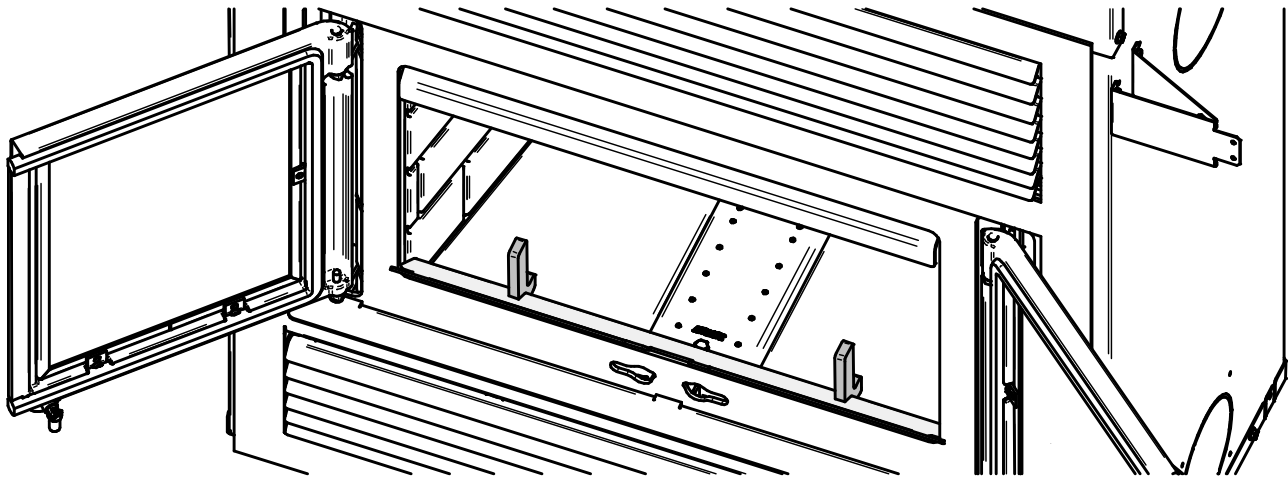

Figure 9: Log retainers

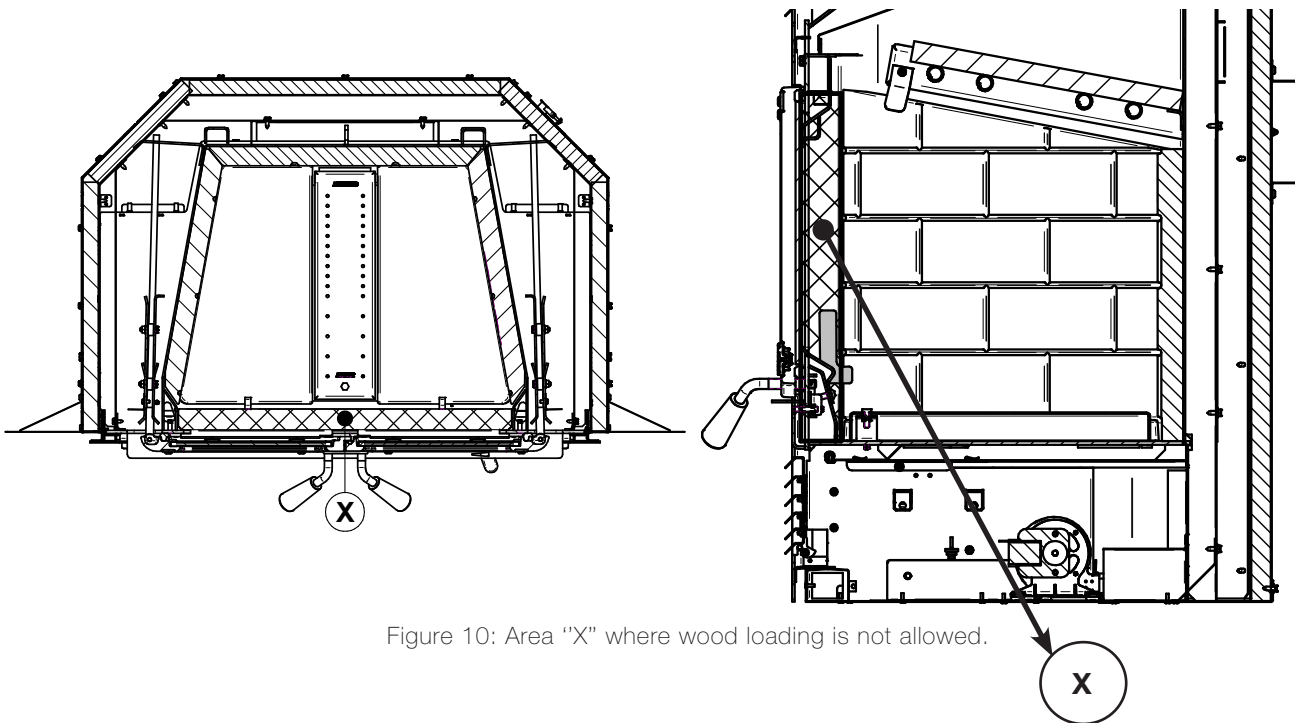

Figure 10: Area "X" where wood loading is not allowed.

The overall firebox calculation is an approximation and is not intended to be used for loading. This volume includes a buffer zone to allow an easier fuel insertion, prevent ash spillage and allow the air wash to work properly.

2.2 Air control

The air control is located underneath the door on the right. To open the air control, push the air control handle completely to the right (High). This will increase the burn rate and the flame intensity. To close the air control, push the air control handle completely to the left (Low). This will permit to achieve the lowest possible burn rate and reduce the flame intensity.

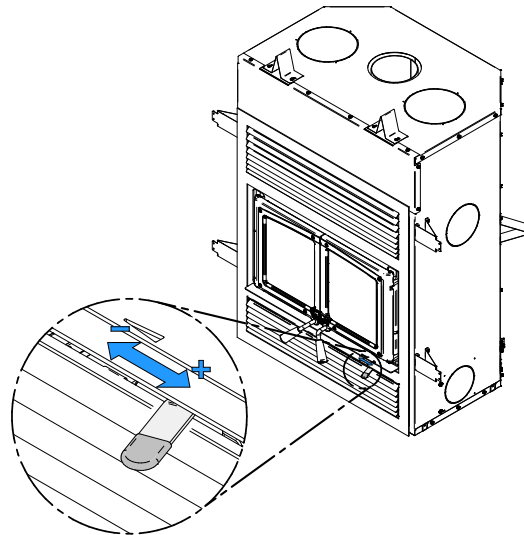

Figure 11: Air control

If the flames decrease to the point of disappearing, it is because the air supply was reduced too early in the combustion cycle, the wood moisture level is too high or the chimney draft is too weak. If the wood is dry, the chimney draft is adequate and the air control is used correctly, the flames should decrease, but remain bright and stable.

However, it is important to note that when the air control is moved to obtain low intensity combustion, it is normal to observe fewer flames in the lower part of the combustion chamber and to see flames appear in the upper part of the combustion chamber near the secondary air tubes.

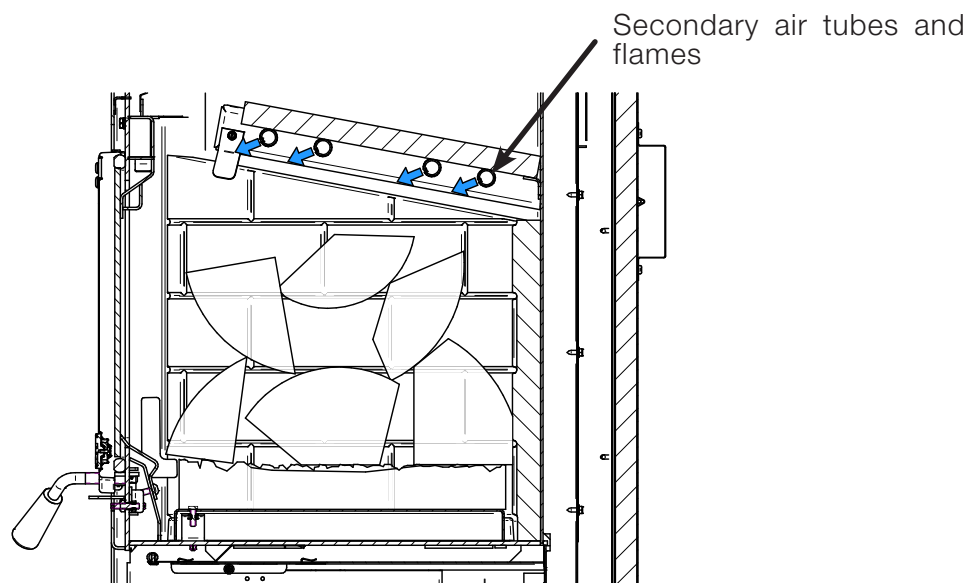

Figure 12: Secondary flame

To reduce particle emissions and minimize clogging of the chimney, it is recommended to reduce the intensity of combustion while preserving the presence of flames around the logs or in the upper part of the combustion chamber near the secondary air tubes.

2.3 Emission testing certification

This section explains how this factory-built fireplace was operated during the emission testing Certification. See the sections below for the description of this testing procedure. It highlights some good practice or methods that can be used in the “real world” for an efficient and clean combustion. However, it is important to verify the following points regarding the utilization of this method.

- During those tests, the unit is operated with hardwood having a low mass density (Big Leaf Maple) with an average wood moisture between 19% and 25% (dry basis). Using wood with higher mass density or higher moisture content may required greater primary air control opening or greater door opening time for a good ignition and maintain efficient combustion. Moisture measurements are made by averaging several measures using a penetration of more than ½ inch. If measurements are made with instrument with less than ¼ inch penetration, it is suggested to split the fuel piece in 2 and to measure on the freshly split face.
- Very Large wood logs or small log quantities (2 or less) can be more difficult to ignite and may required greater primary air control opening or greater door opening time for a good ignition and maintain efficient combustion.
- It is a good practice to observe the flames few minutes just after closing the door or after closing the air control. After a certain period (typically around 10 minutes), verify that the flames are still visible in the firebox with a stable intensity. Refer to section 2.1 and 2.2 above for more details on efficient operation of your fireplace.

WARNING:

- **DO NOT LEAVE THE FIREPLACE UNATTENDED WHILE A NEW LOAD IS BEING FIRED HOT.**
- **DO NOT BUILD THE FIRE TOO CLOSE TO THE GLASS.**

2.3.1 Start-up phase

The air control needs to be fully open. Place newspaper sheets on the firebox floor and carefully criss-cross 15 to 20 kindling pieces of 1"x1" (2.5 cm x 2.5 cm) approximately over the paper in the middle of the firebox. For the best ignition, put the two first kindling pieces in North-South orientation and sit the front tip of the piece on the Kindling Ignition Enhancer (KIE), behind the log retainers. Use those two kindling pieces to support the rest of the kindling pieces. This allows to leave enough space for the paper under the kindling pieces for a better paper ignition. The smaller kindling must be put in the first layer and larger kindling on the other layers over it. In general, leave some air spaces between each kindling pieces and make sure that fuel pieces are not in contact with fire bricks.

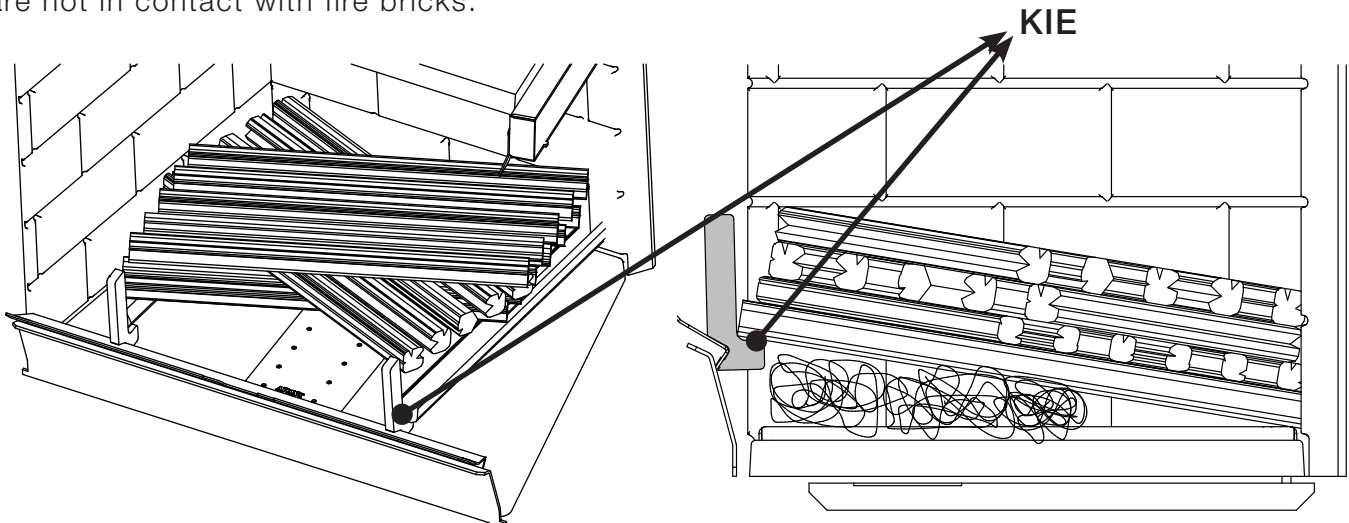

Figure 13: Kindling configuration using Kindling Ignition Enhancer (KIE) - Top view

Figure 14: Kindling configuration using Kindling Ignition Enhancer (KIE) - Side view

The kindling pieces need to be dry with moisture content about 10%. To achieve such a dry condition, we recommend splitting kindling pieces at least 2 weeks in advance, and let it dry in a criss-cross stack, and leave it inside at ambient temperature and low relative humidity. The best practice is to have 2 stacks done first, and, have a rotation of those stack to allow one to dry when you use the dried one.

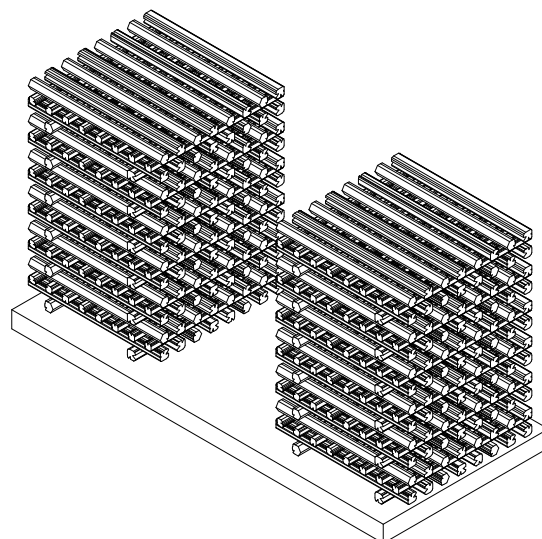

Figure 15: Kindling pieces in a criss-cross stack

Place 5 pieces of start-up fuel of 2 in. x 2 in. (5 cm x 5 cm) approximately over the kindling. For Start-up fuel configuration refer to the picture below. In the same spirit of kindling configuration, use smaller pieces in the first layer and larger on the layer over it. Leave air space between each start-up fuel pieces. Basically, for a good and fast ignition you need to allow the flames to pass all around each wood pieces.

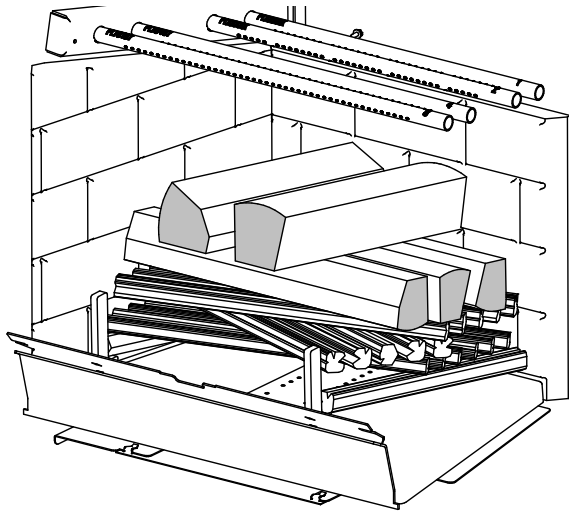

Figure 16: Start-up fuel configuration (over the kindling) -
Top view

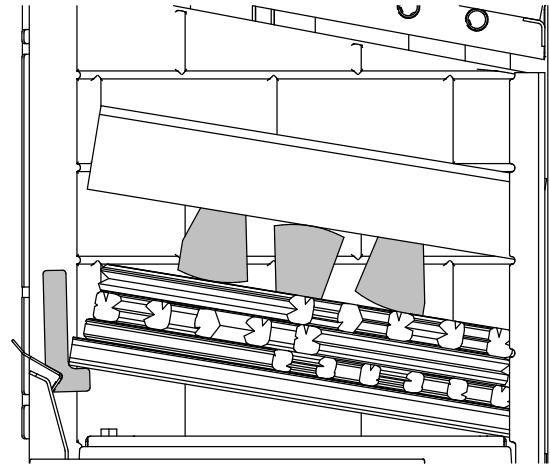

Figure 17: Start-up fuel configuration (over the kindling) -
Side view

Light up the paper at the front and on the side of the fuel load. Using a propane torch will be more efficient (faster) than a small lighter. Let the doors cracked of about one inch. Keep the combustion chamber full of flames between 2 and 3 minutes and close the door when the flames are rolling fast above the fuel load. A fast and very hot ignition will insure an efficient combustion. Keep the air control fully open.



Figure 18: Flames intensity at the beginning of Start-up phase (Door cracked about 1 inch)

2.3.2 High-fire phase

This best time to start this phase is when the unit has a small coal bed, some fuel pieces not completely burn and also when there are still some flames in the combustion chamber. The air control setting is still fully open. This high-fire phase is intended to quickly heat an area, shortly after start-up phase or when restarting the appliance. The High fire load configuration can be made with 5 medium cordwood pieces of 2.5 in. x 4.5 in (6 cm x 11 cm) approximately. Refer to

picture below for a wood load configuration allowing an optimized ignition followed by a stable and clean combustion. In general, medium wood pieces with moisture content between 19% and 25% (dry basis) will be configured in more compact configuration (limited air space between each piece). However, larger wood pieces with a higher moisture content will be configured with more air spaces between each wood pieces.

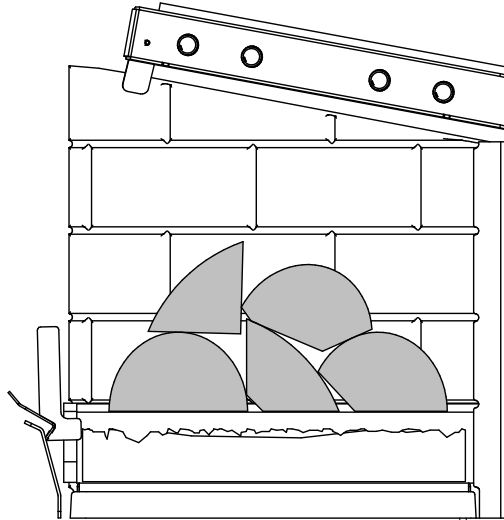

Figure 19: High-fire load configuration with medium size wood pieces

Following the start-up phase, when flames start to reduce in intensity (refer to picture below), open the door and put the first 3 pieces in East-West configuration directly on the unburned wood pieces allowing the primary air to pass under fuel pieces (refer to the picture below). The load needs to be placed in the middle of the firebox without touching the refractory panels. The 2 other pieces should be added on top of the first 3, stacked in the middle, in an East-West orientation.

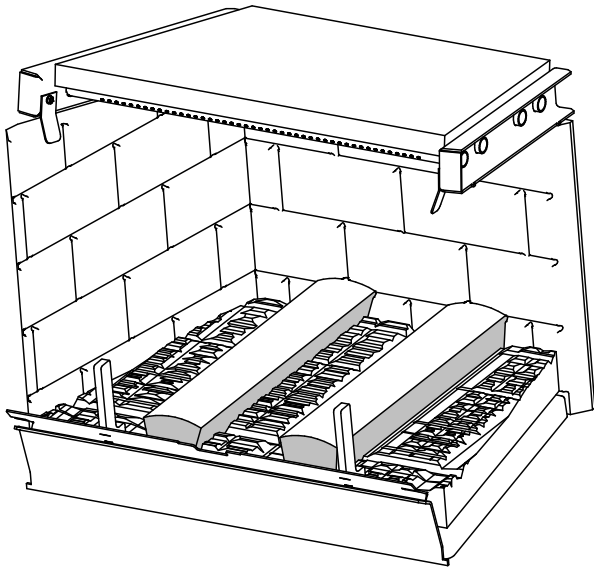

Figure 20: Coal bed and unburned wood pieces before loading the High-fire load

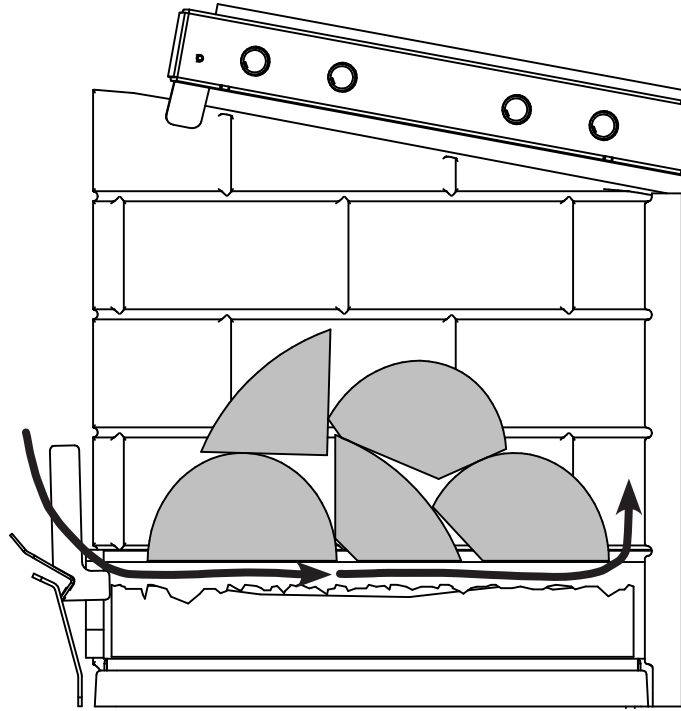

Figure 21: Air path under the High-fire load

Keep the air control fully opened for about half of an hour. That represents approximately when 50% of the load as been consumed. This is when the fire box has reached the maximum temperature, and the flames just begin to reduce in intensity. The air control can be fully or partially closed at that point.

2.3.3 Maintenance-fire phase

This phase is a period when a fire is maintained with a medium-sized coal bed, and a smaller batch of wood normally made of two large cordwood pieces. The goal is to maintain consistent heat output. The Maintenance-fire load configuration is made with 2 larges fuel pieces of 4 in. x 6 in (10 cm x 15 cm) approximately.

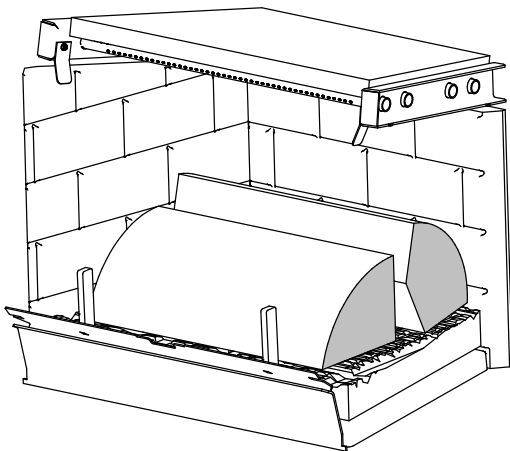

Figure 22: Maintenance-fire load configuration - Top view

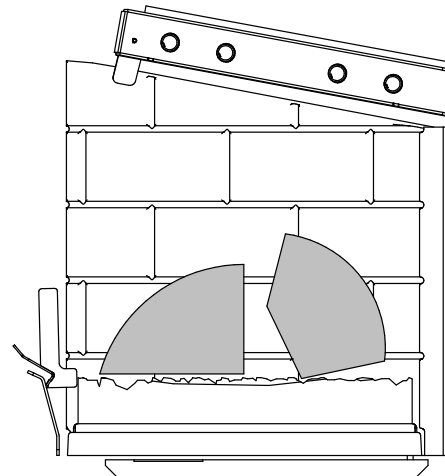

Figure 23: Maintenance-fire load configuration - Side view

Following the high-fire phase, when there are only faint flames remaining and most of the wood is turned into coal, open completely the air control and open the door. The wood pieces can be put gently over the coal bed, and it is not required to stir the coal bed. Put the first piece in East-West orientation at the back of the firebox without touching the refractory panels. Put the second piece just beside the first one also in East-West orientation. Then, close the door and keep the air control fully open for at least 3 minutes. The air control can be fully closed from that point. Make sure flames does not disappear 10-15 minutes after closing the air control.

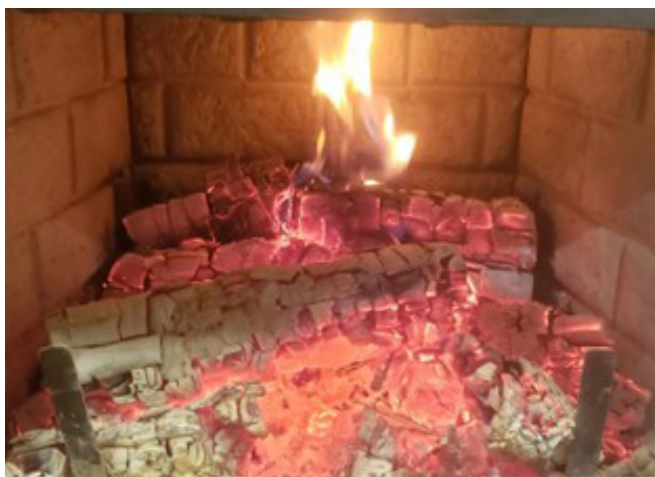

Figure 24: Charcoal bed at the end of High-fire phase



Figure 25: Maintenance-fire load in firebox

ENGLISH

2.3.4 Low-burn rate phase

This phase is a period when the stove has a large coal bed, the stove is fully loaded, and the adjustable air settings are set to produce the lowest possible burn rate. This phase is made to maintain heat over a long time, such as overnight or while away for significant periods of time. The Low-burn rate load configuration is made with 3 large cordwood pieces of 4 in. x 6 in (10 cm x 15 cm) approximately and 3 medium cordwood pieces of 2.5 in. x 4.5 in (6 cm x 11 cm) approximately. The load configuration is East-West.

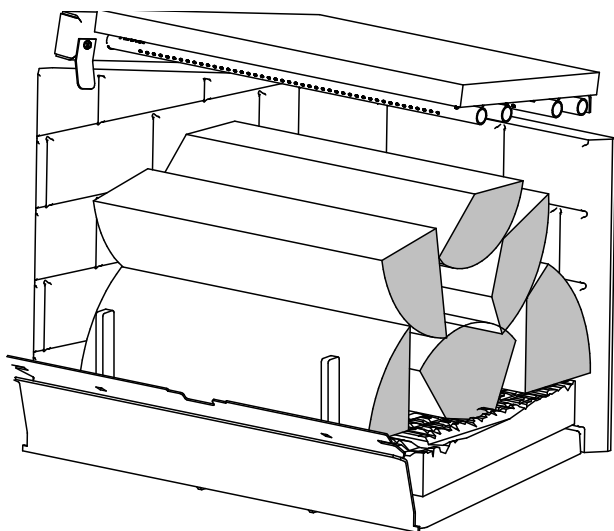

Figure 26: Low-burn rate load configuration - Top view

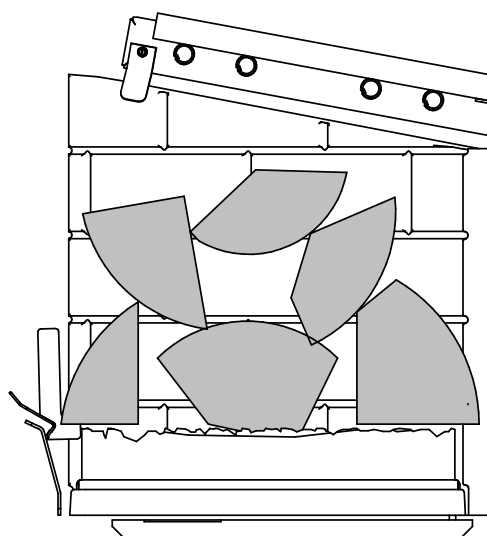

Figure 27: Low-burn rate load configuration - Side view

Following the maintenance-fire phase, when there are only faint flames remaining (or no flames at all) and most of the wood is turned into coal, open completely the air control, open the door and stir the coals slightly to insure ease of wood loading.



Figure 28: Charcoal bed at the end of Maintenance-fire phase



Figure 29: Charcoal bed after stirring

For an optimal loading, put the large wood pieces on the coal bed (first layer) and small pieces over the large pieces of the firebox as shown on the picture above. In general, for large wood load running at low firing rate, maintain air gap between each wood pieces for a faster ignition and an efficient combustion. Make sure that wood pieces are not put over the space between the door glasses and the log retainers (see section 2.1 above). Cordwood pieces at the front of the firebox need to be enough stable to not fall into the door. Proper use of the log retainers can reduce log to roll into the glass door. Let the door cracked of about one inch for at least 3 minutes. Let the flame increase in intensity on each side of the wood load and make sure to ignite completely the top of the wood load (near secondary air tubes) then close the door. Keep the air control fully opened for another 4 minutes minimum and close it partially or completely after that period.



Figure 30: Low-fire load in firebox

3. Approved Chimneys

Table 1 : Approved Chimneys

CHIMNEY MANUFACTURER	MODEL	TYPE	DIAMETER
Olympia Chimney SBI Division Venting	Ventis	1" Solid Pack	6" (15 cm)
SBI Division Venting	Nexvent	1" Solid Pack	6" (15 cm)
Olympia Chimney	Champion Chimney System	1" Solid Pack	6" (15 cm)
Olympia Chimney	Rockford Chimney Systems	1" Solid Pack	6" (15 cm)
Selkirk	CF Sentinel (CF)	2" Solid Pack	6" (15 cm)
Selkirk	Super Pro 2100 (ALT)	2" Solid Pack	6" (15 cm)
Selkirk	Super Vent 2100 (JM)	2" Solid Pack	6" (15 cm)
Security Chimney	S-2100 +	2" Solid Pack	6" (15 cm)
DuraVent	Dura Tech	1" Solid Pack	6" (15 cm)
DuraVent	Dura Tech Canada DTC	1" Solid Pack	6" (15 cm)
DuraVent	DuraPlus HTC	2 "Solid Pack	6" (15cm)
DuraVent	Dura Tech Premium	2" Solid Pack	6" (15 cm)
DuraVent	Dura Plus	AC Triple Wall	6" (15 cm)
Metal Fab	Temp Guard	1" Solid Pack	6" (15 cm)
American Metal	HSS	AC Triple Wall	6" (15 cm)
American Metal	HS	AC Triple Wall	6" (15 cm)

Table 2 : List of mandatory components

CHIMNEY MANUFACTURER	MANDATORY COMPONENTS	TYPE/MODEL
Olympia Chimney / SBI Venting Division	<ul style="list-style-type: none"> Ventilated roof flashing. 	1" Solid Pack : Ventis, Nexvent, Champion Chimney System, Rockford Chimney Systems
Security Chimney	<ul style="list-style-type: none"> Requires insulated attic radiation shield unless chimney is enclosed at the attic level. 	2" Solid Pack: S-2100
DuraVent	<ul style="list-style-type: none"> Ventilated roof flashing. 	1" Solid Pack: Dura Tech, Dura Tech Canada DTC 2" Solid Pack: Dura Tech Premium
American Metal	<ul style="list-style-type: none"> Chimney cannot be enclosed at the attic level. 	AC Triple wall : HS AC Triple wall : HSS

ENGLISH

3.3.1 Rafter protection

Rafter protectors, at the roof level, must be installed with this unit, if the chimney is enclosed at the attic level. Rafter protectors must be made of 22 ga or more galvanized steel and must have at least the dimension presented on the following diagram:

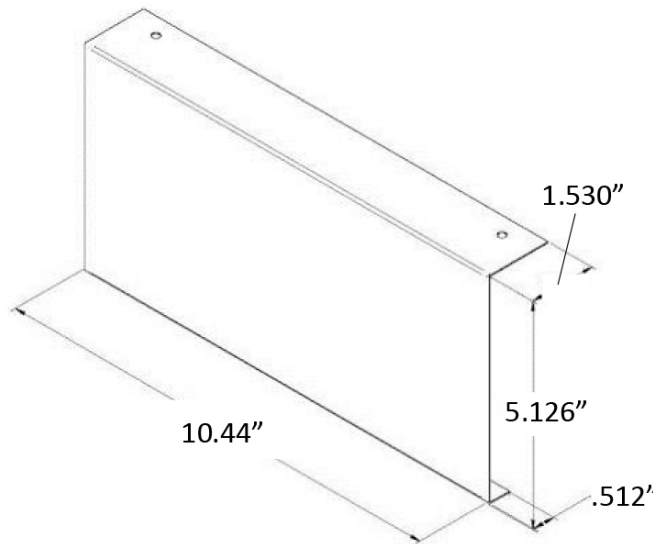

4. Fireplace Installation

Install the fireplace only as described in these instructions and using only the following fireplace components and chimney components from chimney manufacturers listed in "[Table 1 : Approved Chimneys](#)".

- Fireplace;
- Faceplate and louvers;
- Overlay;
- Refractory panels;
- Insulated chimney made by the manufacturers listed in [Table 1](#), with the corresponding specifications:
 - Chimney lengths;
 - Elbows (where necessary);
 - Associated components as per these installation instructions.

Additional Equipment (optional)

- Forced air distribution kit;
- Traditional or modern gravity hot air distribution kit;
- Fresh air kit;
- Fire Screen;
- Heat shield for combustible shelf.

4.1 Standoff installation

Before installing the fireplace, **it is mandatory to install the standoffs** on the top **(L)** , on the sides and **(O)** and **(P)** the back **(N)** of the fireplace. The standoffs can be found in the fireplace firebox and the screws **(M)** to install them can be found in the fireplace manual.

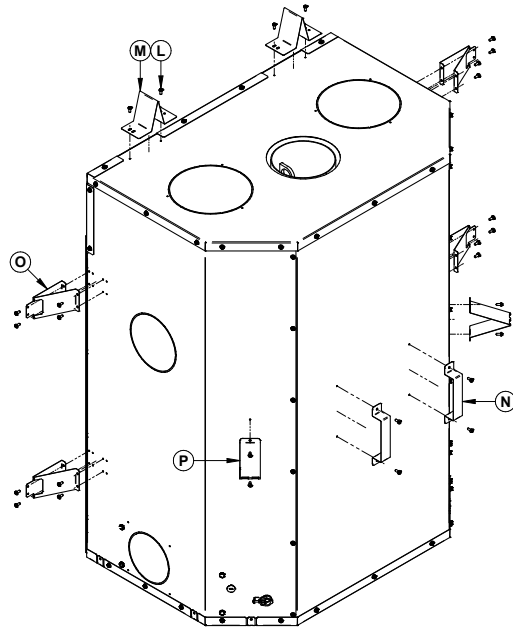

4.2 Carrying Handles

To facilitate the transport of the fireplace, handles sold as an option may be used. They are installed on each side of the fireplace. Wearing gloves is strongly recommended when moving the fireplace.

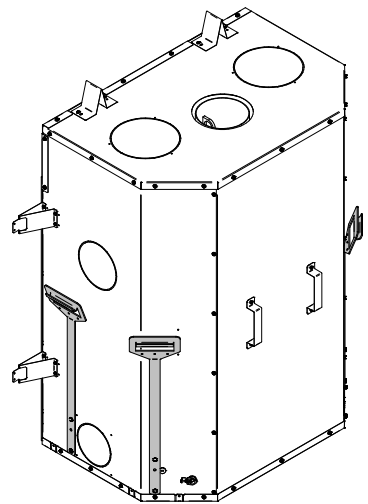

4.3 Clearances to combustibles

The clearances shown in this section have been determined by test according to procedures set out in safety standards ULC S610 (Canada) and UL127 (U.S.A.). When the fireplace is installed so that its surfaces are at or beyond the minimum clearances specified, combustible surfaces will not overheat under normal and even abnormal operating conditions.

A material is considered non-combustible when made entirely of steel, iron, bricks, tiles, concrete, slate, glass or a combination of these materials. Materials corresponding to ASTM E136 and UL 763 are considered to be non-combustible materials with the exception of gypsum, which will be considered a non-combustible material only if it is certified to withstand an ambient temperature of use of 250°F and more.

No part of the fireplace may be located closer to the combustible than the minimum clearance given.

- Maximum mantle depth 3" (76 mm)
- Mantle minimum distance 8" (203 mm) (measured from the door opening)
- Side wall distance 21" (533 mm) (measured from the door opening)
- Minimum distance to the wall in front of the fireplace 48" (1219 mm) in Canada and 36" (914 mm) in USA.
- Minimum ceiling height : 80" (2032 mm) measured from the base of the fireplace.

Fireplace enclosure :

- Back wall : 0"
- Sides : 0"
- Floor (underneath the fireplace) : 0"
- Chimney : 2" (51 mm)

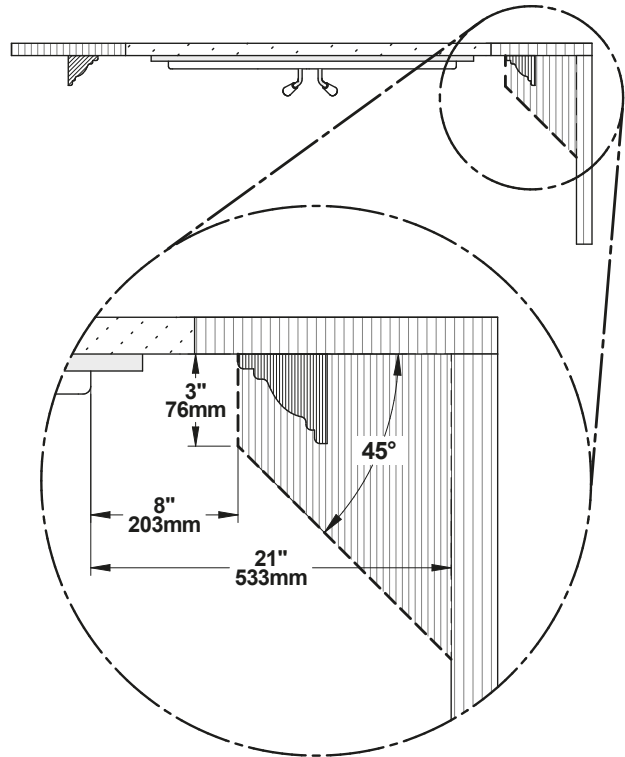

4.4 Framing construction

The frame, on the sides and back of the fireplace, must be made of 2" x 3" (5 cm x 8 cm) or larger. The front studs as well as headers on top of the fireplace must be of a depth no more than the depth of the top standoffs. The standoffs can be installed either flush with the fireplace or setback of 1/2" (13 mm) depending on the thickness of the finishing material used.

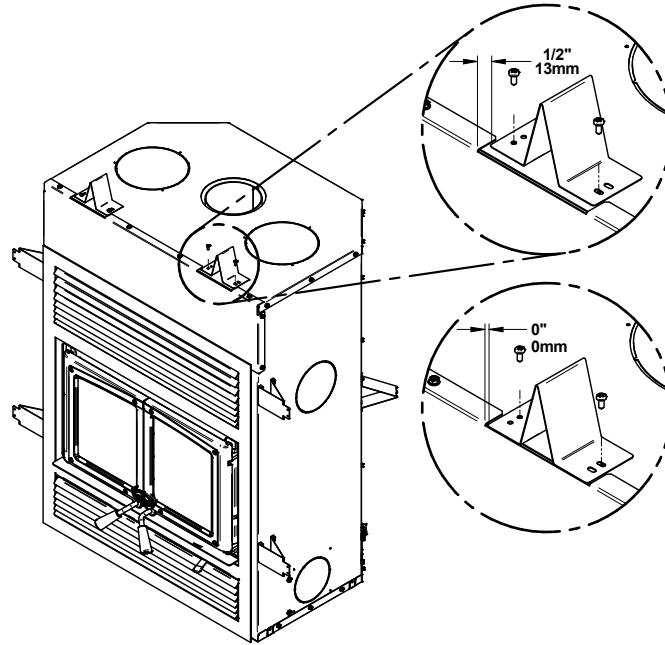

Do not use combustible materials for the frame directly above the fireplace. This area should remain empty to a height of 80" (2032 mm) measured from the base of the fireplace.

Build the fireplace frame using vertical studs placed on the sides of the fireplace, from the floor to the ceiling. The studs must be set back from the front edge of the fireplace by a space equivalent to the thickness of the finishing material, so that it is flush with the finish of the fireplace.

Headers between studs should be installed as follows:

- The headers must be 2" x 3" (5 cm x 8 cm) or 2" x 4" (5 cm x 10 cm). Do not put wood or other material in the area above the fireplace.
- Install only the cripple studs needed to support the finishing material and mantle.

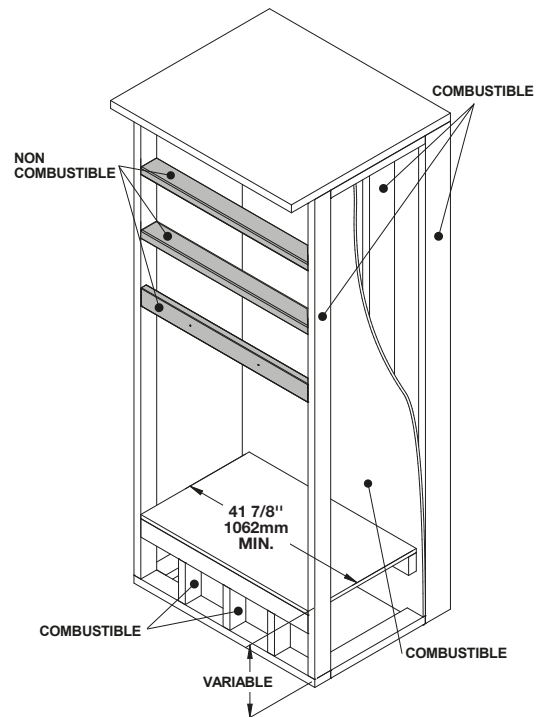

4.4.1 Fireplace Framing

WARNING :

- **DO NOT FILL THE REQUIRED EMPTY SPACE INSIDE THE ENCLOSURE WITH INSULATION OR ANY OTHER MATERIAL.**
- **DO NOT PUT STORAGE SPACE IN THE ENCLOSURE SURROUNDING THE FIREPLACE.**

Framing dimensions should be used as a reference only.

The fireplace must not be in contact with any insulation or loose filling material. Inside the chase, around the fireplace, insulation should be covered with drywall panels or any other finishing material except where non-combustible material is required.

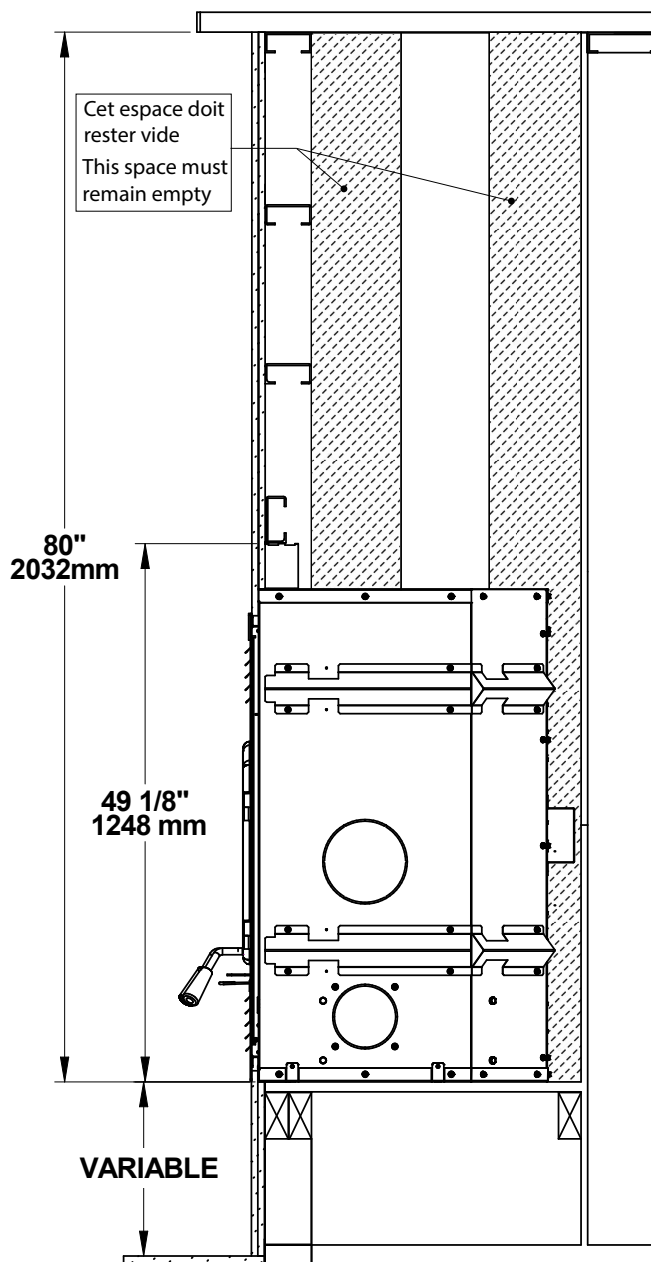

If a finishing material is installed inside the enclosure, its thickness must be added to the following measurements.

- Framing width 41 7/8" (1062 mm)
- Framing height to the first header 49 5/8" (1260 mm)
- Framing depth 24 1/2" (622 mm)
- Framing total height 80" (2032 mm)

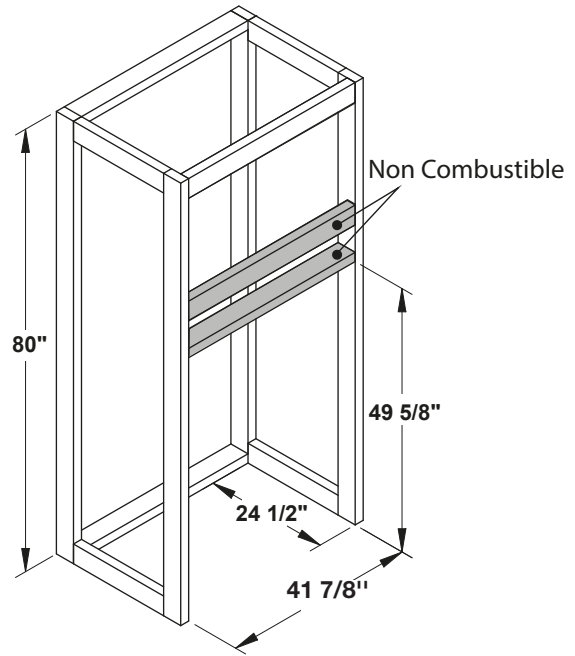

4.4.2 Framing with gravity air kit install

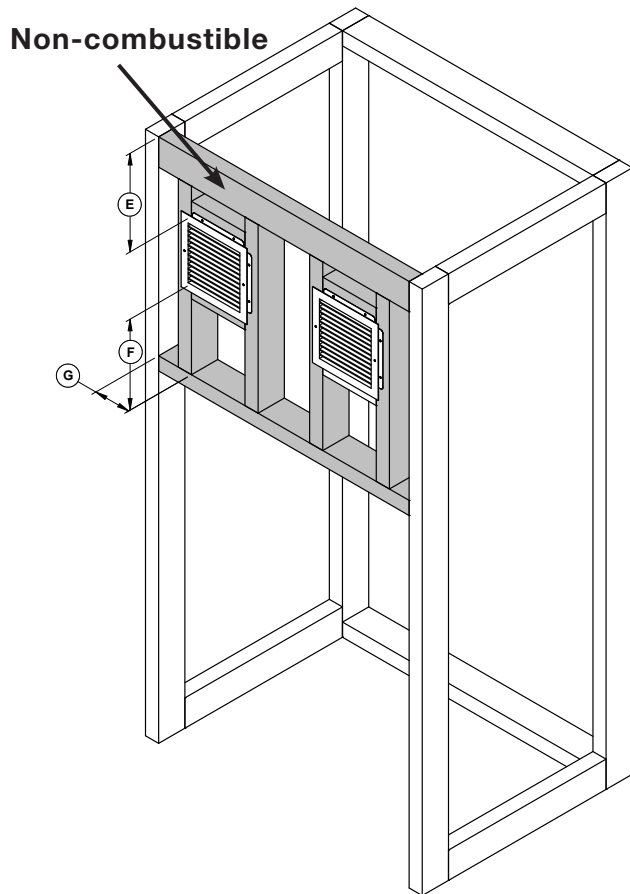

The framing dimensions are for reference only.

Framing touching the grills must be made from non-combustible materials (dark area). Finishing material covering the dark framing must be made from non-combustible materials. See facing section.

- E:** Minimum distance between the grill and the combustible ceiling (8" [203 mm])
- F:** Minimum distance below the grill to non-combustible stud (14" [355 mm])
- F:** Minimum distance between the grill and a non-combustible shelf (Not shown) (15" [381 mm])
- G:** Distance between the framing and the first stud (3" [76 mm])

4.4.3 Framing with Fresh Air Intake¹⁴

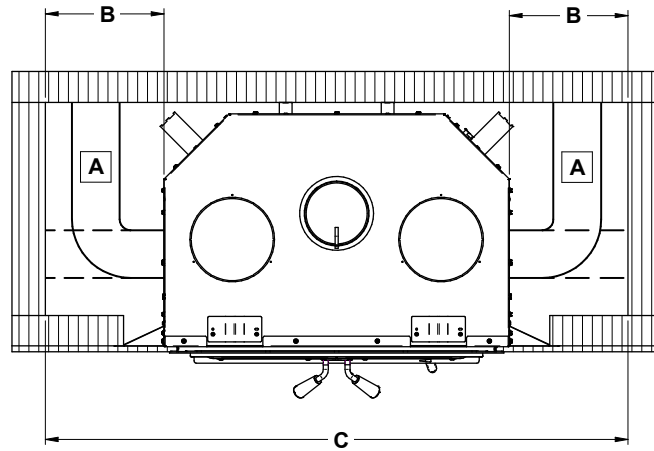

If a finishing material is installed inside the enclosure, its thickness must be added to the following measurements.

- A** : Fresh air intake duct¹⁵ (Fresh air intake can be installed on the right, left or underneath).
- B** : Distance between framing and side fireplace standoff 12" (305 mm)
- C** : Framing width (Installation with centered fireplace) 60 ¾" (1543 mm)

4.4.4 Framing with forced air kit¹⁶

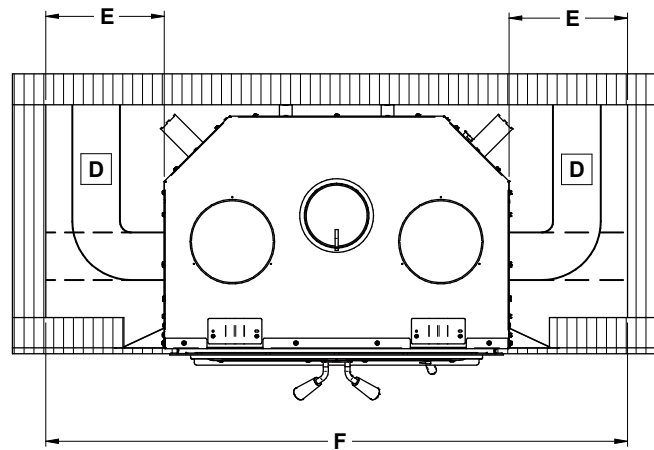

If a finishing material is installed inside the enclosure, its thickness must be added to the following measurements.

- D** : Forced air duct¹⁷ (Duct can be installed on the left [recommended] **or** on the right).
- E** : Distance between framing and side fireplace standoff 18" (457 mm)
- F** : Framing width (Installation with centered fireplace) 72 ¾" (1848 mm)

¹⁴ Framing dimensions are for reference only. These measurements are recommended to prevent the ducts from being inside the standoff or have too tight duct curves. Smaller dimensions can be used depending on the size and type of duct as well as the configuration of the installation.

¹⁵ HVAC duct, as per ULC S110 or UL 181, class 0 or class 1, must withstand temperatures up to 250°F.

¹⁶ Framing dimensions are for reference only. These measurements are recommended to prevent the ducts from being inside the standoff or have too tight duct curves. Smaller dimensions can be used depending on the size and type of duct as well as the configuration of the installation.

¹⁷ HVAC duct, as per ULC S110 or UL 181, class 0 or class 1, must withstand temperatures up to 250°F.

4.4.5 Framing with corner installation

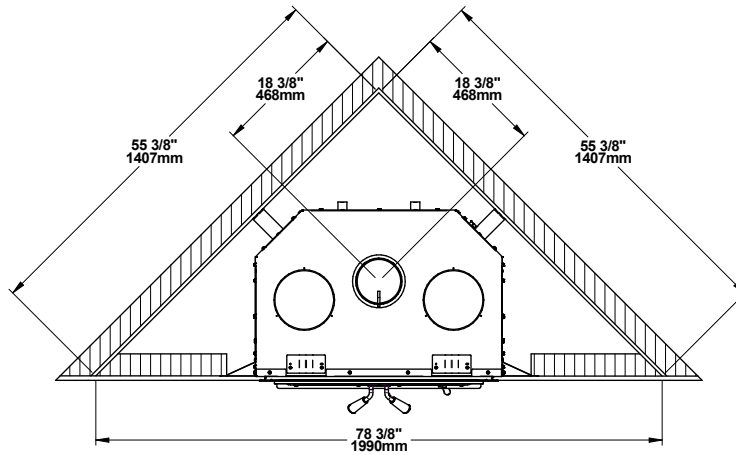

Framing configuration should be used as a reference only. If a finishing material is installed inside the enclosure, its thickness must be added to the following measurements. These values are minimum measurements and may need to be increased to allow the installation of the fresh air intake, the forced air kit or the type of finishing material used.

4.5 Hearth Extension Construction

WARNING: THE HEARTH EXTENSION IS TO BE INSTALLED ONLY AS ILLUSTRATED.

This fireplace can be installed directly on the floor or on a raised base, combustible or not. The installation can be done according to one of the following options :

OPTION	INSTALLATION TYPE	R VALUE REQUIRED	NON-COMBUSTIBLE FLOOR PROTECTION DEPTH
#1	On floor level	Yes (1.00)	16" (406 mm)
#2	Raised base of less than 4" (101 mm)	Yes (1.00)	16" (406 mm)
#3	Raised base of 4" (101 mm) or more	No	16" (406 mm)

4.5.1 Option #1 - Floor Level Installation

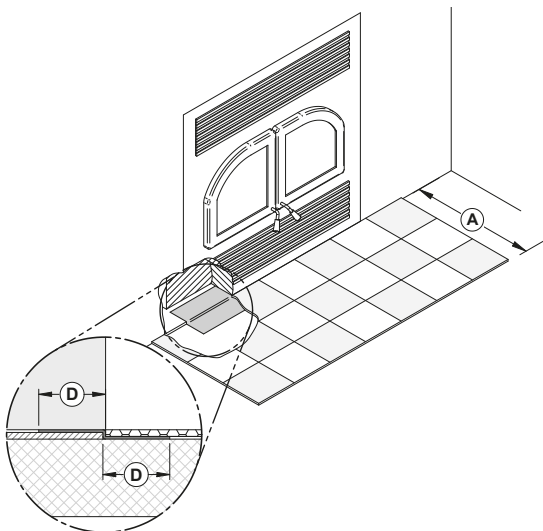

When the fireplace is installed directly on the floor, a non-combustible floor protection of at least 16" (406 mm) **(A)** with an R value of 1.00 must be installed in front of the fireplace. The joint between the floor protection and the fireplace must be protected over the entire width of the floor protection by a folded and continuous metal sheet **(D = min 2" [51 mm])** (not supplied).

A clearance of 80" (2032 mm) between the base of the fireplace and the ceiling must be respected.

The minimum floor height under the fireplace should match (or exceed) the height of non-combustible materials used for floor protection.

4.5.2 Option #2 - Raised Base Installation of Less Than 4" (101 mm)

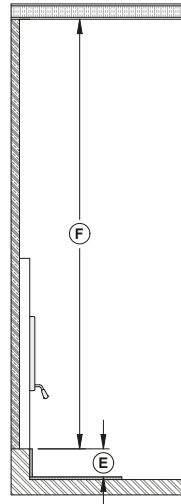
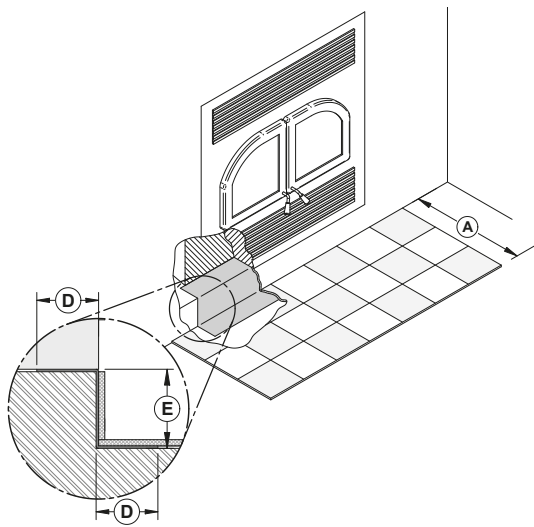

When the fireplace is installed on a raised base of less than 4" (101 mm) **(E)**, a non-combustible floor protection of at least 16" (406 mm) **(A)** with an R value of 1.00 must be installed in front of the fireplace.

The joint between the floor protection and the fireplace must be protected over the entire width of the floor protection by a folded and continuous metal sheet **(D = min 2" [51 mm])** (not supplied). It is recommended to make the sheet metal in one piece.

*A clearance of 80" (2032 mm) **(F)** between the base of the fireplace and the ceiling must be respected.*

ENGLISH

4.5.3 Option #3 - Raised Base Installation of 4" (101 mm) or More

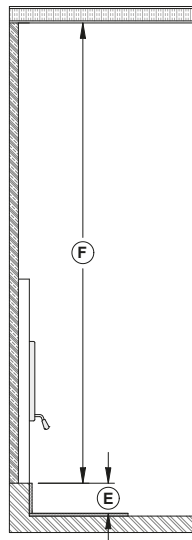
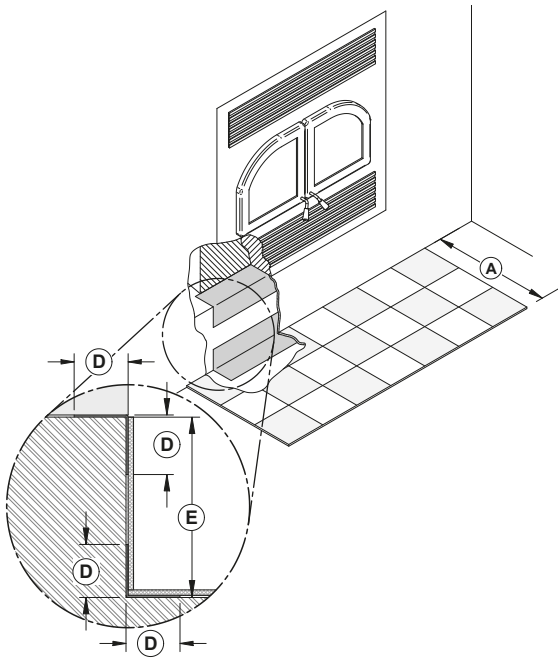

When the fireplace is installed on a raised base of 4" (101 mm) or more **(E)**, a non-combustible floor protection of at least 16" (406 mm) **(A)** with no R value, must be installed in front of the fireplace.

The upper and lower angle, for the full width of the floor protection, must be protected by 2" (51 mm) horizontally and vertically by a folded and continuous metal sheet **(D = 2" [51 mm])** (not supplied). The sheet metal does not have to cover the rest of the wall between the base of the fireplace and the floor.

*A clearance of 80" (2032 mm) **(F)** between the base of the fireplace and the ceiling must be respected.*

4.5.4 Floor Protection

OPTION	INSTALLATION TYPE	R VALUE REQUIRED	A	B	C
#1	On floor level	Yes (1.00)	16" (406 mm)	36 ¾" (933 mm)	8" (203 mm)
#2	Raised base of less than 4" (101 mm)	Yes (1.00)	16" (406 mm)	36 ¾" (933 mm)	8" (203 mm)
#3	Raised base of 4" (101 mm) or more	No	16" (406 mm)	36 ¾" (933 mm)	8" (203 mm)

ENGLISH

Regardless of the installation type, there must be at least 8" (203 mm) on each side of the fireplace door opening **(C)**.

Floor protection must be a continuous non-combustible surface such as ceramic, concrete board, brick or other equivalent material approved as floor protection. If the ceramic is used, it must be placed on a continuous non-combustible panel to prevent spills from being brought into contact with the floor through cracks or gaps in the ceramic slurry. Alternatives approved by the local building code may also be used.

Do not leave carpets under the floor protection.

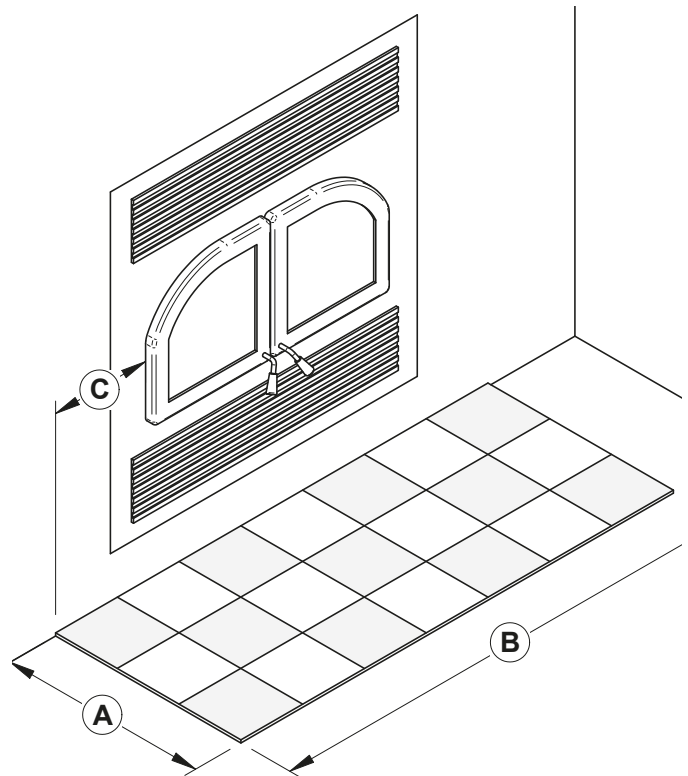

4.5.5 R Value

There are two ways to calculate the R-value of the floor protection. First, by adding the R-values of materials used, or by the conversion if the K factor and thickness of the floor protection are given.

To calculate the total R value from R values of the materials used, simply add the R-values of materials. If the result is equal to or greater than the R-value requirements, the combination is acceptable. R-values of some selected materials are shown below :

Table 3 : Thermal Characteristics of Common Floor Protection Materials¹⁸

MATERIAL	CONDUCTIVITY (K) PER INCH	RESISTANCE (R) PER INCH THICKNESS
Micore® 160	0.39	2.54
Micore® 300	0.49	2.06
Durock®	1.92	0.52
Hardibacker®	1.95	0.51
Hardibacker® 500	2.3	0.44
Wonderboard®	3.23	0.31
Cement mortar	5.00	0.2
Common brick	5.00	0.2
Face brick	9.00	0.11
Marble	14.3 – 20.00	0.07 – 0.05
Ceramic tile	12.5	0.008
Concrete	1.050	0.950
Mineral wool insulation	0.320	3.120
Limestone	6.5	0.153
Ceramic board (Fibremax)	0.450	2.2
Horizontal still air ¹⁹ (1/8" [3 mm] thick)	0.135	0.920 ¹⁹

Example:

Required floor protection R of 1.00. Proposed materials: four inches of brick and one inch of Durock® board.

Four inches of brick (R = 4 x 0,2 = 0,8) plus 1 inch of Durock® (R = 1 x 0.52 = 0.52).
 $0.8 + 0.52 = 1.32.$

This R value is larger than the required 1.00 and is therefore acceptable.

In the case of a known K and thickness of alternative materials to be used in combination, convert all K values to R by dividing the thickness of each material by its K value. Add R values of the proposed materials as shown in the previous example.

<p>Common brick K value = 5 Thickness = 4" $R \text{ value} = \text{Thickness}/K = 4/5 = 0.8$</p>	<p>Durock K value = 1.92 Thickness = 1" $R \text{ value} = \text{Thickness}/K = 1/1.92 = 0.52$</p>
<p>Total R value = .8 + 0.52 = 1.32</p>	

¹⁸ Information as reported by manufacturers and other resources

¹⁹ Horizontal still air can't be «stack» to accumulate R-values; each layer must be separated with another non-combustible material.

4.6 Facing

Non-combustible finishing materials such as brick or ceramic can be glued to the facade of the fireplace. Do not put a seal between the faceplate and the finishing material to facilitate the removal of the faceplate if necessary.

ENGLISH

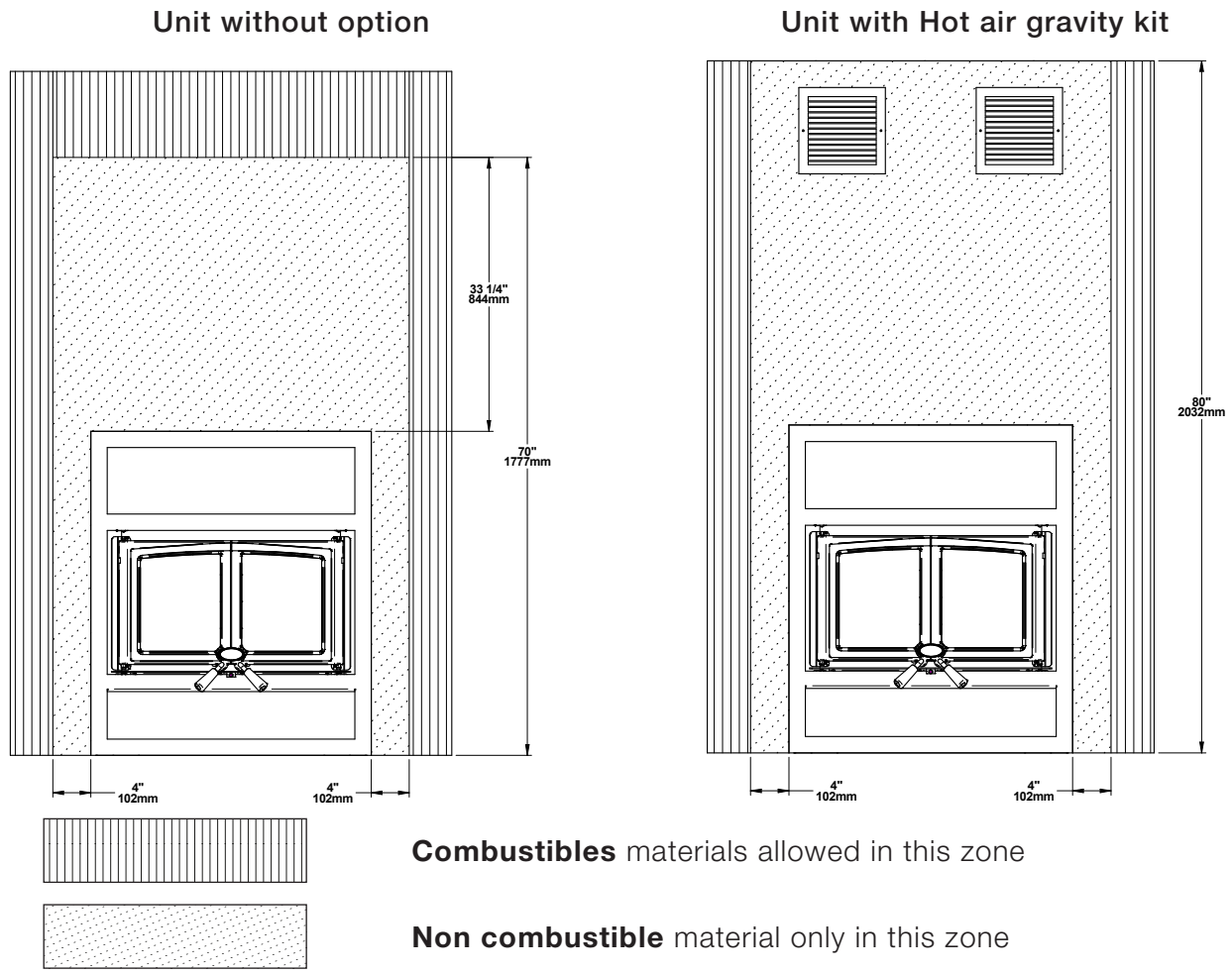

4.7 Shelf Installation

A **non-combustible** shelf with a depth of 6" (152 mm) to 12" (305 mm) can be installed at least 48" (1219 mm) from the base of the fireplace.

In order to install a **combustible** shelf, a metal **heat shield** must be installed 5" (127 mm) below the combustible shelf (**C**). The depth (**D**) of the heat shield is equal to the depth of the combustible shelf minus one inch. A combustible shelf with a depth of 6" (152 mm) (**A**) must be installed at least 48" (1219 mm) from the base of the fireplace (**B**). Different shelf sizes are listed in the following table.

POSITIONING AND DEPTH OF THE SHELF	
B	A
48" (1,21 m)	6" (152 mm)
50" (1,27 m)	8" (203 mm)
52" (1,32 m)	10" (254 mm)
54" (1,37 m)	12" (305 mm)

For a shelf dimension that does not appear in the table, add 42" (1066 mm) to the depth of the shelf to find the safe position of the shelf. The height (**E**) should always be 80" (2032 mm) from the base of the fireplace.

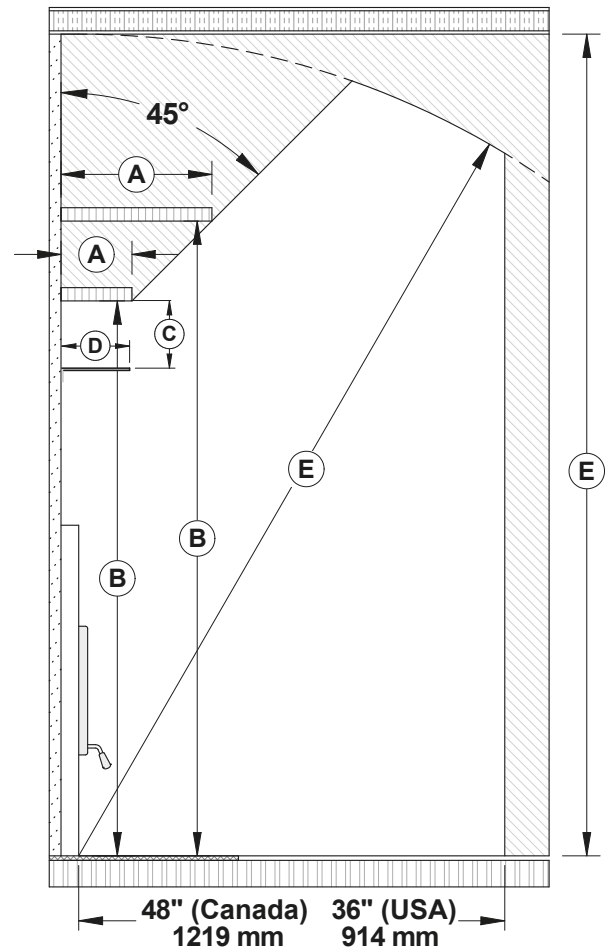

5. Chimney Installation

The chimney manufacturer's installation manual takes precedence over the following installation instructions. To ensure a safe installation, please refer to it. Some non-illustrated parts may be required.

5.1 General Advices

- This wood burning fireplace has optimum performance and efficiency when connected to a **chimney** with a **6" (150 mm) diameter flue**, only the chimneys listed in the "[Table 1 : Approved Chimneys](#)", [page 19](#) can be used.
- To insure a good draft, it is recommended to have a length of 18" (457 mm) from the top of the unit to the first offset. However, starting using a 30° or 45° (Canada Only) elbow is also approved.
- **A CHIMNEY VENTING A FIREPLACE SHALL NOT VENT ANY OTHER APPLIANCE.**
- The **minimum height of the chimney** system is **15 feet (4.6 m)** from the base of the appliance to the chimney cap. If only the minimum height of the chimney system is installed, the operating conditions must be optimal (interior chimney, minimum height of 18" (457 mm) before any deviation, etc.).
- The **chimney** must have **at least one support**. The maximum chimney length that should be supported by the fireplace is 9 feet (2.75 m) for 2" (51 mm) Solid Pack chimney and 12 feet (3.7 m) for 1" (25,4 mm) Solid Pack chimney.
- The chimney must extend at least 3 ft. (92 cm) above its point of contact with the roof and at least 2 ft. (61 cm) higher than any wall, roof or building within 10 ft. (3.1 m) of it.
- **WARNING : IF THE CHIMNEY IS INSTALLED IN A CHASE, IT MUST EXCEED THE TOP OF IT BY AT LEAST 3 FEET (92 CM) IF IT'S MADE OF COMBUSTIBLE MATERIALS OR AT LEAST 1.5 FEET (46 CM) WHEN IT IS MADE OF NON-COMBUSTIBLE MATERIALS.**

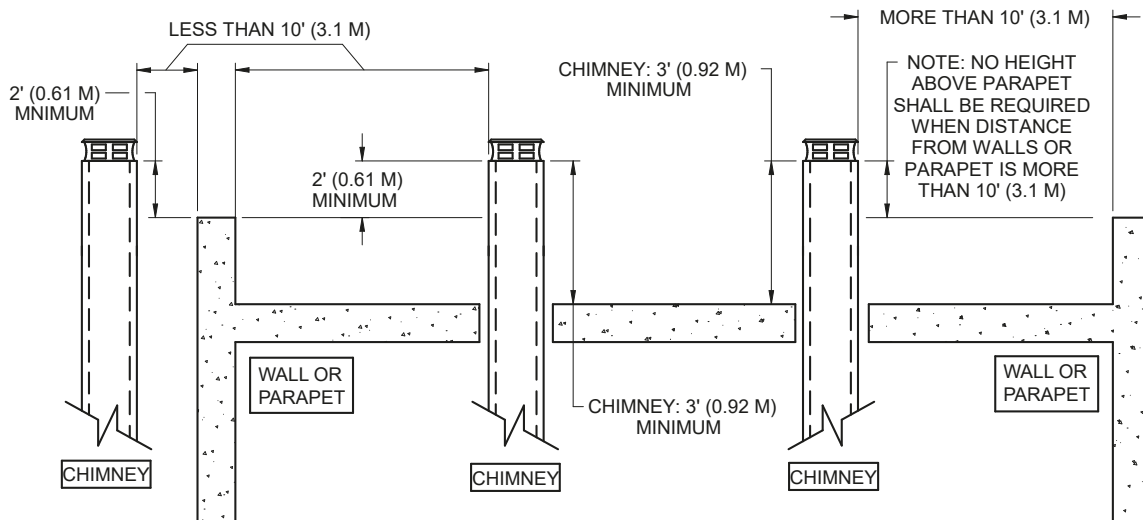
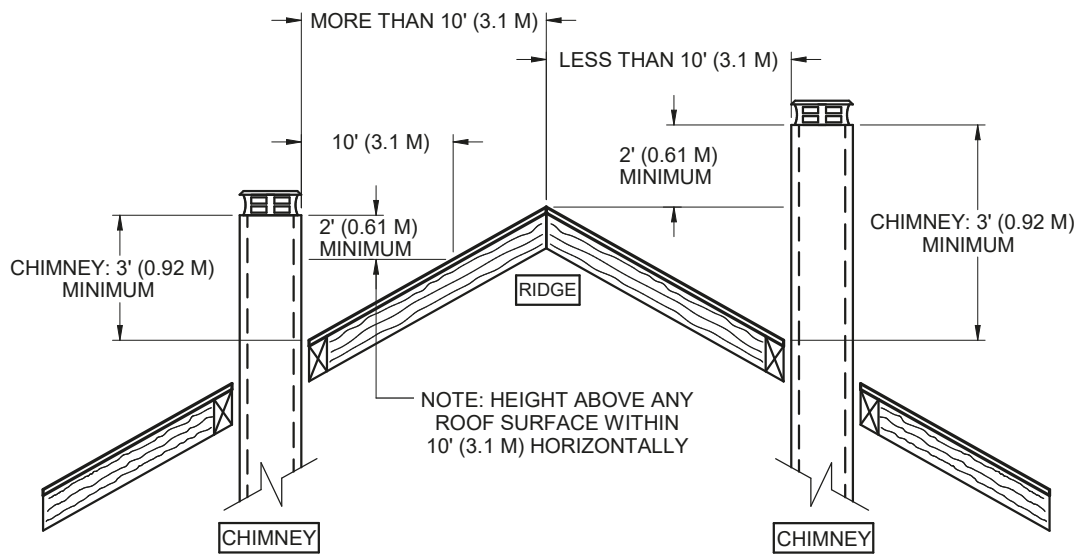

- Avoid deviations as much as possible, especially the sharp ones. Each deviation adds restriction to the system and can lead to draft problems.
- If the chimney extends higher than 5 ft. (1.5 m) above its point of contact with the roof, it must be secured using a roof brace.
- A rain cap must be installed on top of the chimney.

- For installations where more than one chimney is located in the same non-chase or within the same area, their terminations must be separated by at least 16" (406 mm) horizontally, and 18" (457 mm) vertically. This separation is to prevent smoke migrating from one chimney to another.

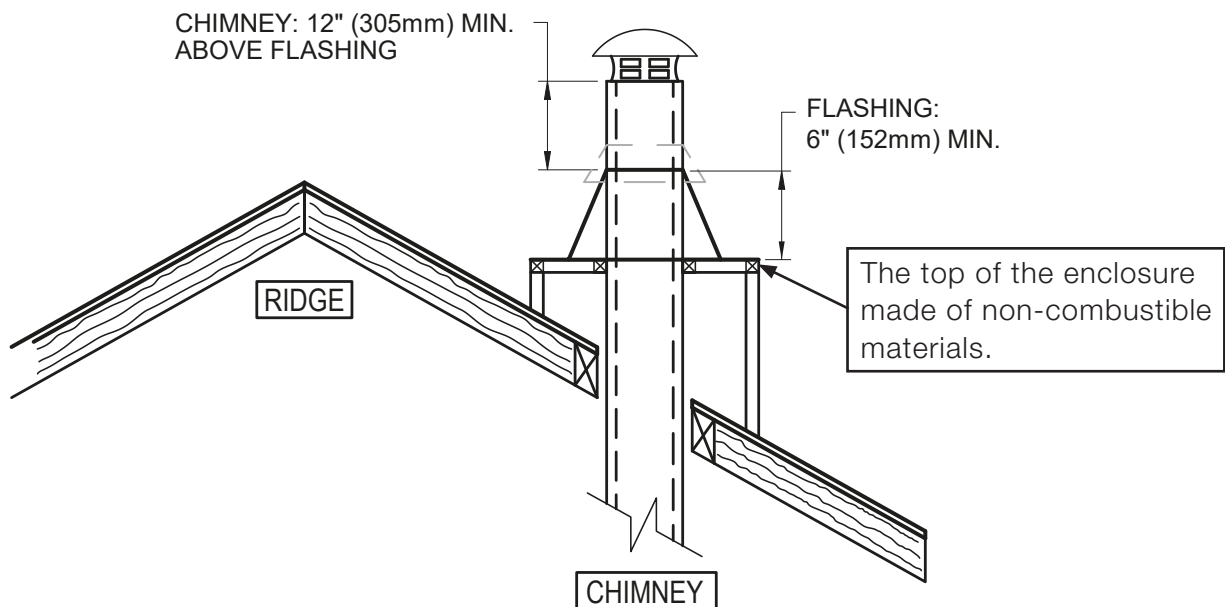
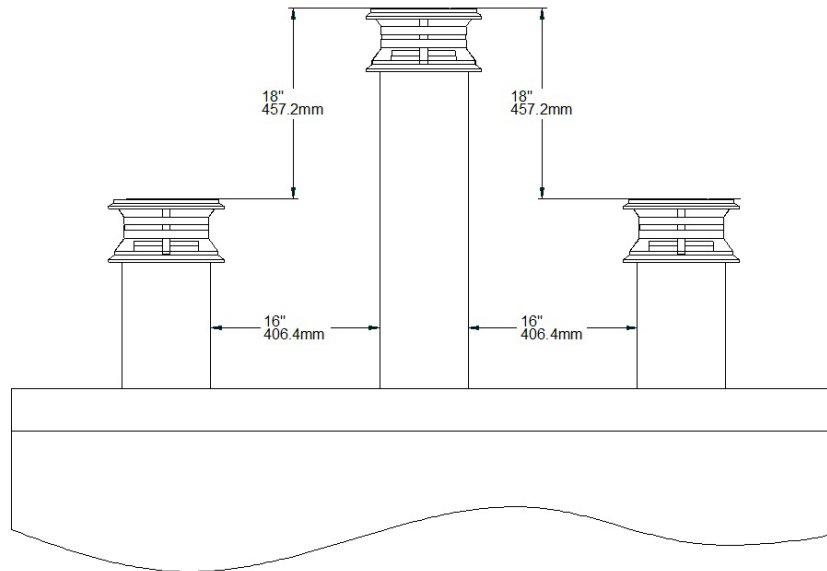

Note: The chimney chase on the roof must be the same size as the flashing.

- **WARNING: IF THE CHIMNEY IS INSTALLED IN AN ENCLOSURE ABOVE THE ROOF, IT MUST EXCEED THE TOP OF THE FLASHING CONE BY AT LEAST 12 INCHES (30 CM). THE FLASHING MUST HAVE A MINIMUM HEIGHT OF 6 INCHES (15.25 CM). THE TOP OF THE ENCLOSURE MUST BE MADE OF NON-COMBUSTIBLE MATERIALS.**

- A clearance of 2" (51 mm) between the chimney and any combustible material is required. This space must remain free, without insulation or other combustible material. The parts of the chimney that pass into inhabited spaces must be enclosed in an enclosure.
- In all cases, the chimney must start with a 6" (15,25 cm) diameter anchor plate attached to the fireplace.
- If the male anchor plate nozzle exceeds 2" (51 mm) in length (**A**), it must be cut above the lifting hooks welded inside the flue outlet so that it is sitting perfectly on the top of the fireplace.

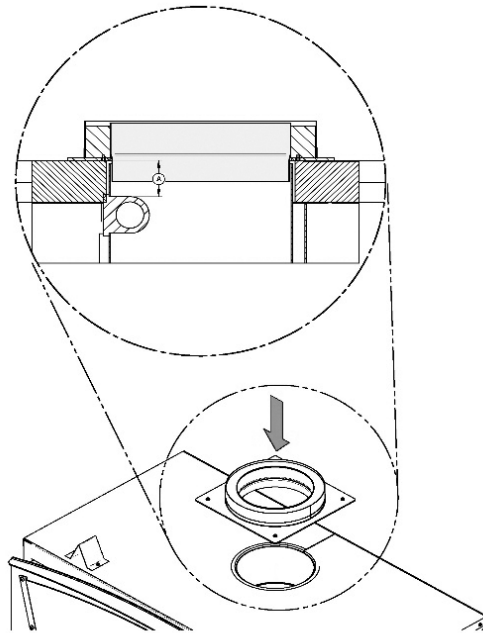

5.2 Ceiling Supported Installation

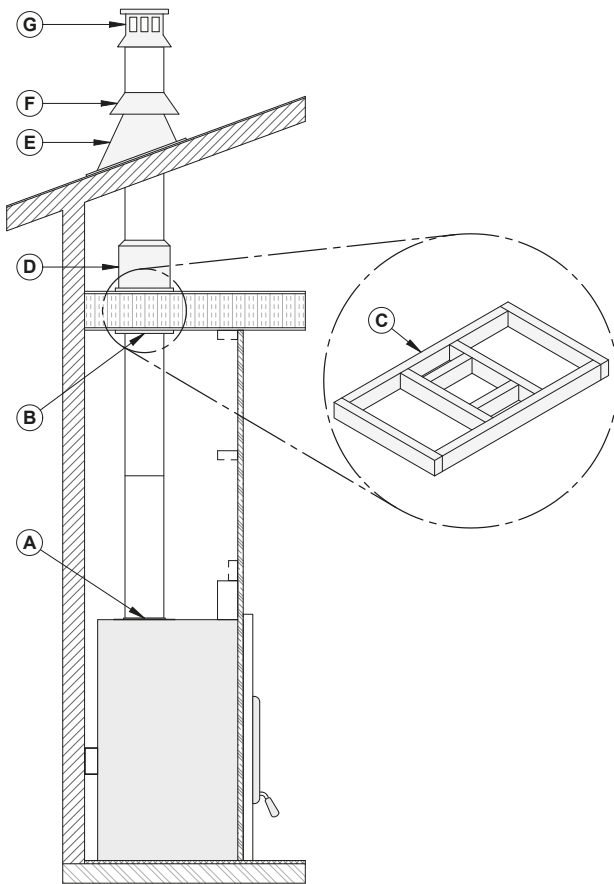

- A : Anchor plate*
- B: Ceiling support*
- C: Framing opening*
- D: Attic insulation shield*
- E: Roof flashing*
- F: Storm collar*
- G: Chimney cap*

1. Cut and frame square openings **(C)** in the ceiling, floor and roof where the chimney will pass. A 2" (51 mm) clearance must be maintained between the chimney and any combustible materials. The 2" (51 mm) space must remain empty, without insulation or any other combustible material. The size of the floor and ceiling holes must be in accordance with the chimney manufacturer's instructions.
2. From underneath the ceiling, install a ceiling support **(B)** in each floor where the chimney will pass. In the attic, install an attic radiation shield from above **(D)**.
3. Install an anchor plate **(A)** and a first chimney section on the fireplace. Install the number of chimney sections needed, making sure to lock each section in place.
4. When the desired height of the chimney is reached, install a roof support (not shown).
5. Put the roof flashing **(E)** in place and seal the joint between the roof and the flashing with roof sealant. For sloping roofs, place the flashing under the upper shingles and on top of the lower shingles. Nail the flashing to the roof, using roofing nails.

When a ventilated roof flashing is installed, precautions are to be taken not to caulk or seal the ventilating openings.

6. Place the storm collar **(F)** on the roof flashing and tighten it with the bolt. Seal the joint between the storm collar and the chimney, using silicone sealant.
7. Install the chimney cap **(G)**.

5.3 Offset Installation

1. Follow the instructions for a ceiling supported installation until the first elbow.
2. Install and turn the elbow in the right direction. Attach to the chimney using three ½" (13 mm) metal screws.
3. Install the appropriate number of chimney sections to obtain the necessary deviation. Secure the chimney sections together with three ½" (13 mm) screws. If the offset section has two or more chimney sections, a bracket must be installed. If the chimney go through a wall, install a wall thimble.
4. Install another elbow to bring the chimney back in a vertical position.
5. Continue the installation following the instructions of the ceiling supported installation.

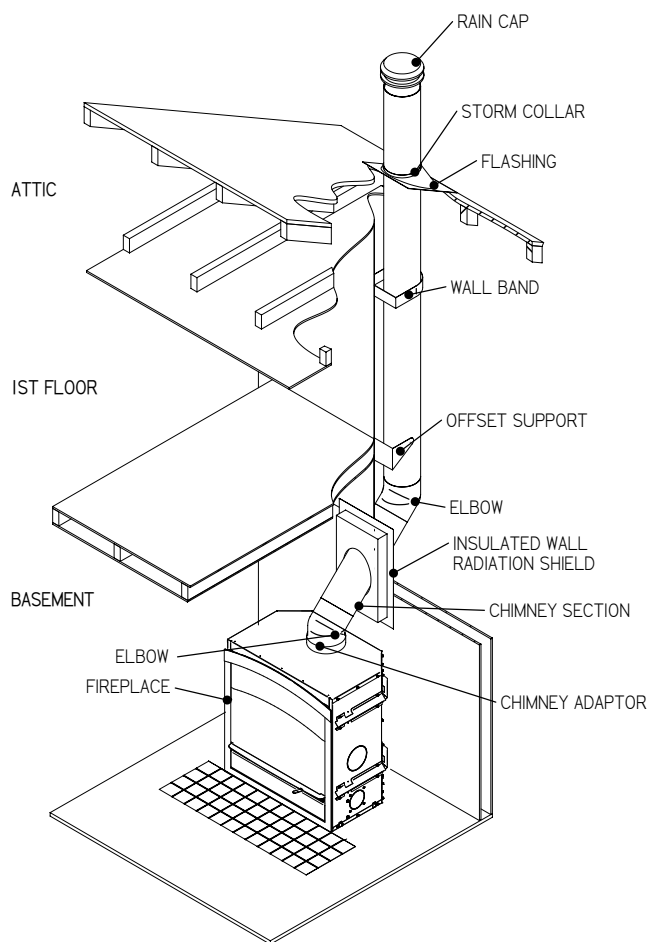

ENGLISH

Table 4 : Minimum system height when using elbows

Chimney model	Please consult the specification manual for your fireplace
Vertical Installation	15 ft (4,6 m)
Two (2) elbows	15 ft (4,6 m)
Four (4) elbows	17 ft (5,2 m)

- A maximum of two deviations are permitted in a chimney. A maximum of 6 ft (1,82 m) of unsupported chimney between elbows is permitted. If it is longer than 6 ft (1,82 m), it will need to be supported every 6 ft (1,82 m).

5.4 Masonry Chimney Installation

The masonry chimney must meet the minimum requirements of the local building code or equivalent for a safe installation. Contact a building inspector to learn about the requirements in the area.

Before starting the installation, the masonry chimney should be inspected for cracks, crumbling mortar, creosote layers, obstructions or other signs of deterioration. If signs of deterioration are noted, the chimney should be repaired and cleaned before installation.

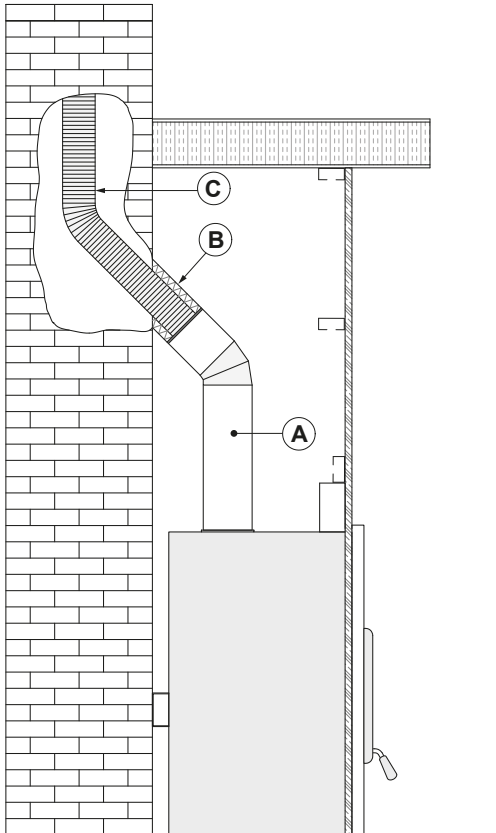

1. Position the fireplace in its location. Temporarily install the elbow or chimney section **(A)** on the top of the fireplace and, using a level, mark with an oval the location where the flue liner will enter the masonry chimney.
2. Mark where the flue will pass through the masonry chimney. Drill a hole in the masonry chimney to insert an insulated liner adapter **(B)**.
3. Lower the liner **(C)** into the chimney to the level of the hole.
4. Slide an insulated 45° or 30° liner adapter and connect it to the liner.
5. Seal the opening around the liner with high temperature refractory cement.
6. Then, follow the chimney manufacturer's instructions to connect the extended liner section to the special chimney connector.

The liner must extend at least 12" (30 cm) above the masonry chimney.

5.5 Factory-Built Metal Chimneys in Mobile Homes

For use in a mobile home, this fireplace is to be connected to a 6" (15,25 cm) factory built chimney pipe conforming to ULC-S629 standards for 650°C Factory-built chimney. The total length of the flue system should be at least 12 feet (3,65 m) including elbows, from the top of the fireplace.

To maintain an effective vapour barrier, insulation and waterproof at the chimney and outside flue pipe, a roof flashing must be installed and sealed with silicone adhesive.

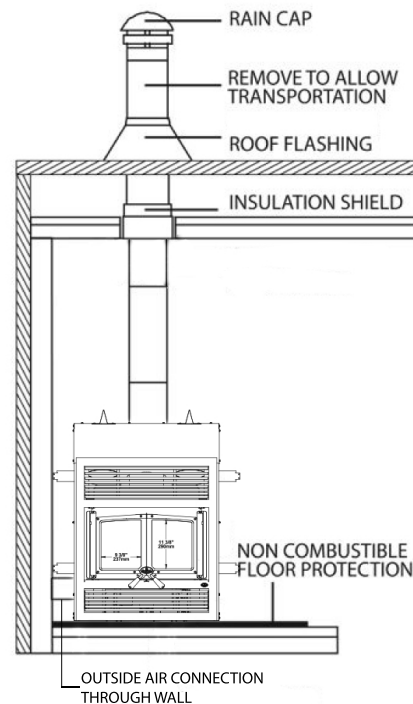

5.6 Angled Wall Pass-Thru Installation

When passing through a combustible wall with the chimney at a 30° or 45° angle (Canada only), an angled wall pass-thru must be installed. Follow the chimney manufacturer's installation instructions.

In cold climate locations, it is recommended to use the insulated wall pass-thru to maintain the home's thermal barrier.

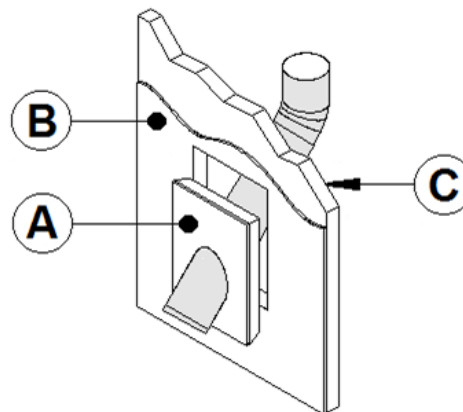

A	Wall pass-thru
B	Interior wall
C	Exterior wall

5.7 Chimney Support Installation

5.7.1 Roof Support

The universal roof support can be used on:

- a roof to support the chimney;
- a floor, ceiling, or roof over an offset to support the chimney or;
- as additional support.

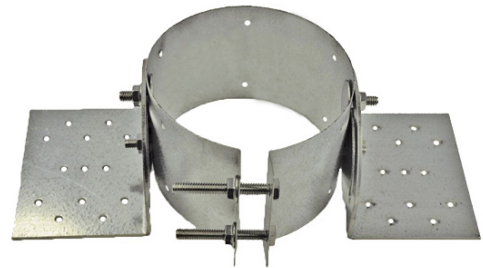

Always follow the manufacturer's instructions for the maximum chimney height that can be supported by the support.

5.7.2 Offset Support

This support is used above a chimney offset. When the offset of the chimney pass through a wall, this support can be installed on the wall to support the chimney.



5.7.3 Offset chimney installation for a ceiling of 96 inches (2,44 m) and less

It is permitted to offset the chimney when installing provided that the following measures are always respected. For a **left or right deviation (A)** there must always be a distance of **11" (27,94 cm)** between the chimney and combustible materials. For a **forward deviation (C)** there must always be a distance of **4 3/4" (12,07 cm)** between chimney and combustible material and **rear deflection (B)**, there should be a 2" (51 mm) distance between the chimney and combustible materials. It is permitted to offset the chimney when installing the two elbows directly on the anchor plate.

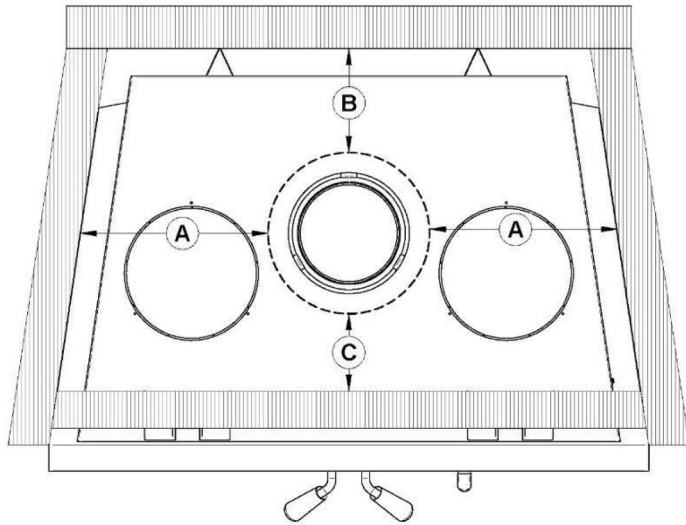

For example, for the next installation, the chimney cannot be closer to the combustible materials than the **value (A)**. Therefore, the enclosure should be 11 inches (27,94 cm) from the chimney.

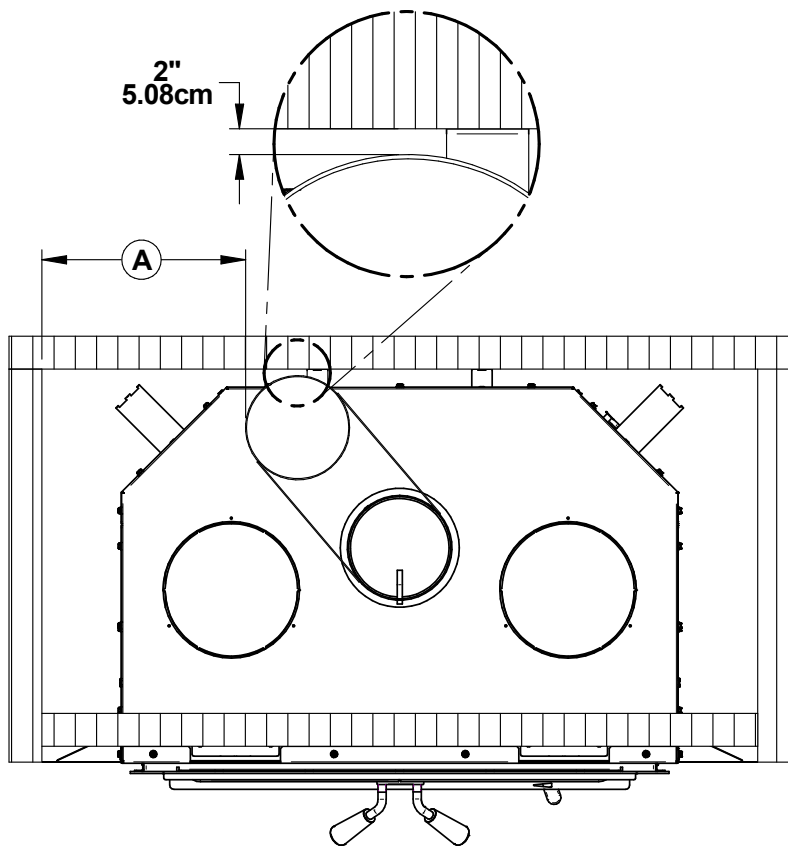
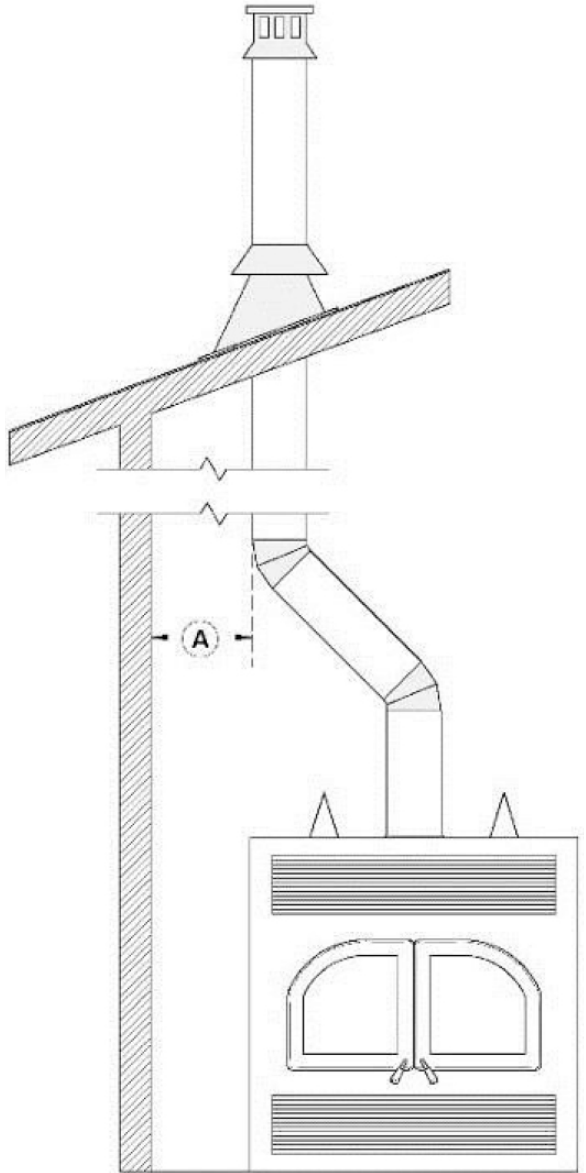

5.7.4 Offset chimney installation for a ceiling of 96 inches (2,44 m) or more

It is permitted to offset the chimney when installing provided that the distance between the floor and the ceiling is 96 inches (2,44 m) or more. The offset towards the rear wall can be done 2" (51 mm) between the chimney and the rear wall. It is permitted to offset the chimney when installing the two elbows directly on the anchor plate.

ENGLISH

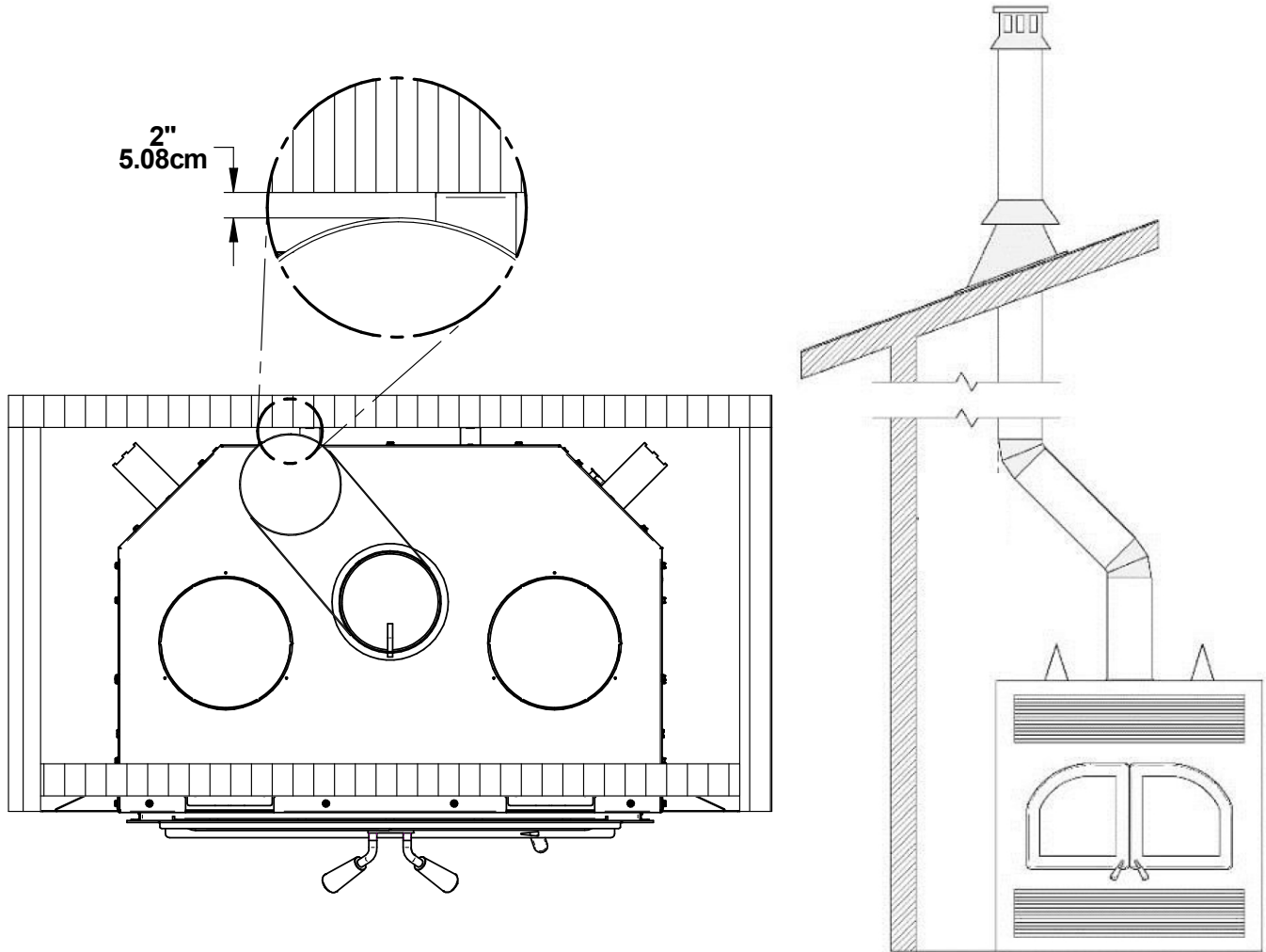

6. INSTALLATION OF OPTIONS ON YOUR PRODUCT

6.1 Faceplate and Louvers installation

A faceplate must be installed on this fireplace.

See the faceplate installation manual for more details.

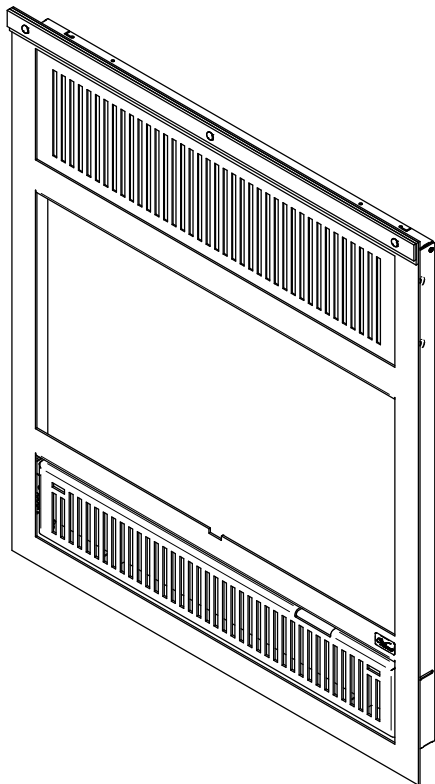

URBAN STYLE FACEPLATE LOUVERS

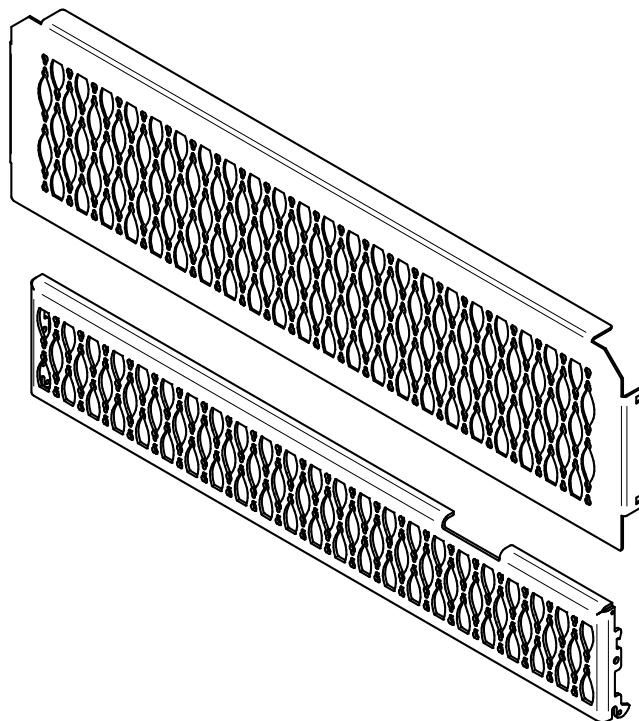

CLASSIC STYLE FACEPLATE LOUVERS

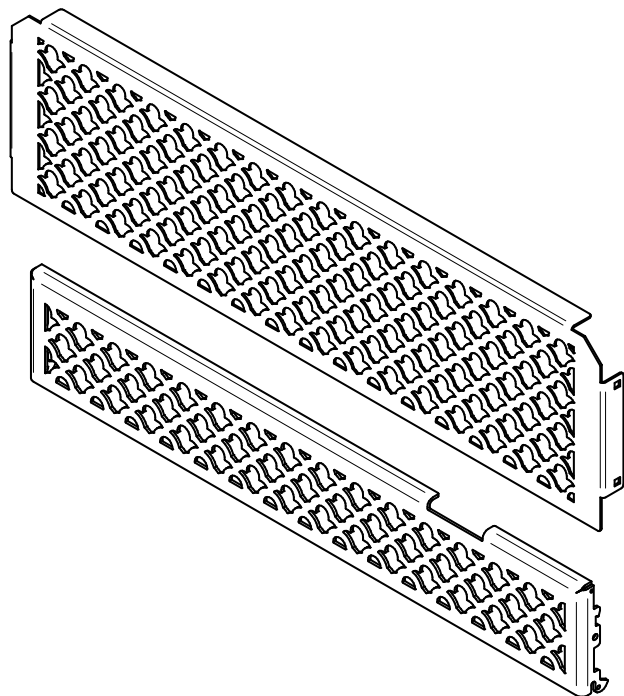

ARABESQUE STYLE FACEPLATE LOUVERS

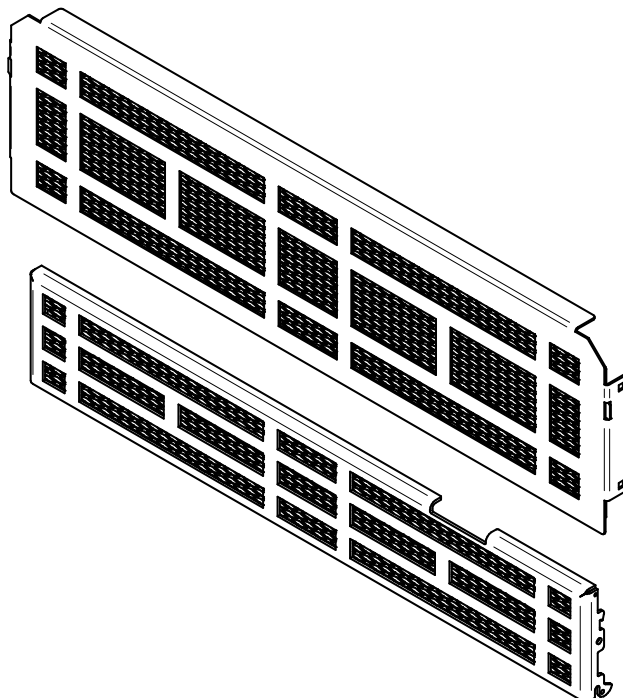

MISSION STYLE FACEPLATE LOUVERS

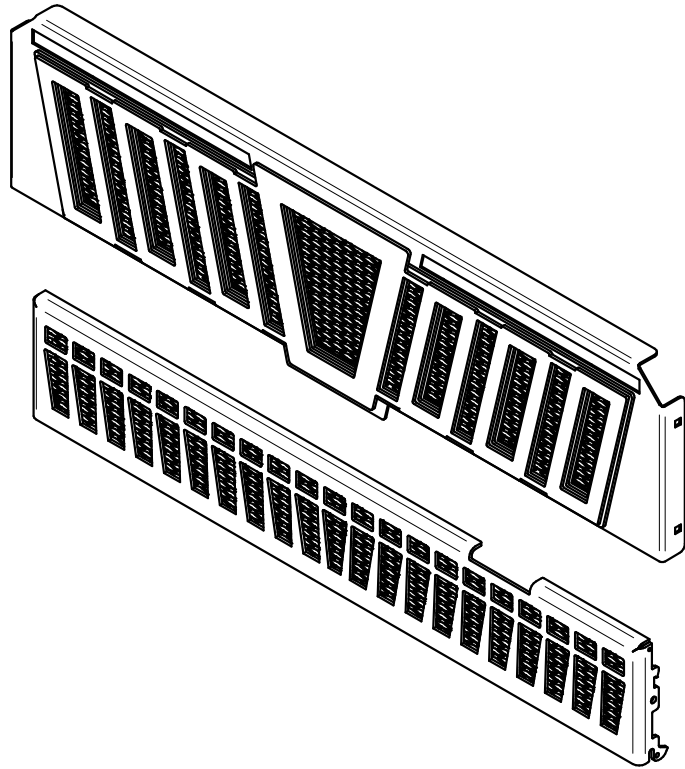

CROWN STYLE FACEPLATE LOUVERS

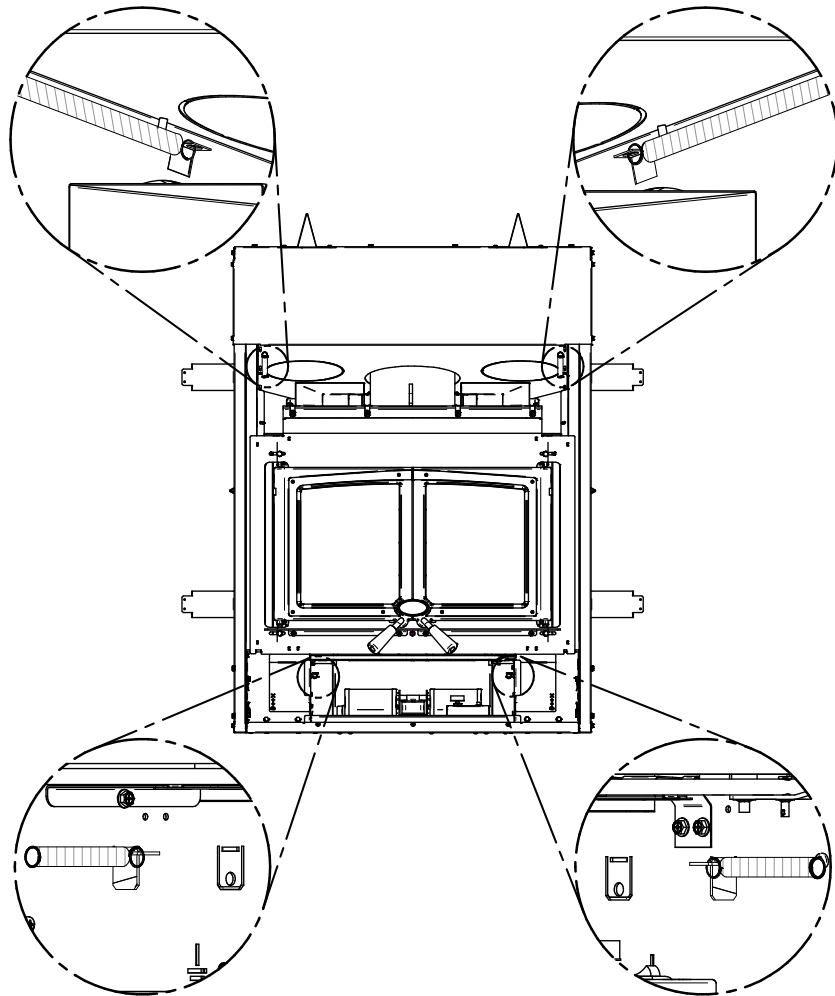

SPRING INSTALLATION (provided with the product manual kit)

6.2 Optional Fresh Air Kit Intake Installation

Follow the instructions below for connecting the fireplace to a fresh air intake:

- The insulated flexible pipe **(D)** should be of sufficient length (at least 10') and of a configuration to prevent condensation.
- The outside wall register **(E)** must not be installed:
 - More than 50% of the total height of the chimney;
 - At more than 10' (3 m) above the base of the fireplace;
 - More than 3' (0.9 m) below the base of the fireplace.
- The fresh air must come from outside the house. The air intake should not take air in the attic, basement or garage.
- The duct and the air intake can be installed above or below the floor level.
- The air intake should be installed high enough not to be obstructed by snow. It should be protected from the wind, away from automobile exhaust, a gas meter or other air inlets or outlets.

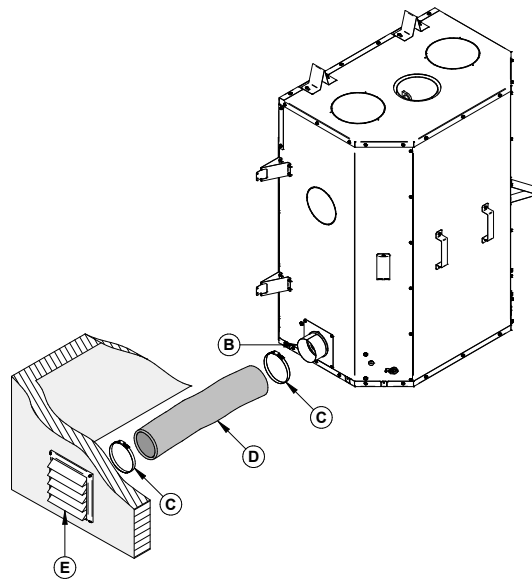

ENGLISH

The following items are included with the fireplace:

- One (1) 4" (76 mm) adapter **(B)**;
- One (1) air intake plate;
- Four (4) screws.

The following items are not included:

- The outside wall register **(E)**;
- The two (2) adjustable collars **(C)**;
- Insulated duct length 4" (76 mm) **(D)**. (Duct must be HVAC type and must comply with ULCS110 or UL 181, Class 0 or Class 1 and must withstand temperatures up to 250° F).

Note: Only remove the knockout that will be used to connect the fresh air intake assembly.

The fresh air intake can be installed in two different locations on the fireplace. On the right side **(1)** of the fireplace (the most common) or on the left side.

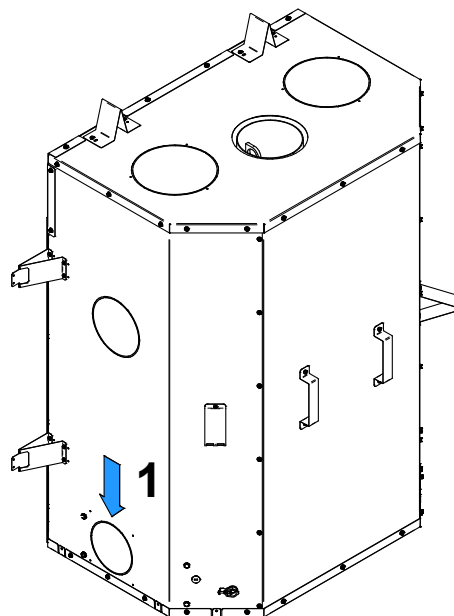

Installation



It is strongly recommended to wear gloves to complete the installation.

1. To use the air intake on the right side, remove the knockout by cutting the micro-joints. Cut and remove the insulation and the other knockout inside the fireplace **(1)**.
2. Install the adapter included in the fireplace **(2)** and align the notch of the adapter **(T)** with the one on the connection plate **(A)**. Turn the adapter clockwise.
3. Secure the connection plate **(A)** with four screws **(B)** using a star screwdriver **(3)**.

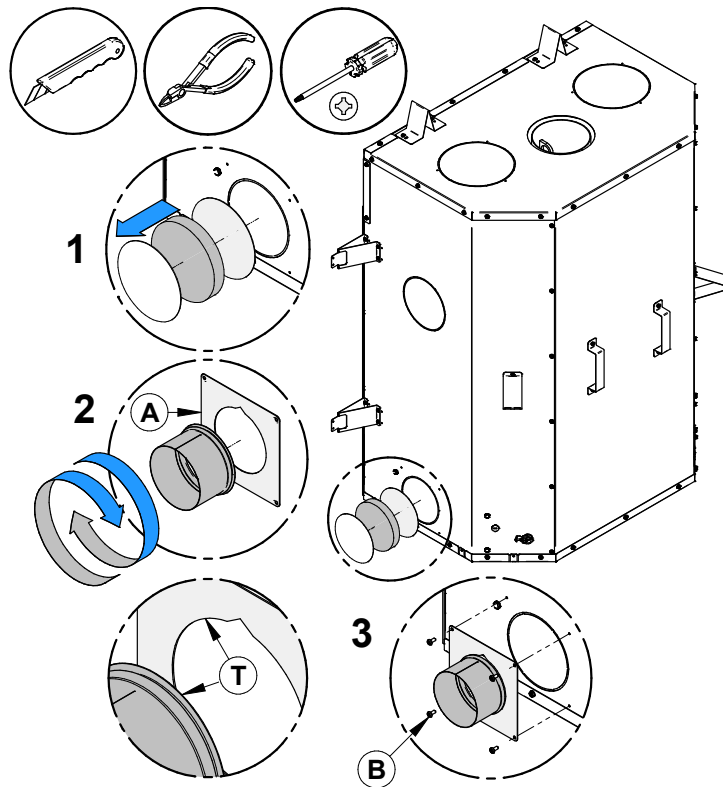

Fresh air intake on the right side

4. Adjust the fold of the two closest clips with a flathead screwdriver, just enough to slide a 1/8" (3,175 mm) plate underneath.

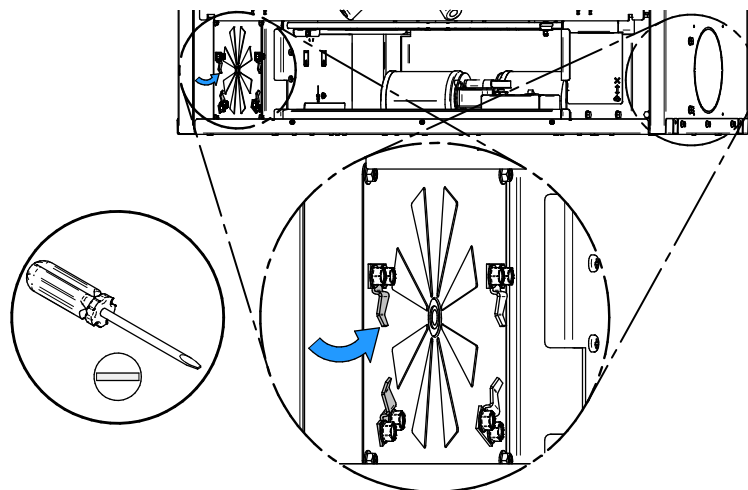

5. Install the damper (A) supplied with the product, with the hardware (B) provided in the manual kit.

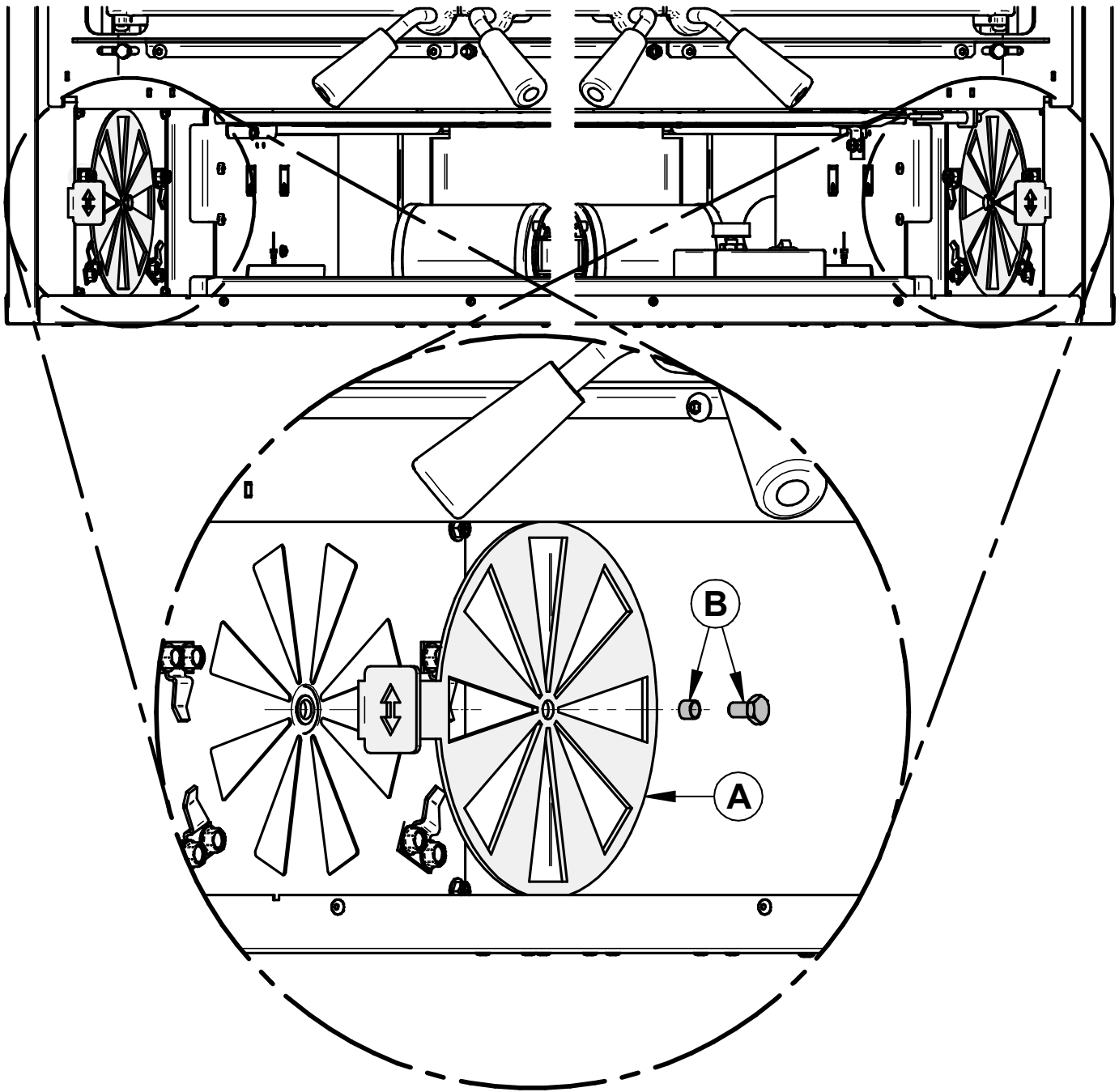

- Install the flexible duct **(D)** on the fresh-air inlet adapter **(B)** using one hose clamp **(C)**. Fix the other end to the outer wall register **(E)** using the second hose clamp **(C)**. The outer wall register **(E)** must be installed outside the house.

To properly install the flexible duct, gently remove the insulation and plastic wrap to expose the duct. Fix the duct using clamps. Stick aluminum tape around the joint between the duct and adapter to make the connection airtight. Carefully replace the insulation and plastic wrap on the duct. Secure the plastic with aluminum tape.

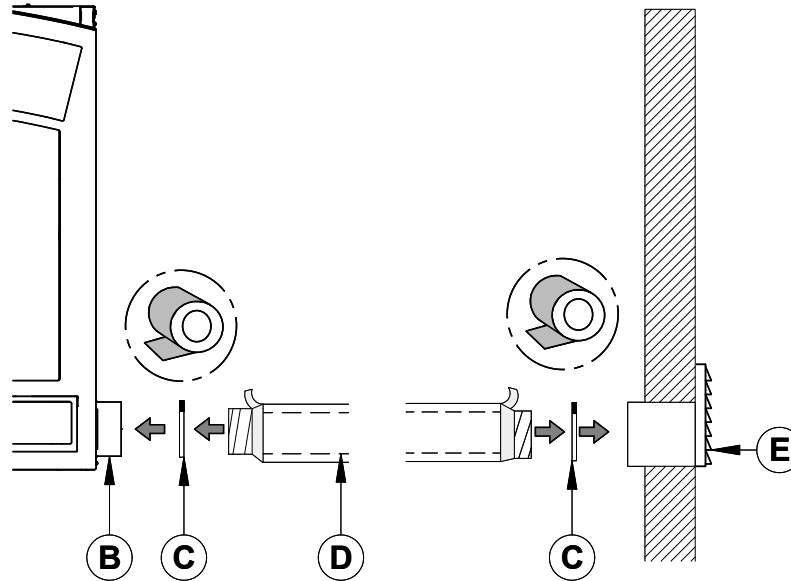

- To complete the installation, make a hole of $\frac{1}{4}$ " to $\frac{1}{2}$ " (6 mm to 13 mm) bigger than the duct diameter on the outside wall of the house at the chosen location. From outside, place the outside wall register in the hole (open side down) and fasten the register to the wall, with screws.

Use the required length for the installation while respecting the maximum length of 30' (9 m). To avoid condensation, it is recommended to use an insulated duct long enough and containing a «P-Trap» loop. This configuration can be done inside the chase, but must at all times maintain clearances to combustibles.

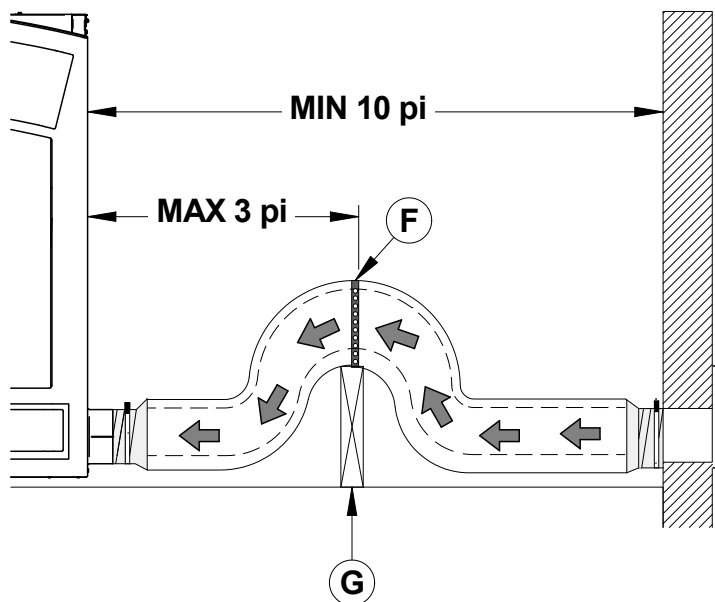

It is mandatory to install a mechanical shutter, right or left side depending on the installation of the air intake, that closes the outside air inlet when the fireplace is not in use.

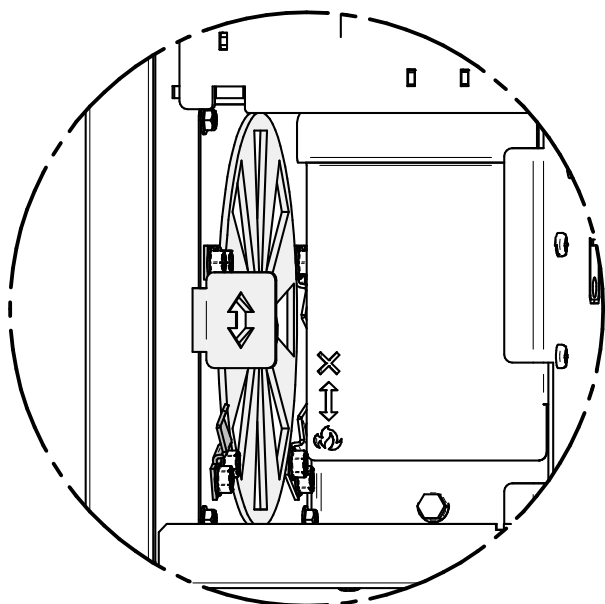

Closed hatch

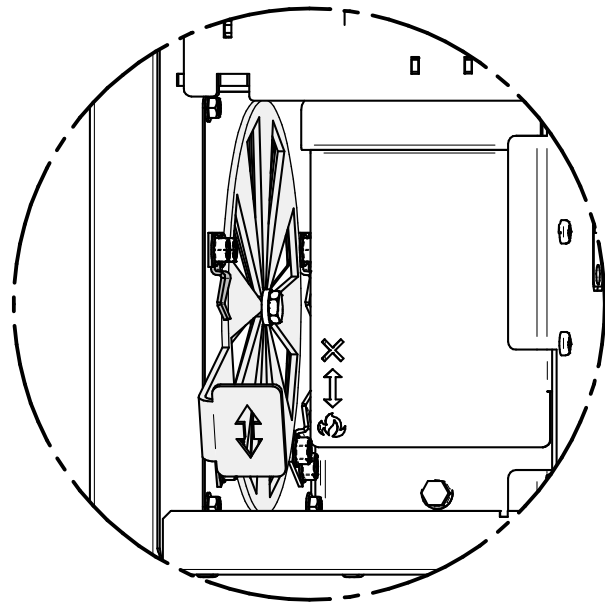

Opened hatch

6.3 Optional Traditional Gravity Hot Air Distribution Kit Installation

The kit includes:

- Two hot air outlets (grilles **(A)** and frames **(B)**);
- Two 90° elbows **(C)**;
- Six steel brackets **(D)** with six fastening screws **(E)** and twelve self-tapping screws **(F)**

Parts not included in the kit:

- Two 8" rigid ducting **(G)**, 26 ga, galvanized steel.

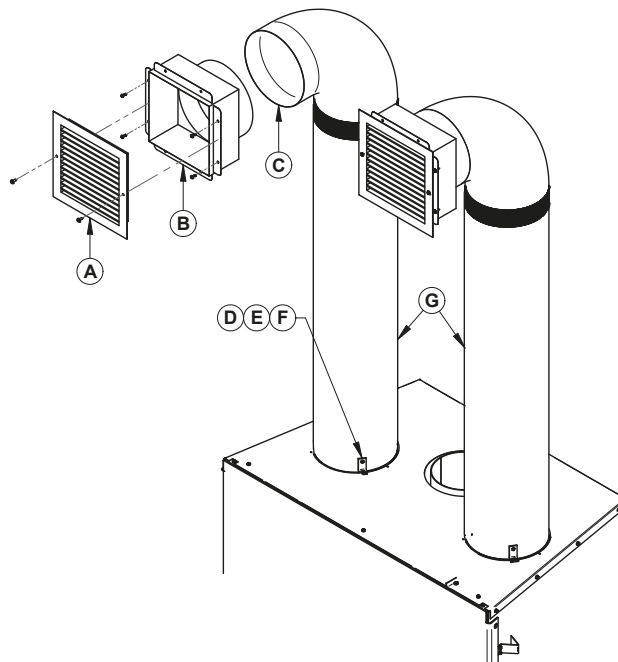

Dimensions of hot air outlet frame with elbow

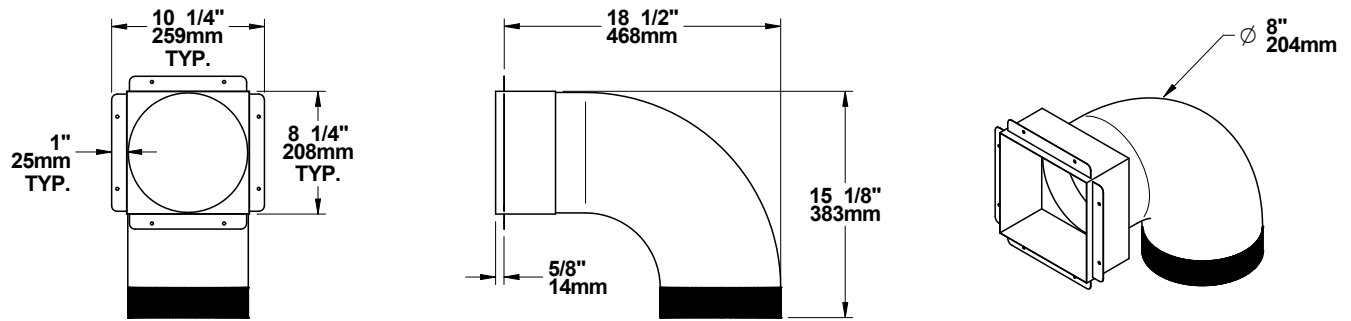

ENGLISH

Dimensions of hot air outlet decorative grille with elbow

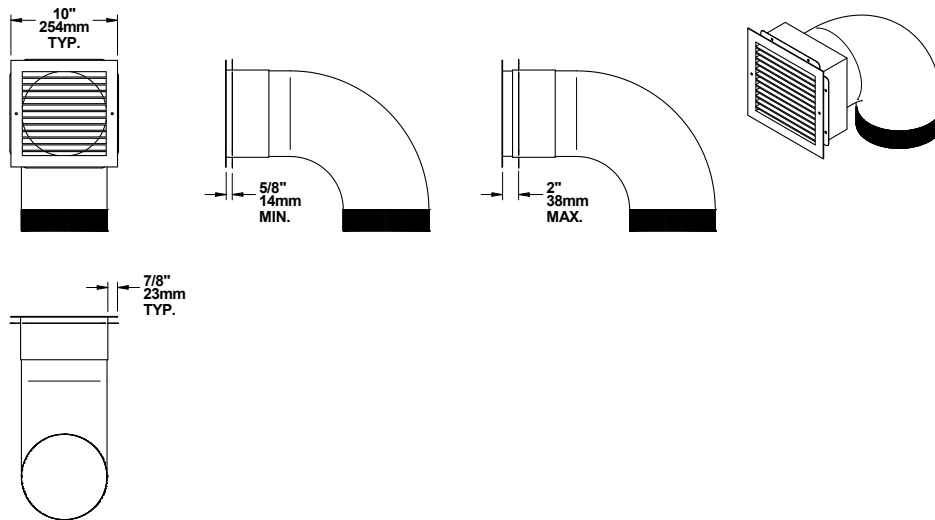

Installation rules and advice

- The minimum height of the hot air duct is 68" (1.7 m). It must be measured from the base of the fireplace to the top of the hot air outlets.
- Do not connect the hot air ducts to a central heating system. The malfunction of the heating system would overheat the fireplace.
- Do not use insulated flexible ducts as they may overheat.
- Do not use «T» fittings or anything other than those listed below.
- All ducts must be placed vertically or horizontally. **Never route the ducting downwards.**
- The flaps of the hot air outlet grilles must point down to prevent overheating of the adjacent ceilings.
- Always install both hot air outlet grilles when the hot air gravity kit is installed.
- The hot air outlets can be installed in the same room as the fireplace, or both can be installed in adjacent rooms or upstairs. If the outlets are installed at different heights, the higher outlet will draw more heat.
- When forced air kit is installed in conjunction with a gravity kit, the forced air device will draw some of the air from the gravity kit ducting, therefore reducing its efficiency.

Clearances

- Maximum length of pipes, including elbows: 10' (3 m)
- The maximum number of elbows allowed per duct is two.
- There shall be a clearance of at least 12" (305 mm) between the hot air outlet frame and a ceiling, side wall or mantle made of flammable material.
- When the duct passes through a wall or floor made of flammable material, a firestop radiation shield (same as the one used for a class A chimney) must be installed in the opening of the wall or floor. There must be a clearance of at least 2" (51 mm) between the ducts and the firestop.

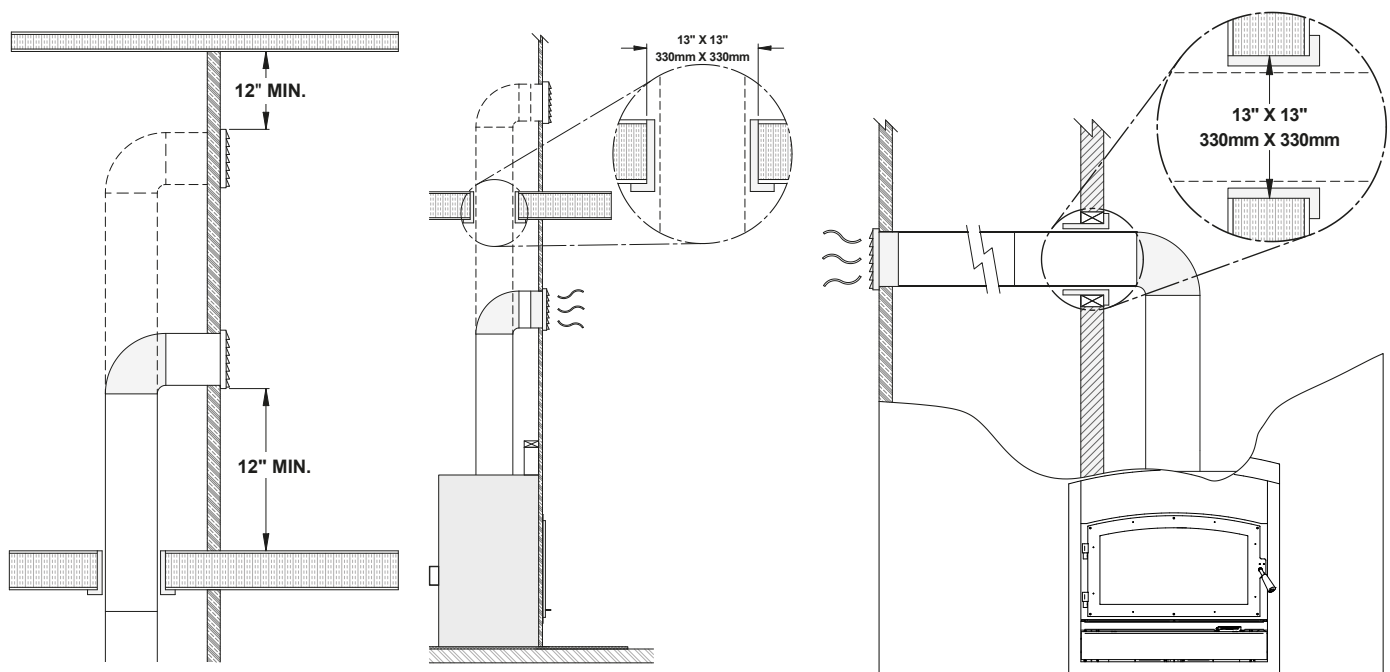

Installation



It is strongly recommended to wear gloves to complete the installation.

- A) Remove the knockout that close the 8" (20 cm) diameter holes on top of the fireplace. Then cut and remove the insulation and the other set of knockout inside the fireplace.

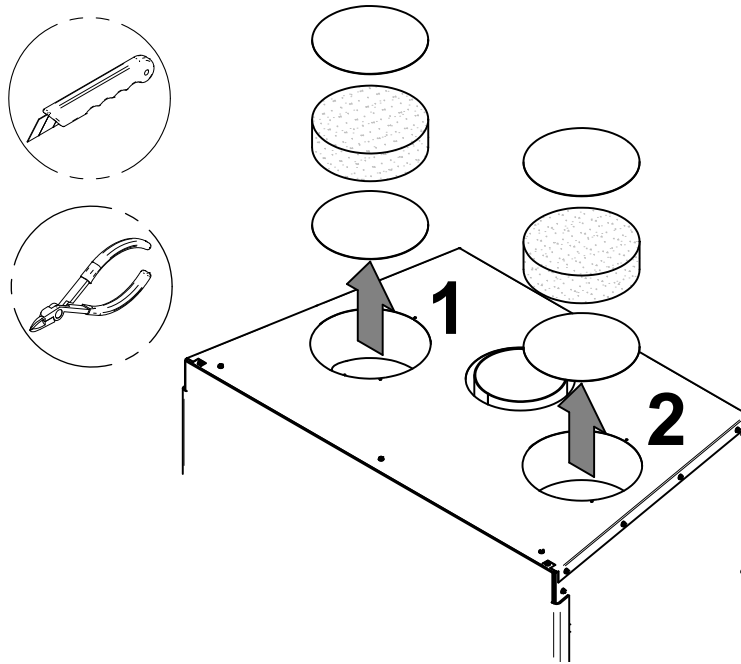

- B) Screw 6 steel brackets (**D**) with 6 screws (**E**) onto the top of the fireplace (3 per duct). Insert the ducts (**G**) (not supplied) into each opening. Position the ducts as shown in the section view below, for optimal heat capture. Screw each duct in place in the brackets (**D**) with 6 self-drilling screws (**F**).

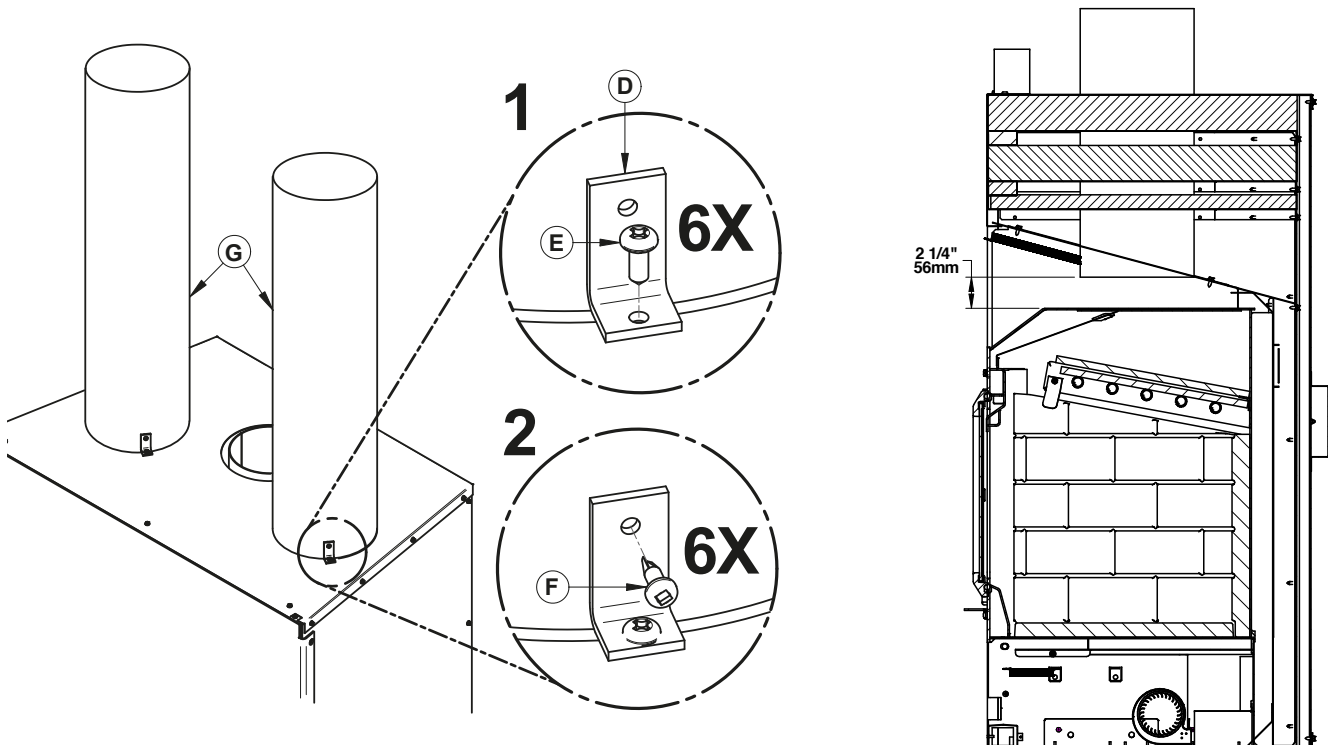

6.4 Optional Forced Air Distribution Kit Installation

It is possible to connect a forced air kit on the back or on either side of the Everest II. This kit allows distributing heat to another room up to 50 feet (15 m) of the fireplace. The insulated flexible pipe (not included in the kit) must be HVAC type pipe and must comply with ULC S110 and/or UL 181, Class 0 or Class 1 Standards and must withstand temperatures up to 250 °F.

For the complete installation procedure, see the installation manual provided with the kit. You can also download this manual at www.osburn-mfg.com.

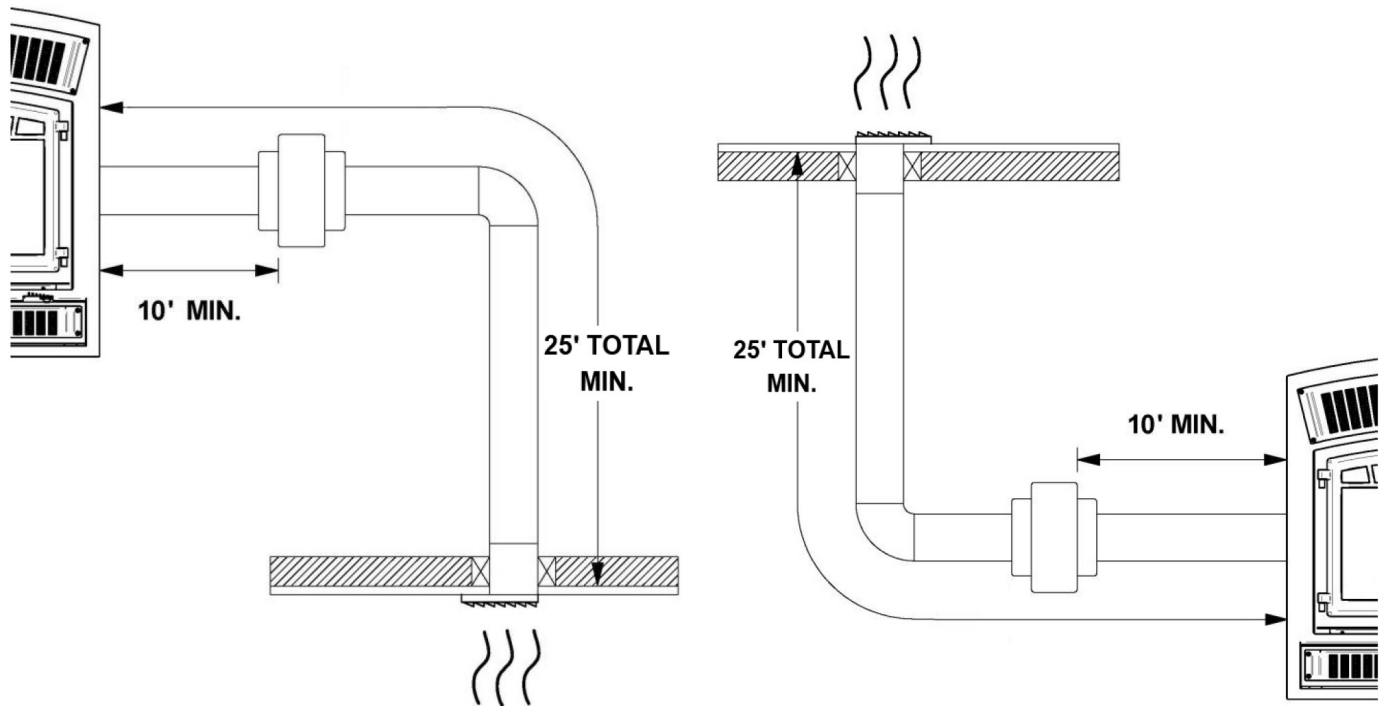

ENGLISH

*The EPA standard states that it is necessary to perform certification testing with any ventilation that is likely to alter the units' performance. For this reason, SBI has tested the effects of the forced air kit on the emissions of fine particles. Due to the design of our appliance and more specifically to the temperature sensor that is installed to control stops and starts, the forced art kit does not affect the emission results. In fact, this option promotes the recovery of excess heat to later redistribute it to other rooms. During our testing, it was noted that the convection blowers underneath the firebox had more of an effect on the fine particles emission due to the air being directed onto the firebox thus cooling the unit. However, this appliance has already been tested for emission

6.5 Optional Fire Screen Installation

In the United States or in provinces with a particulate emissions limit (e.g.: US EPA), the use of open-door wood fireplace with a rigid firescreen is prohibited.

A firescreen door can be installed on the fireplace. For more details, refer to the installation manual supplied with the firescreen.

Warning: Never leave the fireplace unattended while in use with the firescreen.

It is prohibited to use this wood fireplace with a fire screen in a mobile home (In Canada only).

1. Open the doors.

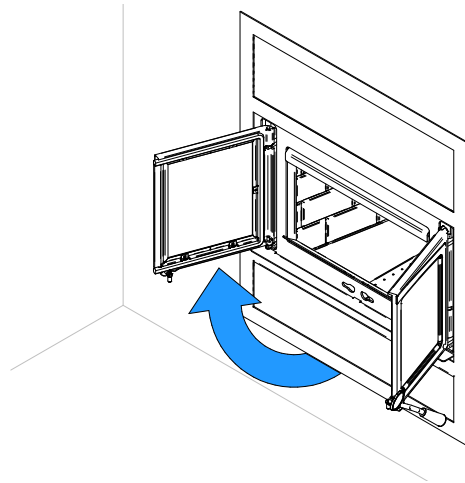

2. Hold the firescreen and bring it close to the door opening.

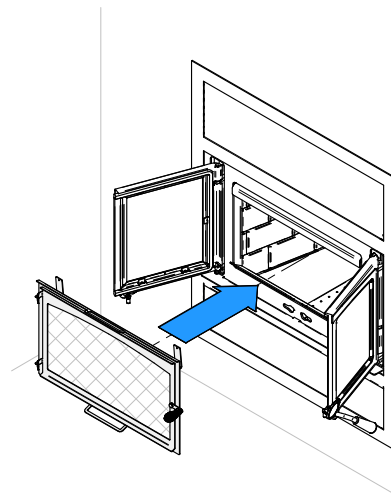

3. Lean the upper part of the firescreen against the top door opening making sure to insert the top firescreen bracket behind the primary air deflector.

4. Lift the firescreen upwards and push the bottom part towards the fireplace then let the firescreen rest on the bottom of the door opening.

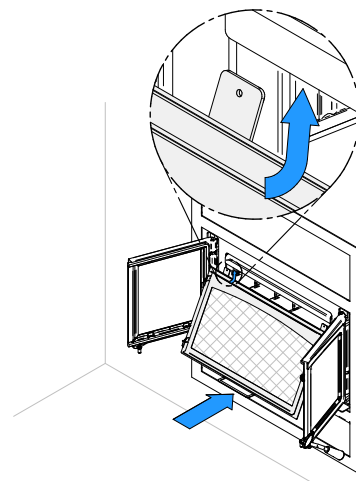

7. REPLACEMENT OF PARTS ON YOUR PRODUCT

7.1 Refractory Panels Replacement

1. Remove the channel first (see **section 7.7 Removing the air channel**) and then remove the floor refractory panels (**E**) without risk of breaking anything.
2. Using a power driver, remove the refractory panel brackets (**G**) and the side refractory panels (**I**).

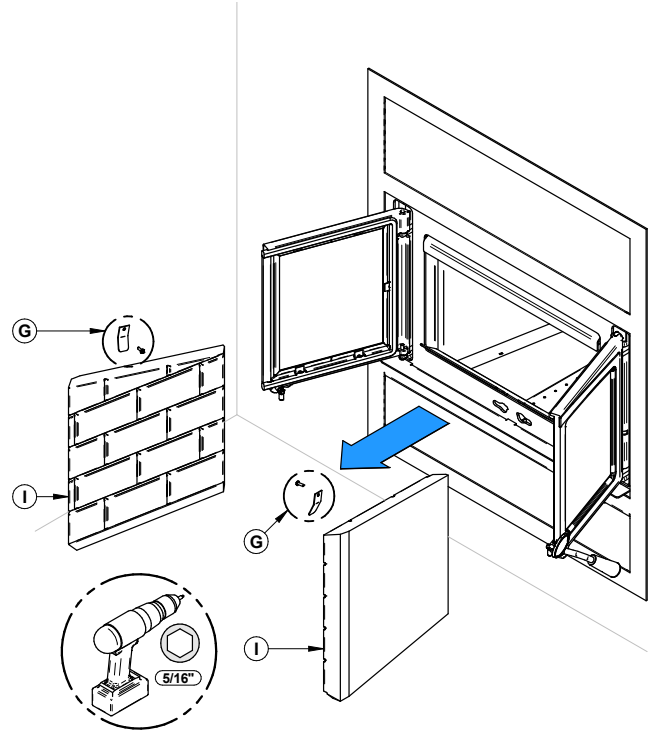
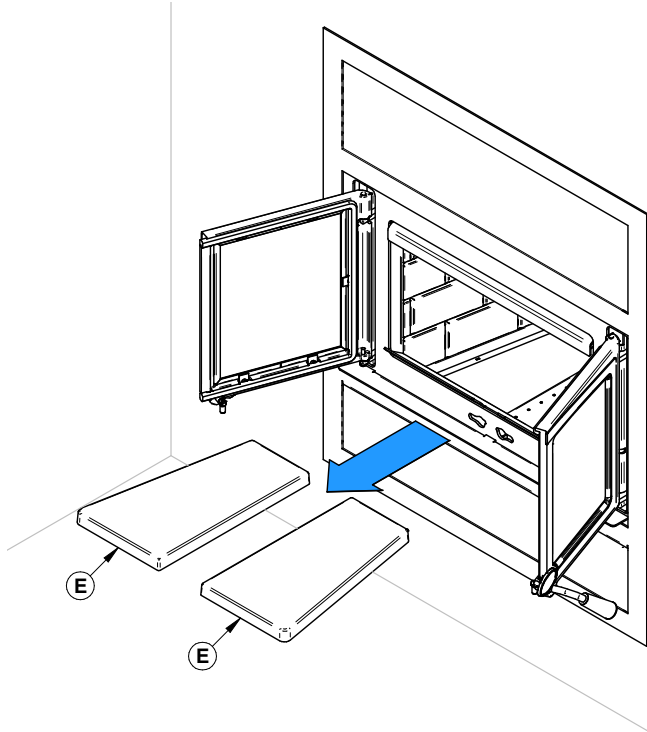

3. Remove the back refractory panel (**F**).

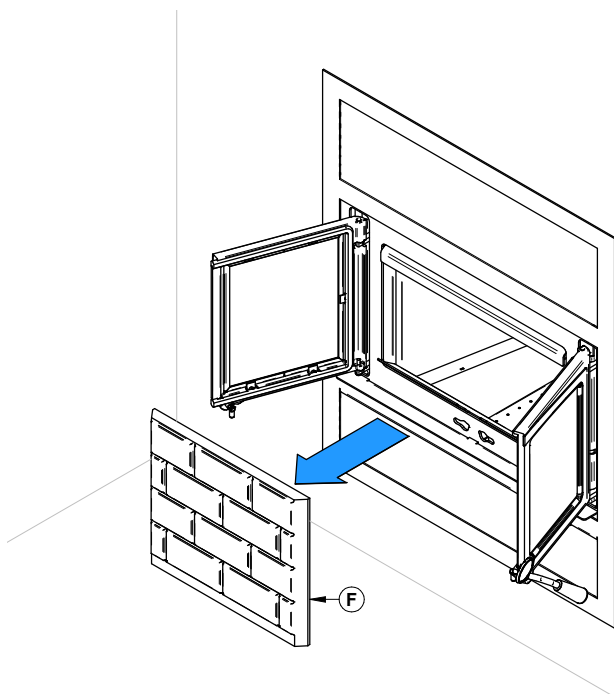

7.2 Secondary Air Tubes and Baffle Installation

1. Starting with the rear tube, lean and insert the right end of the secondary air tube into the rear right channel hole. Then lift and insert the left end of the tube into the rear left channel.

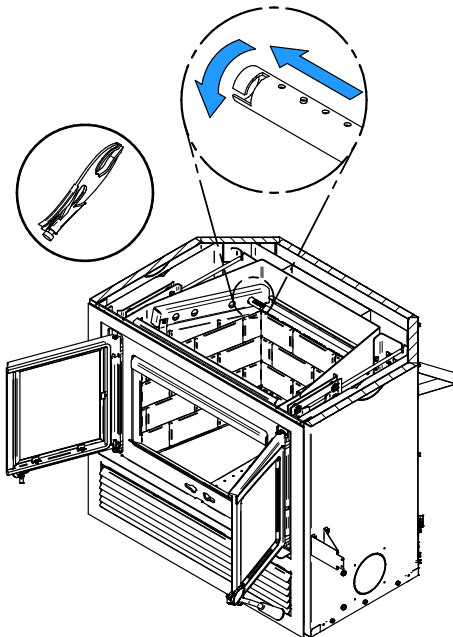
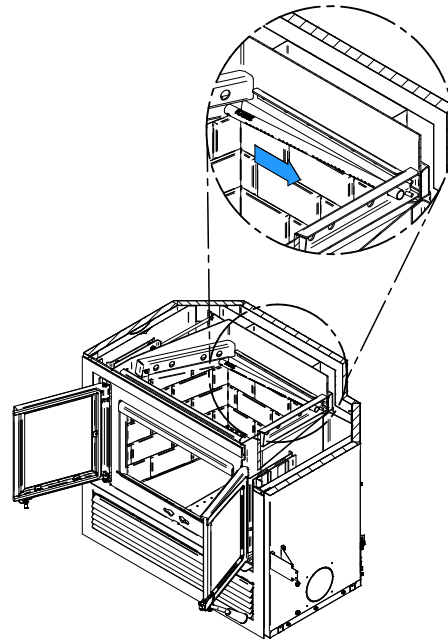

2. Align the notch in the left end of the tube with the key of the left air channel hole. Using a «Wise grip» hold the tube and lock it in place by turning the tube as shown. Make sure the notch reaches the end of the key way.
3. Repeat for center back tube.
4. Put the baffle in place.
5. Repeat steps 1 and 2 for the two front tubes.
6. To remove the tubes use the above steps in reverse order.

Note that secondary air tubes (A) can be replaced without removing the baffle board (B).

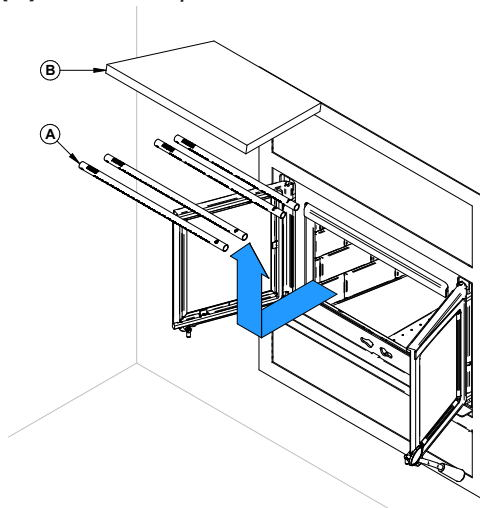

7.3 Mobile Home Installation

Installation permitted in a mobile home in Canada only.

Screw the fireplace on the floor with the proper hardware.

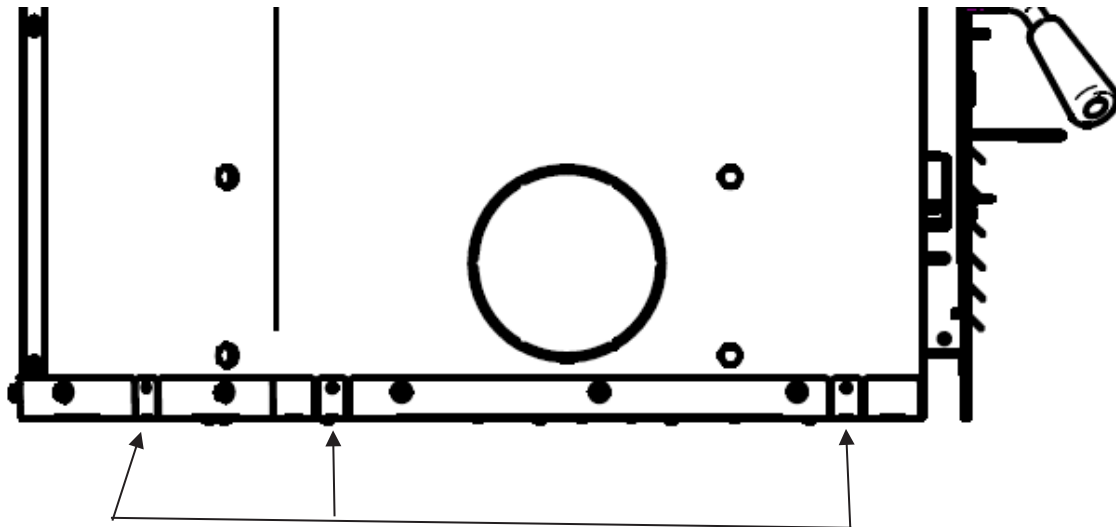

ENGLISH

CAUTION

- Installation of this fireplace in a mobile home is permitted in Canada only. Do not install in a manufactured home in USA.
- **WARNING : DO NOT INSTALL IN THE SLEEPING ROOM OF A MOBILE HOME.**
- **THIS FIREPLACE MUST BE SECURED TO THE STRUCTURE OF THE MOBILE HOME.**
- **CAUTION : THE STRUCTURAL INTEGRITY OF THE MOBILE HOME FLOOR, WALL, CEILING AND ROOF MUST BE MAINTAINED.**
- **IT IS PROHIBITED TO USE THIS WOOD FIREPLACE WITH A FIRE SCREEN IN A MOBILE HOME.**

7.4 Blower replacement

To facilitate the blower replacement, it is recommended to remove the faceplate first. Refer to the faceplate installation manual for more details.

1. Take off the faceplate

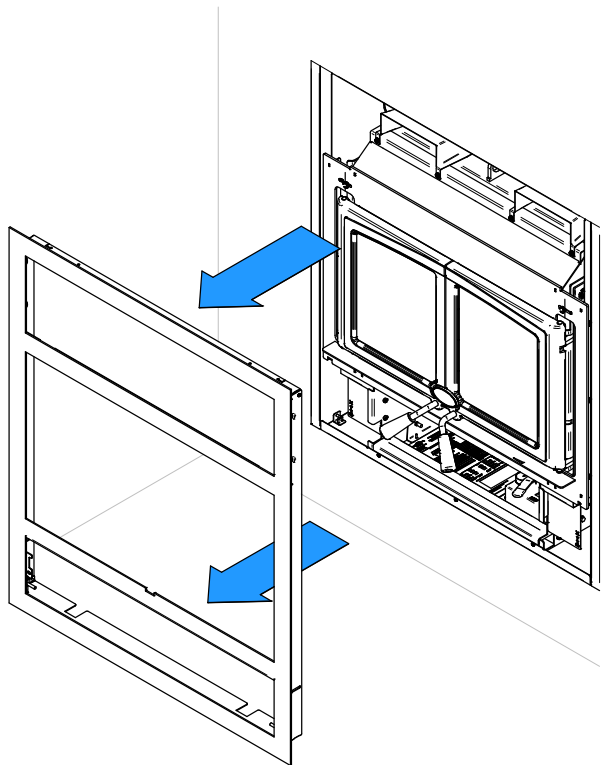

2. Cut the ty-rap. Lift the blower **(A)** located under the firebox towards the back. Turn 90° to pull out.

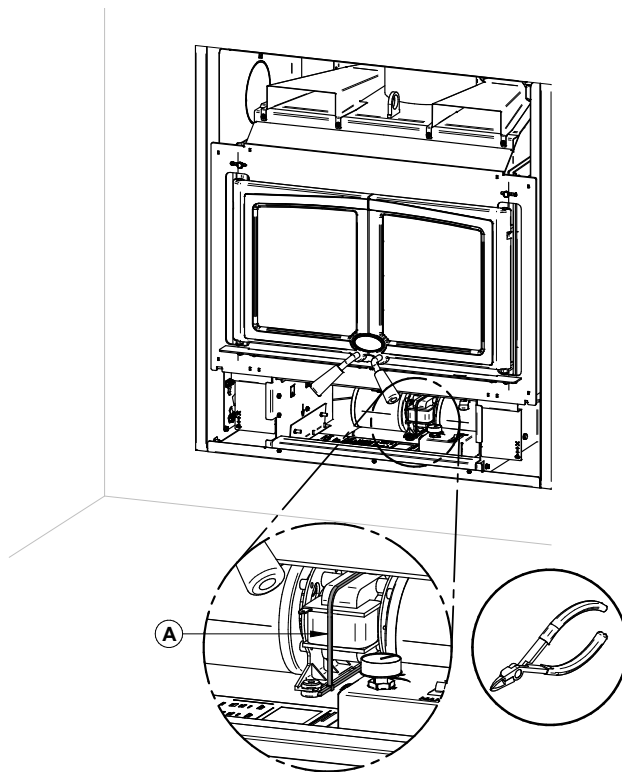

3. Remove the ground **(B)** from the fireplace.

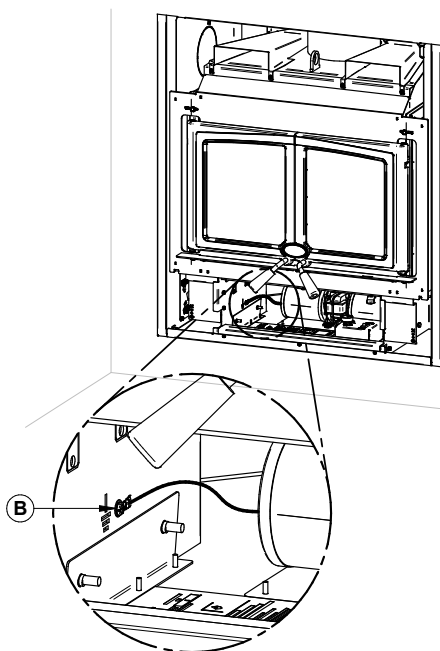

4. Unplug the wires and unplug the blower's electric wires **(P)** and **(Q)**.

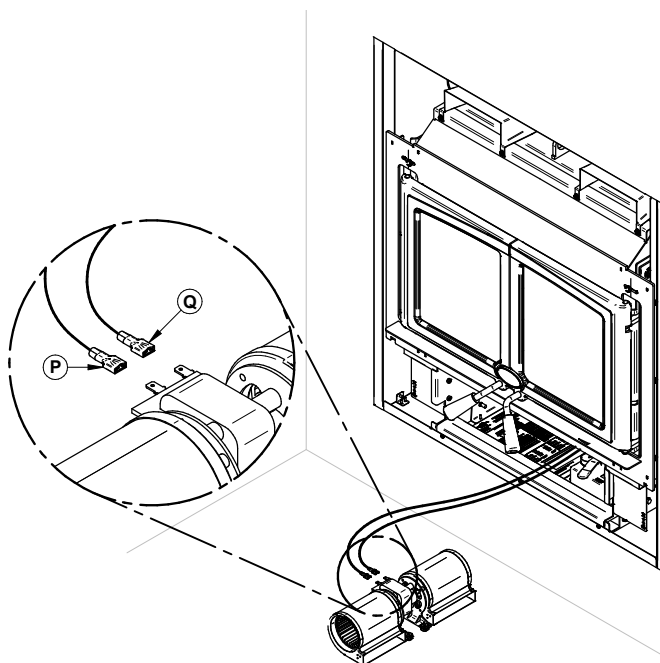

5. Repeat the steps in reverse order to reinstall the blower.

Blower Connection

The wiring should be done by a qualified electrician. The ground (green or skinned wire) must be attached to the fireplace metal frame.

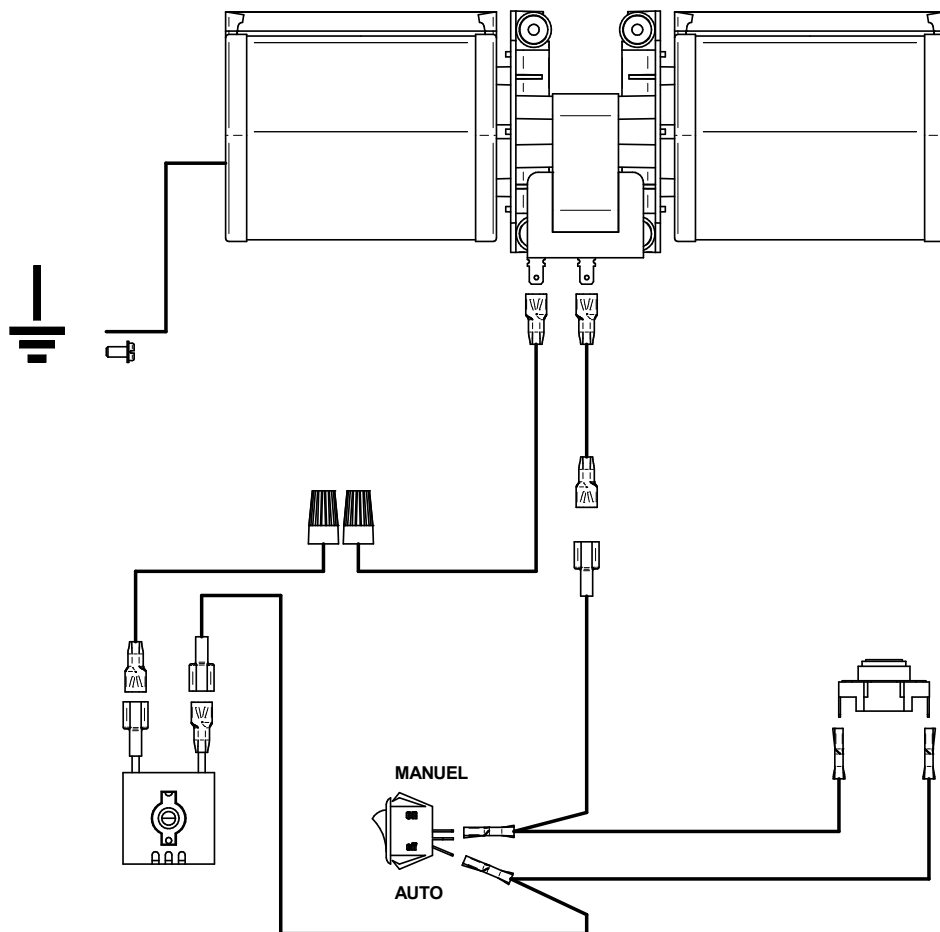

7.5 Glass Door

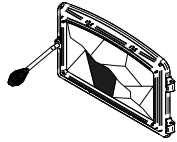

Do not clean the glass when the fireplace is hot.
Do not abuse the glass door by striking or slamming shut.
Do not use the fireplace if the glass is broken.

7.5.1 Replacement

The glass used is a ceramic glass, 5/32" (4 mm) thick, 12 1/2" x 11 1/8" (319 mm x 283 mm) tested to reach temperatures up to 1400° F. If the glass breaks, it must be replaced by a ceramic glass from SCHOTT with the same specification. **Tempered glass or ordinary glass will not withstand the high temperatures of this unit.**

WARNING: DO NOT USE SUBSTITUTE MATERIALS WHEN REPLACING THE GLASS.

To replace the glass, use the following procedure;

Remove the glass retaining screws **(A)** and clips **(B)** then the metal frames **(C)** that hold the glass **(D)** to the door frame **(E)**. Lift out the glass **(D)** and pull off the old gasket. Do the same for the other door.

This is a good time to clean the glass thoroughly.

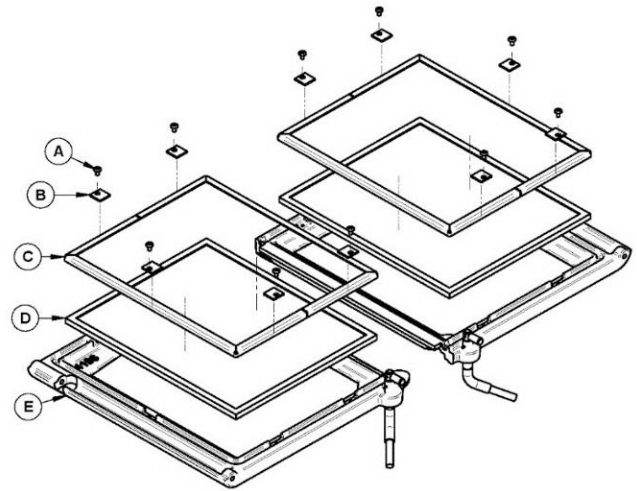

7.5.2 Gasket

The glass gasket is flat, adhesive-backed, woven fibreglass. The gasket must be centred on the edge of the glass.

1. Follow the steps of the previous section to remove the glass.
2. Remove the old gasket and clean the glass thoroughly.
3. Peel back a section of the paper covering the adhesive and place the gasket on a table with the adhesive side up.
4. Stick the end of the gasket to the middle of one edge, then press the edge of the glass down onto the gasket, taking care that it is perfectly centred on the gasket. Peel off more of the backing and rotate the glass. The gasket must not be stretched during installation.
5. Cut the gasket to the required length. Pinch the gasket onto the glass in a U-shape, all around the glass.

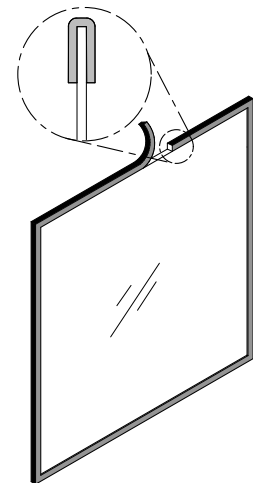

7.6 Door

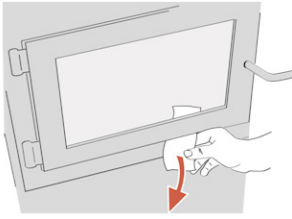

In order for the fireplace to burn at its best efficiency, the door must provide a perfect seal with the firebox. Therefore, the gasket should be inspected periodically to check for a good seal. The tightness of the door seal can be verified by closing and latching the door on a strip of paper. The test must be performed all around the door. If the paper slips out easily anywhere, either adjust the door or replace the gasket.

At the end of each heating season it is recommended to add a high temperature graphite paste on the threads of the door handles. This paste will protect the threads from rust and prevent dust accumulation that can prevent the handles from rotating freely.

7.6.1 Adjustment

The door seal may be improved with a simple latch mechanism adjustment on the right door:

1. Remove the split pin by pulling and turning it using pliers.

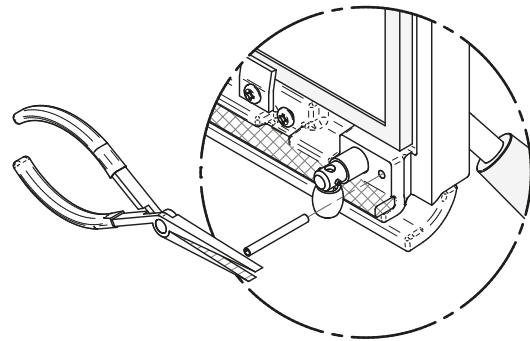

2. Turn the handle one counterclockwise turn to increase pressure.

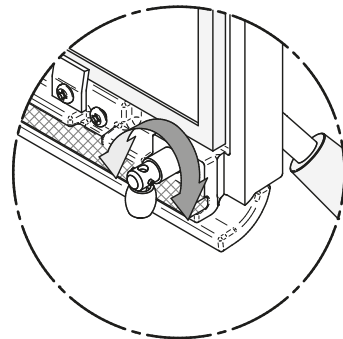

3. Reinstall the split pin with a small hammer.

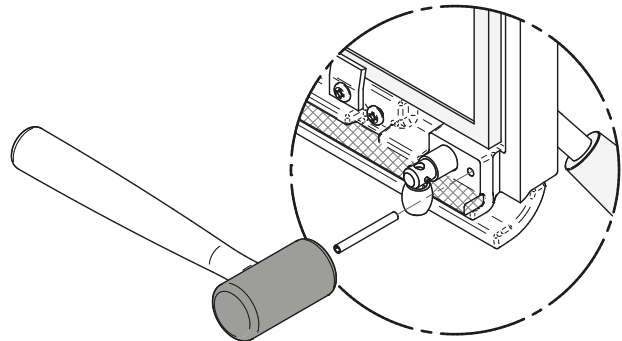

7.6.2 Gasket

Use the correct replacement gasket: **(A)** for the doors and **(B)** for the doors junction. Both can be purchased from your retailer. The diameter and density of the gasket is important to getting a good seal.

Place the doors face-down on something soft like a cushion of rags or piece of carpet. Remove the old gaskets from the door by pulling and prying it out with an old screw driver. Then use the screwdriver to scrape the old gasket adhesive from the door. Now run a 1/4" (6 mm) bead of high temperature silicone in the door frame gasket groove of the door gasket. Starting from the middle of the hinge side, press the gasket into the groove. Do not stretch the gasket as you place it. Leave the gasket about 1/2" (13 mm) long when you cut it and press the end into the groove. Tuck any loose fibres under the gasket and into the silicone. Do the same for center door gaskets. Repeat for the other door. Close the door and do not use the fireplace for 24 hours.

ENGLISH

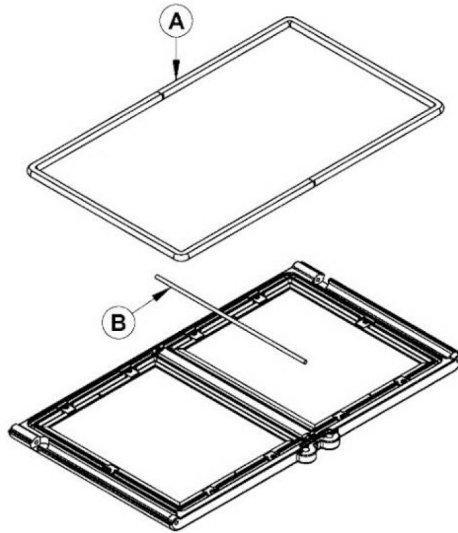

Location	Length	Dimension
On each door frame	38" (96 cm)	Round 5/8" (16 mm)
Center door gasket	14" (36 cm)	Round 1/4" (6 mm) self-adhesive

7.7 Removing The Air Channel

The underside of the air channel located at the bottom of the combustion chamber must be cleaned annually in order to maintain its efficiency. To do this, start by unscrewing the bolt **(A)** at the front end of the channel, pull the channel forward to unhook it from the bottom. The channel can now be removed from the fireplace.

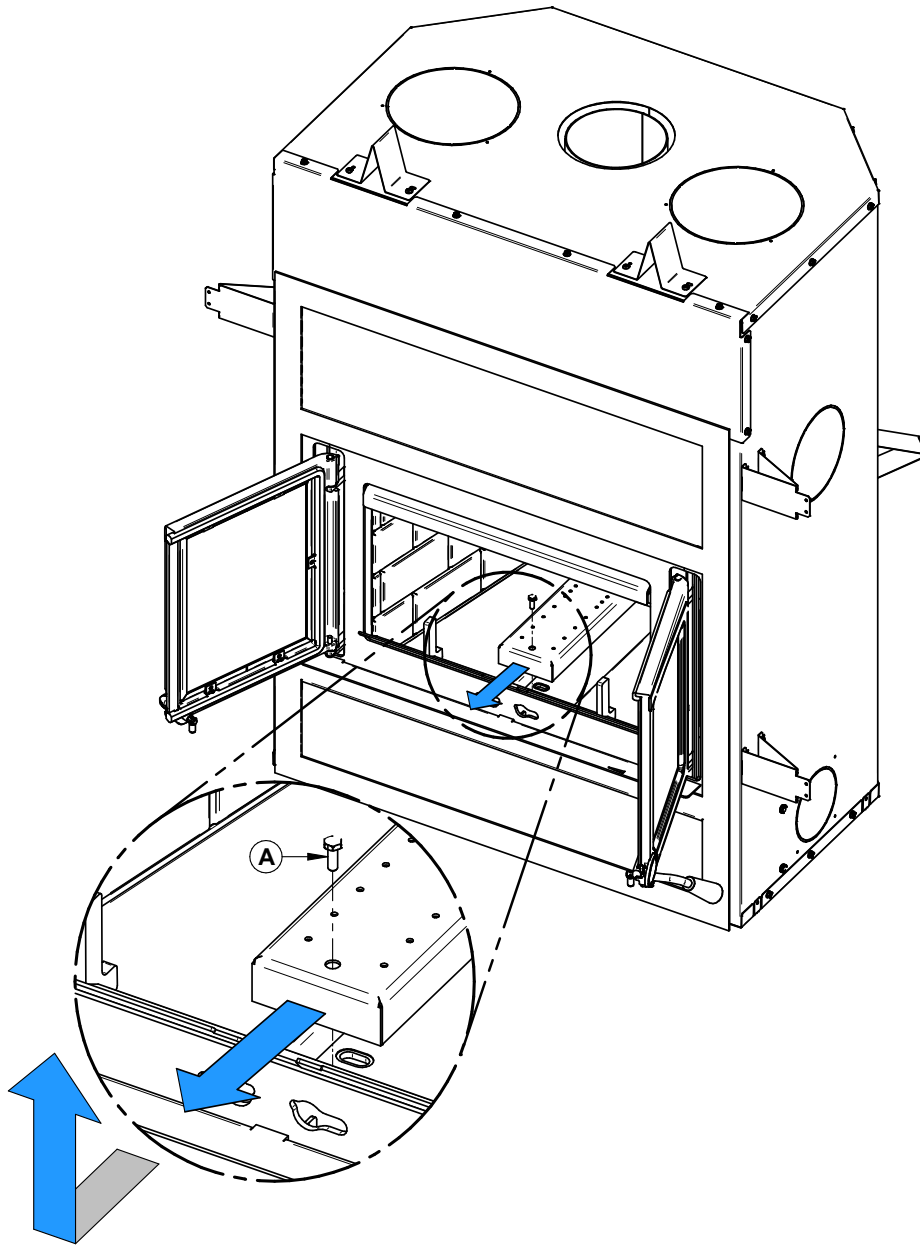

8. Exploded Diagram and Part List

ENGLISH

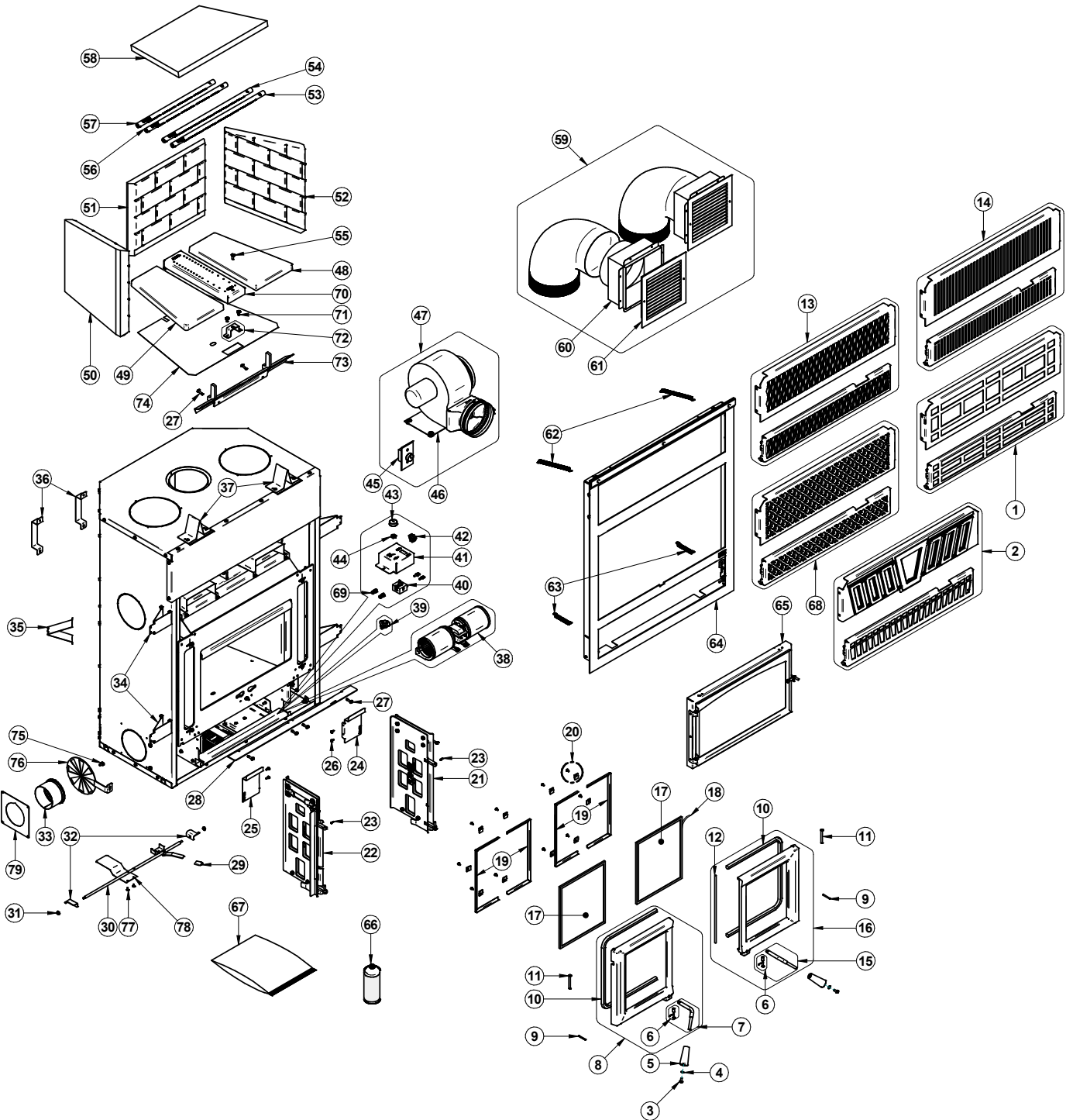

IMPORTANT: THIS IS DATED INFORMATION. When requesting service or replacement parts for your unit, please provide the model number and the serial number. We reserve the right to change parts due to technology upgrades or availability. Contact an authorized dealer to obtain any of these parts. Never use substitute materials. Use of non-approved parts can result in poor performance and safety hazards.

#	Item	Description	Qté
1	VA18L09	MISSION STYLE FACEPLATE LOUVER	1
2	VA18L10	CROWN STYLE FACEPLATE LOUVER	1
3	30025	1/4-20 X 1/2" PAN-HEAD QUADREX BLACK SCREW	2
4	30187	STAINLESS WASHER ID 17/64" X OD 1/2"	2
5	30898	ROUND WOODEN BLACK HANDLE	2
6	SE36580	LATCH KIT	2
7	SE70409	LEFT HANDLE AND LATCH KIT	1
8	SE24374	LEFT DOOR ASSEMBLY WITH GASKET AND HANDLE	1
9	30101	SPRING TENSION PIN 5/32"Ø X 1 1/2"L	2
10	AC06500	SILICONE AND 5/8" X 8' BLACK DOOR GASKET KIT	2
11	30877	HINGE PIN 1/4"Ø X 2-1/2"L	2
12	40030	6 mm GASKET	3
13	VA18L06	CLASSIQUE STYLE FACEPLATE LOUVER	1
14	VA18L08	URBAN STYLE FACEPLATE LOUVER	1
15	SE70410	RIGHT HANDLE AND LATCH KIT	1
16	SE24375	RIGHT DOOR ASSEMBLY WITH GASKET AND HANDLE	1
17	SE75000	REPLACEMENT GLASS WITH GASKET 10 5/16" X 12 7/16"	2
18	AC06400	3/4" X 6' X 1/8" FLAT BLACK SELF-ADHESIVE GLASS GASKET	1
19	PL75050	GLASS FRAME	4
20	SE63024	GLASS RETAINERS WITH SCREWS KIT (10 UNITS)	1
21	SE70479	RIGHT CHARIOT ASSEMBLY	1
22	SE70477	LEFT CHARIOT ASSEMBLY	1
23	30143	SOCKET SET SCREW #10-32 X 1/2"	2
24	PL70439	RIGHT PLUG FACEPLATE	1
25	PL70425	LEFT PLUG FACEPLATE	1
26	30154	BLACK ZINC SCREW #10 X 5/8" QUADREX #2 TYPE A	2
27	30506	BLACK SCREW PAN TORX TYPE F 1/4-20 X 1"	6
28	PL70483	ASH TRAY	1
29	30556	AIR CONTROL FINISHING TIP	1
30	SE70443	AIR CONTROL ASSEMBLY	1
31	30220	FLANGED LOCKNUT 1/4-20	2
32	PL73254	AIR HATCH	2
33	PL63954	4" ADAPTOR	1
34	PL70463	SIDE STAND-OFF	4
35	PL70424	SIDE REAR STAND-OFF	2

ENGLISH

#	Item	Description	Qté
36	PL70452	REAR STAND-OFF	2
37	PL70453	TOP STAND-OFF	2
38	44207	DOUBLE CAGE BLOWER 176 CFM (CLASS H)	1
39	VA1150	THERMODISC F110-20F	1
40	44080	RHEOSTAT WITHOUT NUT (MODEL KBMS-13BV)	1
41	PL70113	TERMINAL BOX	1
42	44091	ROCKER SWITCH 2 POSITION MSR-8	1
43	44085	RHEOSTAT KNOB	1
44	44087	RHEOSTAT NUT	1
45	44131	SPEED CONTROL (2.5 A)	1
46	44121	FORCED AIR KIT BLOWER 6" - 2.4A	1
47	VA4460	FORCED AIR KIT	1
48	22354	RIGHT FLOOR REFRACTORY STONE	1
49	22353	LEFT FLOOR REFRACTORY STONE	1
50	22355	LEFT REFRACTORY STONE	1
51	22357	REAR REFRACTORY STONE	1
52	22356	RIGHT REFRACTORY STONE	1
53	PL70107	FRONT SECONDARY AIR TUBE	1
54	PL70407	CENTER FRONT SECONDARY AIR TUBE	1
55	30785	MECHANICAL SCREW 1/4-20 X 3/4" STAINLESS HEX	1
56	PL73251	MIDDLE REAR SECONDARY AIR TUBE	1
57	PL73250	REAR SECONDARY AIR TUBE	1
58	21686	BAFFLE 20-1/4" X 15-1/2" X 13-3/8"	1
59	AC01375	TRADITIONAL GRAVITY KIT	1
60	30640	GALVANISED BOX FOR GRAVITY KIT 8"	2
61	30540	GRILL FOR GRAVITY KIT	2
62	30767	SPRING 1/2"Ø OUTSIDE X 8"L	2
63	30472	SPRING 1/2" OUTSIDE Ø X 3"L	2
64	VA18FL07	BLACK SQUARE FACEPLATE	1
65	AC01226	FIRESCREEN DOOR	1
66	AC05959	METALLIC BLACK STOVE PAINT - 342 g (12oz) AEROSOL	1
67	SE464001	FP18R INSTRUCTION MANUAL KIT	1
68	VA18L07	ARABESQUE STYLE FACEPLATE LOUVER	1
69	44077	WIRE CONNECTION WITH WINGS YELLOW 18-10 AWG	2
70	PL73262	PILOT PIPE	1
71	30060	SCREW 1/4-20 X 1/2" HEX #3/8 SLOT WASHER TYPE F ZINC	2
72	PL73271	ATTACHEMENT SUPPORT	1
73	SE73263	ASS. ADIRON ASHTRAY	1
74	PL73266	BOTTOM PROTECTION	1
75	30084	BOLT 1/4-20 X 1/2" GRADE 5	1

#	Item	Description	Qté
76	PL73259	COLD AIR SYSTEM	1
77	30124	MECHANICAL SCREW #8-32 X 5/16" TRUSS QUADREX #2 ZINC	2
78	PL73255	HATCH	1
79	PL73269	FRESH AIR CONNECTION PLATE	1

VALCOURT LIMITED LIFETIME WARRANTY

The warranty of the manufacturer extends only to the original consumer purchaser and is not transferable. This warranty covers brand new products only, which have not been altered, modified nor repaired since shipment from factory. Proof of purchase (dated bill of sale), model name and serial number must be supplied when making any warranty claim to your VALCOURT dealer.

This warranty applies to normal residential use only. This warranty is void if the unit is used to burn material other than cordwood (for which the unit is not certified by EPA) and void if not operated according to the owner's manual. Damages caused by misuse, abuse, improper installation, lack of maintenance, over firing, negligence or accident during transportation, power failures, downdrafts, or venting problems are not covered by this warranty.

This warranty does not cover any scratch, corrosion, distortion, or discoloration. Any defect or damage caused by the use of unauthorized parts or others than original parts void this warranty. An authorized qualified technician must perform the installation in accordance with the instructions supplied with this product and all local and national building codes. Any service call related to an improper installation is not covered by this warranty.

The manufacturer may require that defective products be returned or that digital pictures be provided to support the claim. Returned products are to be shipped prepaid to the manufacturer for investigation. If a product is found to be defective, the manufacturer will repair or replace such defect. Transportation fees to ship the product back to the purchaser will be paid by the manufacturer. Repair work covered by the warranty, executed at the purchaser's domicile by an authorized qualified technician requires the prior approval of the manufacturer. Labour cost and repair work to the account of the manufacturer are based on predetermined rate schedule and must not exceed the wholesale price of the replacement part. All parts and labour costs covered by this warranty are limited according to the table below.

The manufacturer at its discretion may decide to repair or replace any part or unit after inspection and investigation of the defect. The manufacturer may, at its discretion, fully discharge all obligations with respect to this warranty by refunding the wholesale price of any warranted but defective parts. The manufacturer shall in no event be responsible for any special, indirect, consequential damages of any nature, which are in excess of the original purchase price of the product. **A one-time replacement limit applies to all parts benefiting from a lifetime coverage.** This warranty applies to products purchased after May 1st, 2021.

DESCRIPTION	WARRANTY APPLICATION	
	PARTS	LABOUR
Combustion chamber (welds only), castings, convector air-mate and ceramic glass*	Lifetime**	4 years
Plating* (defective manufacture) - subject to limitations above	Lifetime**	n/a
Stainless steel firebox components, surrounds and heat shields, trims (aluminum extrusions), vermiculite, C-Cast or equivalent baffle*, and secondary air tubes*	5 years**	3 years
Carbon steel firebox components, glass retainers, and handle assembly	3 years	2 years
Grate, blowers, heat sensors, switches, rheostat, wiring, and other controls	2 years	1 year
Paint (peeling), gaskets, insulation, refractory bricks**, and ceramic fibre blankets	1 year	n/a
All parts replaced under the warranty	90 days	n/a

*Pictures required **Limited to one replacement

Shall your unit or a components be defective, contact immediately your VALCOURT dealer. Prior to your call make sure you have the following information necessary to your warranty claim treatment:

- Your name, address and telephone number
- Nature of the defect and any relevant information
- Bill of sale and dealer's name
- Serial number and model name as indicated on the nameplate fixed to the back of your unit

Before shipping your unit or defective component to our plant, you must obtain from your VALCOURT dealer an Authorization Number. Any merchandise shipped to our plant without authorization will be refused automatically and returned to sender.

Wood_Revision: May 2021

This document is available for free download on the manufacturer's website. It is a copyrighted document. Resale is strictly prohibited. The manufacturer may update this document from time to time and cannot be responsible for problems, injuries, or damages arising out of the use of information contained in any document obtained from unauthorized sources.

The logo for Valcourt, featuring the word "Valcourt" in a stylized, cursive script font.

Stove Builder International inc.
250, De Copenhague street,
St-Augustin-de-Desmaures (Québec), Canada
G3A 2H3
1-877-356-6663
<https://www.valcourtinc.com/en/>
tech@sbi-international.com