



Installation and Operation Manual

Safety tested according to ULC S627, UL 1482 and UL 737 standards by an accredited laboratory.

SOLUTION 2.3 (EB00041 model)

ENGLISH

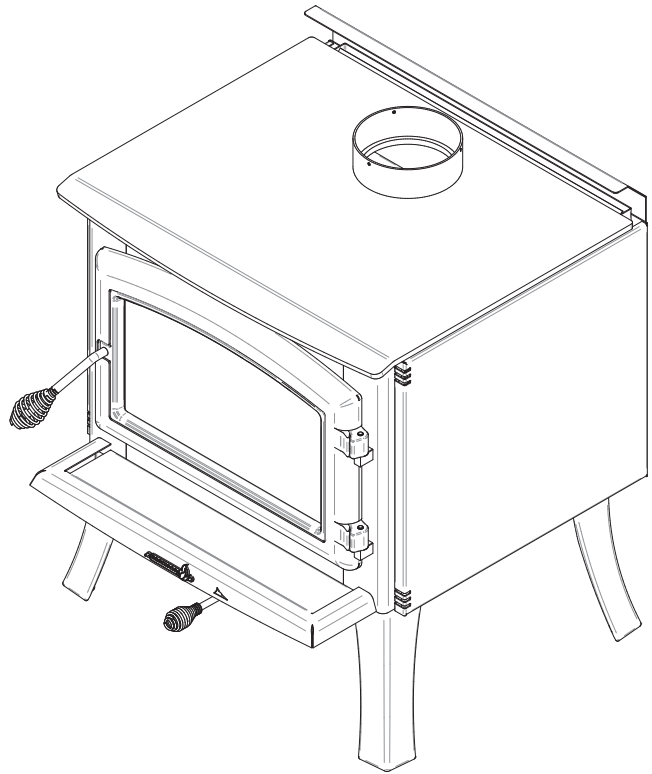
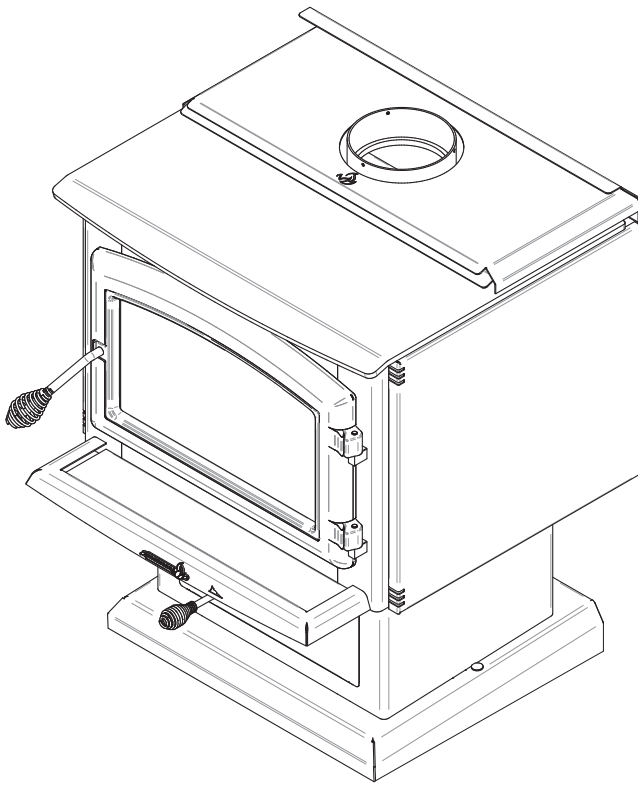

US Environmental Protection Agency phase II certified wood stove compliant with 2020 cord wood standard.

CONTACT LOCAL BUILDING OR FIRE OFFICIALS ABOUT RESTRICTIONS AND INSTALLATION INSPECTION REQUIREMENTS IN LOCAL AREA.

READ THIS ENTIRE MANUAL BEFORE INSTALLATION AND USE OF THIS WOOD STOVE. FAILURE TO FOLLOW THESE INSTRUCTIONS COULD RESULT IN PROPERTY DAMAGE, BODILY INJURY OR EVEN DEATH.

READ AND KEEP THIS MANUAL FOR REFERENCE

THANK YOU FOR CHOOSING THIS WOOD STOVE.

If this stove is not installed properly, combustible materials near it may overheat and catch fire.

To reduce the risk of fire, follow the installation instructions in this manual.

As one of North America's largest and most respected wood stove and fireplace manufacturers, Stove Builder International takes pride in the quality and performance of all its products.

The following pages provide general advice on wood heating, detailed instructions for safe and effective installation, and guidance on how to get the best performance from this stove.

It is highly recommend that this wood burning hearth product be installed and serviced by professionals who are certified by a «Qualified Agency» such as NFI (National Fireplace Institute®) or CSIA (Chimney Safety Institute of America) in the United States and in Canada by WETT (Wood Energy Technology Transfer) or in Quebec by APC (Association des Professionnels du Chauffage).

Contact local building or fire officials about restrictions and installation inspection requirements in local area.

A building permit might be required for the installation of this stove and the chimney that it is connected to. It is also recommended to inform your home insurance company.

Please read this entire manual before installing and using this stove.

A primary alternative heat source should be available in the home. This heating unit may serve as a supplementary heat source. The manufacturer cannot be responsible for additional heating costs associated with the use of an alternative heat source.

ONLINE WARRANTY REGISTRATION

If the unit requires repairs during the warranty period, proof of purchase must be provided. The purchase invoice must be kept. The date indicated on it establishes the warranty period. If it can not be provided, the warranty period will be determined by the date of manufacture of the product.

It is also highly recommended to register the warranty online at

<https://www.enerzone-intl.com/en/warranty/warranty-registration/>

Registering the warranty will help to quickly find the information needed on the unit.

TABLE OF CONTENTS

PART A - OPERATION AND MAINTENANCE	7
1. Safety Information	7
2. General Information.....	8
2.1 Performances	8
2.2 Specifications	9
2.3 Dimensions.....	10
2.4 Zone Heating and How to Make it Work for You	15
2.5 The Benefits of Low Emissions and High Efficiency	15
2.6 The SBI Commitment to You and the Environment	15
3. Fuel	16
3.1 How to Prepare or Buy Good Firewood	17
4. Operating Your Stove	19
4.1 Before Operating Your Stove	19
4.2 The Use of a Fire Screen	19
4.3 The First Fires.....	20
4.4 Lighting Fires.....	21
4.5 Maintaining Wood Fires	22
4.6 Building Different Fires for Different Needs.....	24
5. Maintaining Your Wood Heating System.....	26
5.1 Stove Maintenance	26
5.2 Chimney Maintenance	29
PART B - INSTALLATION.....	30
6. Safety Information and Standards.....	30
6.1 Mobile Home	30
6.2 Regulations Covering Stove Installation	30
7. Clearances to Combustible Material	31
7.1 Location of the Certification Label.....	31
7.2 Clearances to Combustible Materials	31
7.3 Floor Protector	36
7.4 Reducing Wall and Ceiling Clearances Safely	37
8. The Venting System.....	40
8.1 General	40
8.2 Suitable Chimneys	40
8.3 Minimum Chimney Height.....	42
8.4 The Relationship Between the Chimney and the House	42
8.5 Supply of Combustion Air.....	43
8.6 Installing the Chimney Connector.....	44

Appendix 1 : Legs Installation 47
Appendix 2 : Pedestal Installation 50
Appendix 3: Door Overlay Installation..... 52
Appendix 4: Decorative accent Installation 53
Appendix 5 : Optional Air Mate Installation..... 54
Appendix 6: Optional Fresh Air Intake Kit Installation 55
Appendix 7: Optional Fire Screen Installation..... 56
Appendix 8: optional Blower and thermodisc installation..... 57
Appendix 9: Air Tubes and Baffle Installation 58
Appendix 10: Exploded Diagram and Parts List 60
ENERZONE Limited Lifetime Warranty 63

Dealer:	_____
Installer:	_____
Phone Number:	_____
Serial Number:	_____

CERTIFICATION PLATE

ENGLISH

REFER TO INTERTEK'S DIRECTORY OF BUILDING PRODUCTS FOR DETAILED INFORMATION
SE RÉFÉRER AU RÉPERTOIRE DES PRODUITS HOMOLOGUÉS D'INTERTEK POUR PLUS D'INFORMATION

LISTED SOLID FUEL BURNING APPLIANCE
POÈLE À COMBUSTIBLE SOLIDE HOMOLOGUÉ

MODEL / MODÈLE : SOLUTION 2.3

Serial Number / No. de Série: **999996**



Intertek

Certified to/Certifié selon ULC S627
Certified to/Certifié selon UL 1482
Certified to/Certifié selon UL 737
CSA B415.1-10
March/Mars 2018
Control number: 4002461

Clearances to combustibles / Dégagements aux combustibles



DOOR OPENING
OUVERTURE DE PORTE

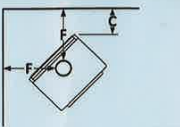

MOBILE HOME MAISONS MOBILES
Double wall connector
Tuyau à paroi double

A: 11 in./po. (279 mm)	G: 8 in./po. (203 mm) CANADA
B: 18 in./po. (457 mm)	H: 8 in./po. (203 mm) CANADA
C: 11 in./po. (279 mm)	I: 18 in./po. (457 mm) CANADA
D: 14.25 in./po. (362 mm)	J: 8 in./po. (203 mm) USA
E: 27.25 in./po. (692 mm)	K: 48 in./po. (1219 mm)
F: 20.5 in./po. (521 mm)	

Protection de plancher
Back / Arrière

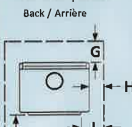

CANADA

Single wall connector Tuyau à paroi simple	Double wall connector Tuyau à paroi double
A: 14.5 in./po. (368 mm)	A: 6 in./po. (152 mm)
B: 17 in./po. (432 mm)	B: 17 in./po. (432 mm)
C: 10 in./po. (254 mm)	C: 7 in./po. (178 mm)
D: 18 in./po. (457 mm)	D: 9.25 in./po. (235 mm)
E: 26.5 in./po. (673 mm)	E: 26.25 in./po. (667 mm)
F: 19.75 in./po. (502 mm)	F: 16.5 in./po. (419 mm)

U.S.A.

Single wall connector Tuyau à paroi simple	Double wall connector Tuyau à paroi double
A: 11 in./po. (279 mm)	A: 6 in./po. (152 mm)
B: 16 in./po. (406 mm)	B: 16 in./po. (406 mm)
C: 10 in./po. (254 mm)	C: 7 in./po. (178 mm)
D: 14.5 in./po. (368 mm)	D: 9.25 in./po. (235 mm)
E: 25.5 in./po. (673 mm)	E: 25.25 in./po. (641 mm)
F: 19.75 in./po. (502 mm)	F: 16.5 in./po. (419 mm)

PREVENT HOUSE FIRES

- Install and use only in accordance with the manufacturer's installation and operating instructions.
- Contact local building or fire officials about restrictions and installation inspection in your area.
- Use listed 152 mm / 6 in. diameter single or double wall connectors with prefabricated chimneys approved UL 103 HT (US) and ULC S629 (CAN) suitable for solid fuels or lined masonry chimneys.
- See local building code and manufacturer's instructions for precautions required for passing a chimney through a combustible wall or ceiling.
- Do not pass connector through combustible wall or ceiling.
- Do not connect this unit to a chimney serving another appliance.
- Use with wood only. Do not use other fuels.
- Operate only with door closed or door open with firescreen installed. Open door or remove firescreen to feed the stove only.
- Do not obstruct the space underneath the stove.
- Do not use grate or elevate fire. Build fire directly on hearth.
- Do not overfire. If heater or chimney connector glows, you are overfiring.
- Inspect and clean chimney frequently. Under certain condition of use, creosote buildup may occur rapidly.
- Replace glass with ceramic type only.
- Install unit on a non-combustible material extending as shown above on this label.
- Suitable for mobile-home installation. Floor protection may vary from pedestal to legs version refer to owner's manual.
- Combustion air openings shall not be obstructed.
- This wood heater needs periodic inspection and repair for proper operation. Consult the owner's manual for further information. It is against US federal regulations to operate this wood heater in a manner inconsistent with the operating instructions in the owner's manual.

PREVENEZ LES INCENDIES

- Installer et utiliser conformément au manuel d'utilisation du fabricant.
- Contactez les autorités de votre localité ayant juridiction concernant les restrictions et inspections d'installation.
- Utiliser des tuyaux d'évacuation à parois simple ou double homologués d'un diamètre de 6 po. (152 mm) avec une cheminée préfabriquée approuvée UL 103 HT (US) et ULC S629 (CAN) pour utilisation au bois ou une cheminée de maçonnerie gainée.
- Voir les codes locaux et le manuel d'installation du fabricant pour le passage de la cheminée à travers un mur ou un plafond combustible.
- Ne pas traverser un plafond ou un mur combustible avec un tuyau d'évacuation.
- Ne pas raccorder cet appareil à une cheminée desservant un autre appareil.
- Brûler du bois seulement. Ne pas utiliser d'autres combustibles.
- Garder la porte fermée ou le pare-étincelle en place en tout temps. Ouvrir la porte ou retirer le pare-étincelle que lors du chargement.
- Ne rien entreposer sous l'appareil.
- Ne pas utiliser de grilles ou de chenets pour surélever le feu. Préparer le feu directement sur l'âtre.
- Ne pas surchauffer. Si l'appareil ou le tuyau rougit, il y a surchauffe.
- Inspecter et nettoyer la cheminée fréquemment. Sous certaines conditions, l'accumulation de créosote peut être rapide.
- Remplacer la vitre seulement avec un verre de céramique.
- Installer l'appareil sur une plaque non combustible tel qu'indiqué sur l'étiquette.
- Poêle approuvée pour maison mobile. La protection de plancher peut varier entre la version plédestal et sur pattes. Voir le manuel d'instructions.
- Les entrées d'air servant à la combustion ne doivent pas être obstruées.
- Cet appareil de chauffage requiert des inspections et réparations périodiques. Consulter le manuel de l'utilisateur pour plus d'information. Opérer cet appareil de chauffage de façon incohérente par rapport au manuel de l'utilisateur consiste une violation de la loi fédérale (USA).

Optional blower: (115V, 0.8A, 60Hz) Option ventilateur: (115V, 0.8A, 60Hz)

U.S. ENVIRONMENTAL PROTECTION AGENCY Certified to comply with 2020 particulate emission standards using cordwood.
AGENCE DE PROTECTION DE L'ENVIRONNEMENT DES E.-U. Conforme aux normes d'émission de particules de 2020 avec bûche de bois.

Weighted average emission rate / Moyenne pondérée des émissions : 1.54 g/h
When tested in accordance with/Lorsque testé selon ASTM E2515
Tested and certified in compliance with CFR 40 part 60, subpart AAA, section 60.534(a)(1)(ii) and Draft ASTM WK47329-14

WARNING: This product can expose you to carbon monoxide, which is known to the State of California to cause cancer, birth defects or other reproductive harm.
(For more information go to www.p65warnings.ca.gov)



CAUTION

- HOT WHILE IN OPERATION.
- DO NOT TOUCH. KEEP CHILDREN, CLOTHING AND FURNITURE AWAY.
- CONTACT MAY CAUSE SKIN BURNS. SEE NAME-PLATE AND INSTRUCTIONS.

ATTENTION

- CHAUD EN FONCTIONNEMENT.
- NE PAS TOUCHER. GARDER LES ENFANTS, LES VÊTEMENTS ET LES MEUBLES ÉLOIGNÉS.
- UN CONTACT AVEC LA PEAU PEUT OCCASIONNER DES BRÛLURES. VOIR LES INSTRUCTIONS.

Made in St-Augustin-de-Desmaures (Qc), Canada
10/10/2018 (# TEST)



Fabricant de poêles international
Stove Builder International

Fabriqué à St-Augustin-de-Desmaures (Qc), Canada
10/10/2018 (# TEST)

27716

PART A - OPERATION AND MAINTENANCE

1. Safety Information

- Operate only with the door fully closed or fully open with the fire screen in place. If the door is left partly open, gas and flame may be drawn out of the opening, creating risks from both fire and smoke.
- **HOT WHILE IN OPERATION, KEEP CHILDREN, CLOTHING AND FURNITURE AWAY. CONTACT MAY CAUSE SKIN BURNS. GLOVES MAY BE NEEDED FOR STOVE OPERATION.**
- Using a stove with cracked or broken components, such as glass, firebricks or baffle may produce an unsafe condition and may damage the stove.
- Open the air control fully before opening the loading door.
- This stove has been tested for use with an open door in conjunction with a fire screen, sold separately. The door may be open, or fire screen removed only during lighting procedures or reloading. Always close the door or put back the fire screen after ignition. Do not leave the stove unattended when the door is opened with or without the fire screen.
- **NEVER USE GASOLINE, LANTERN FUEL (NAPHTHA), FUEL OIL, MOTOR OIL, KEROSENE, CHARCOAL LIGHTER FLUID, OR SIMILAR LIQUIDS OR AEROSOLS TO START A FIRE IN THIS STOVE. KEEP ALL SUCH LIQUIDS OR AEROSOLS WELL AWAY FROM THE STOVE WHILE IT IS IN USE.**
- Do not store fuel within heater minimum installation clearances.
- Burn only seasoned natural firewood.
- This wood heater needs periodic inspection and repair for proper operation. It is against federal regulations to operate this wood heater in a manner inconsistent with operating instructions in this manual.
- This appliance should always be maintained and operated in accordance with these instructions.
- Do not elevate the fire by using a grate.
- A smoke detector, a carbon monoxide detector and a fire extinguisher should be installed in the house. The location of the fire extinguisher should be known by all family members.



This product can expose you to chemicals including carbon monoxide, which is known to the State of California to cause cancer, birth defects or other reproductive harm. For more information go to www.P65warnings.ca.gov/

2. General Information

2.1 Performances

Values are as measured per test method, except for the recommended heating area, firebox volume, maximum burn time and maximum heat output.

ENGLISH

Model	Solution 2.3 (EB00041)	
Fuel Type	Dry Cordwood	
Recommended heating area (sq. ft.) ¹	500 to 2,100 ft ² (47 to 195 m ²)	
Nominal firebox volume	2.4 ft ³ (0.068 m ³)	
Maximum burn time ¹	8 hours	
Maximum heat output (dry cordwood) ²	75,000 BTU/h (22.0 kW)	
Overall heat output rate (min. to max.) ^{2 3}	14,800 BTU/h to 28,600 BTU/h (4.34 kW to 8.38 kW)	
Average overall efficiency ³ Dry cordwood	69 % (HHV) ⁴	74 % (LHV) ⁵
Optimum efficiency ⁶	77 %	
Average particulate emissions rate ⁷	1.54 g/h (EPA / CSA B415.1-10) ⁸	
Average CO ⁹	89.4 g/h	

¹ Recommended heating area and maximum burn time may vary subject to location in home, chimney draft, heat loss factors, climate, fuel type, feed rate, fuel level, and other variables. The recommended heated area for a given appliance is defined by the manufacturer as its capacity to maintain a minimum acceptable temperature considering that the space configuration and the presence of heat distribution systems have a significant impact in making heat circulation optimum.

² The maximum heat output (dry cordwood) is based on a loading density varying between 15 lb/ft³ and 20 lb/ft³. Other performances are based on a fuel load prescribed by the standard. The specified loading density varies between 7 lb/ft³ and 12 lb/ft³. The moisture content is between 19% and 25%.

³ As measured per CSA B415.1-10 stack loss method.

⁴ Higher Heating Value of the fuel.

⁵ Lower Heating Value of the fuel.

⁶ Optimum overall efficiency at a specific burn rate (LHV).

⁷ This appliance is officially tested and certified by an independent agency.

⁸ Tested and certified in compliance with CFR 40 part 60, subpart AAA, section 60.534(a)(1)(ii) and Draft ASTM WK47329-14.

⁹ Carbon monoxide.

2.2 Specifications

Maximum log length ¹	20 in (508 mm) east-west
Flue outlet diameter	6 in (150 mm)
Recommended connector pipe diameter	6 in (150 mm)
Type of chimney	ULC S629, UL 103 HT (2100 °F)
Baffle material	C-Cast
Approved for alcove installation	Yes
Approved for mobile home installation ²	Yes
Shipping weight (without option)	375 lb (170 kg)
Appliance weight (model with legs)	353 lb (160 kg)
Appliance weight (model with pedestal)	365 lb (166 kg)
Type of door	Simple, glass with cast iron frame
Type of glass	Ceramic glass
Blower	Optional (up to 130 CFM)
Particulate emission standard	EPA / CSA B415.1-10 ³
USA standard (Safety)	UL 1482, UL 737
Canada standard (Safety)	ULC S627

¹East-west: through the door you see the longitudinal sides of the logs; north-south: through the door you see the tips of the logs.

² Mobile home (Canada) or manufactured home (USA): The US department of Housing and Urban Development describes “manufactured homes” better known as “mobile homes” as followed; buildings built on fixed wheels and those transported on temporary wheels/axles and set on a permanent foundation. In Canada, a mobile home is a dwelling for which the manufacture and assembly of each component is completed or substantially completed prior to being moved to a site for installation on a foundation and connection to service facilities and which conforms to the CAN/CSA-Z240 MH standard.

³ Tested and certified in compliance with CFR 40 part 60, subpart AAA, section 60.534(a)(1(ii) and Draft ASTM WK47329-14.

2.3 Dimensions

2.3.1 Stove Dimensions With Leg Kit AC01206 or AC01208

ENGLISH

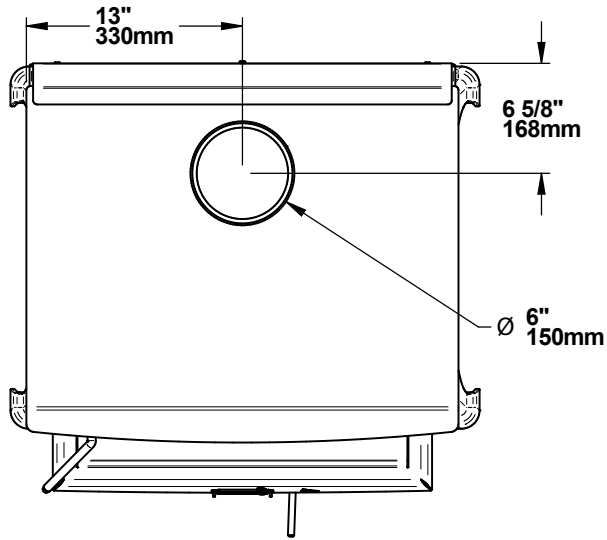

Figure 1: Top view

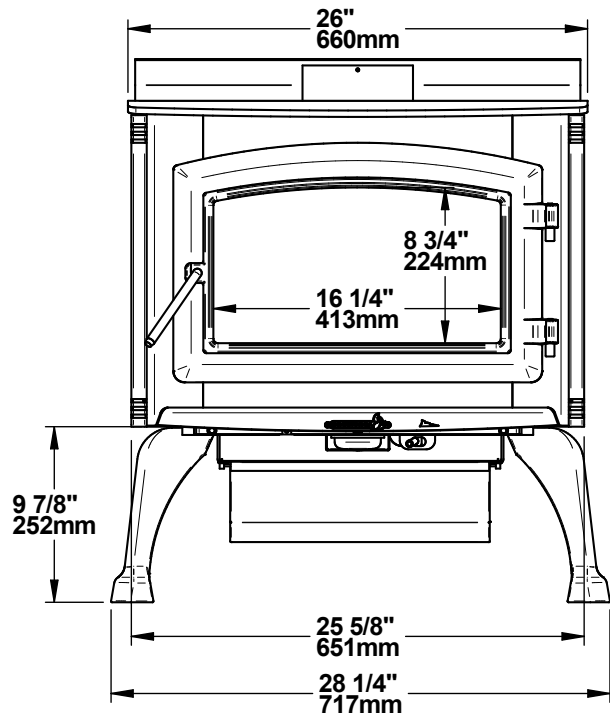

Figure 2: Front view

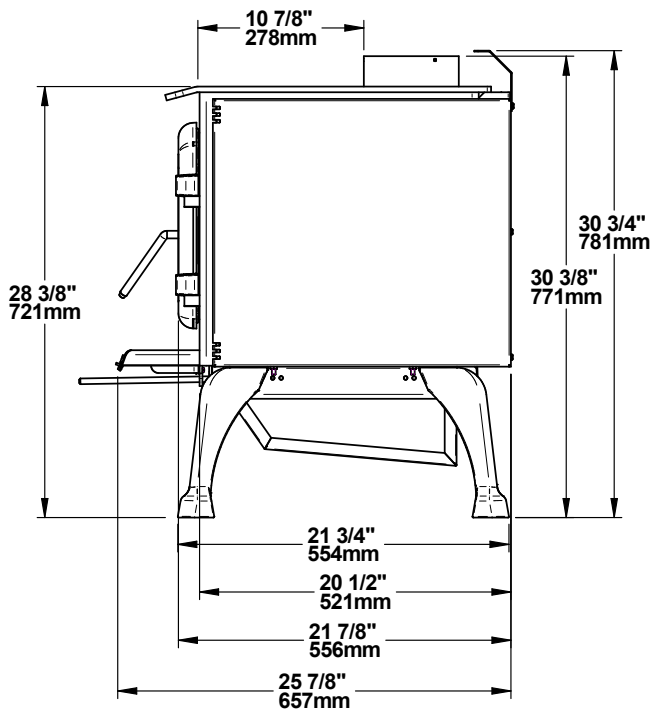

Figure 3: Side view

2.3.2 Stove Dimensions With Leg Kit AC01293 or AC01294

ENGLISH

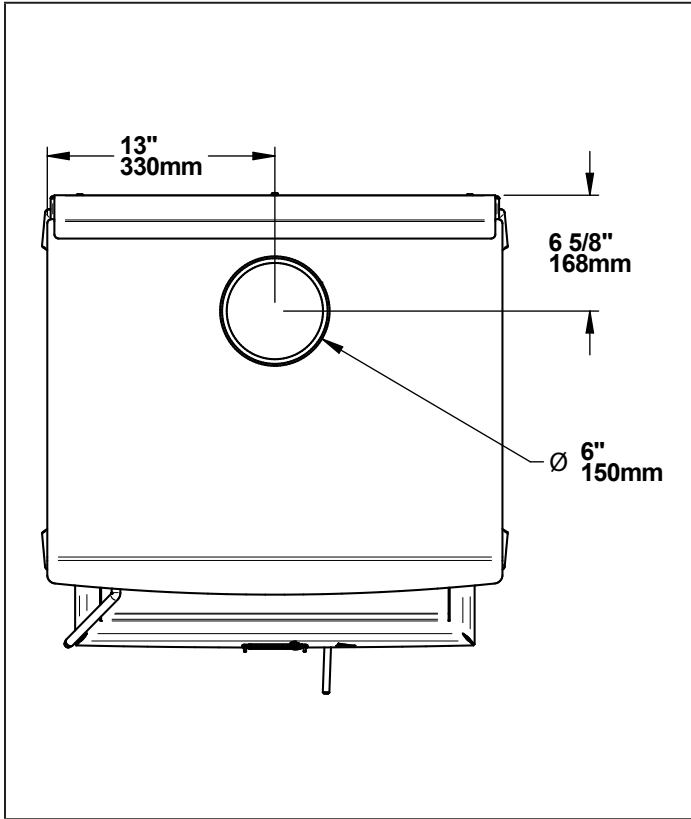

Figure 4: Top view

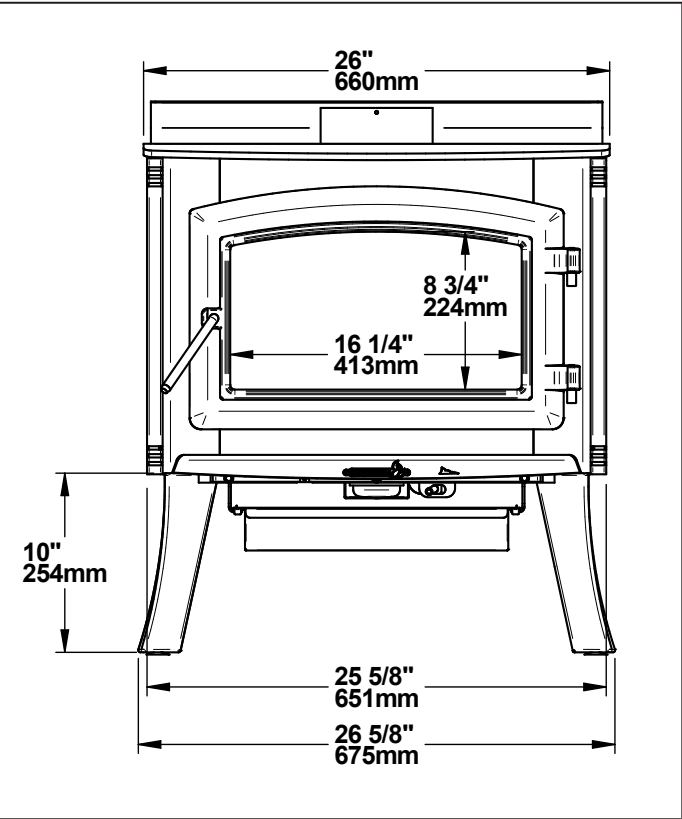

Figure 5: Front view

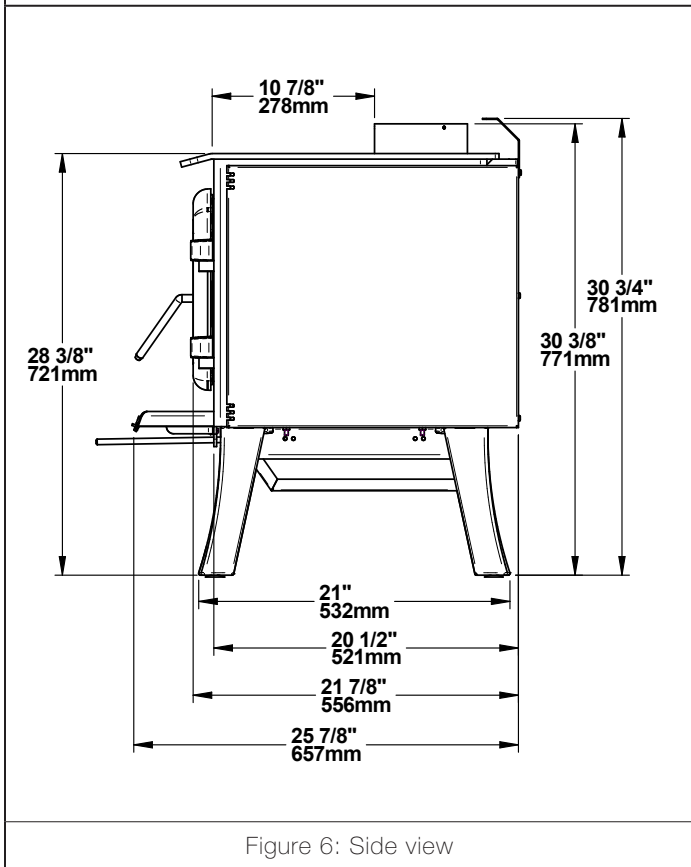

Figure 6: Side view

2.3.3 Stove Dimensions With Leg Kit AC01295 or AC01296

ENGLISH

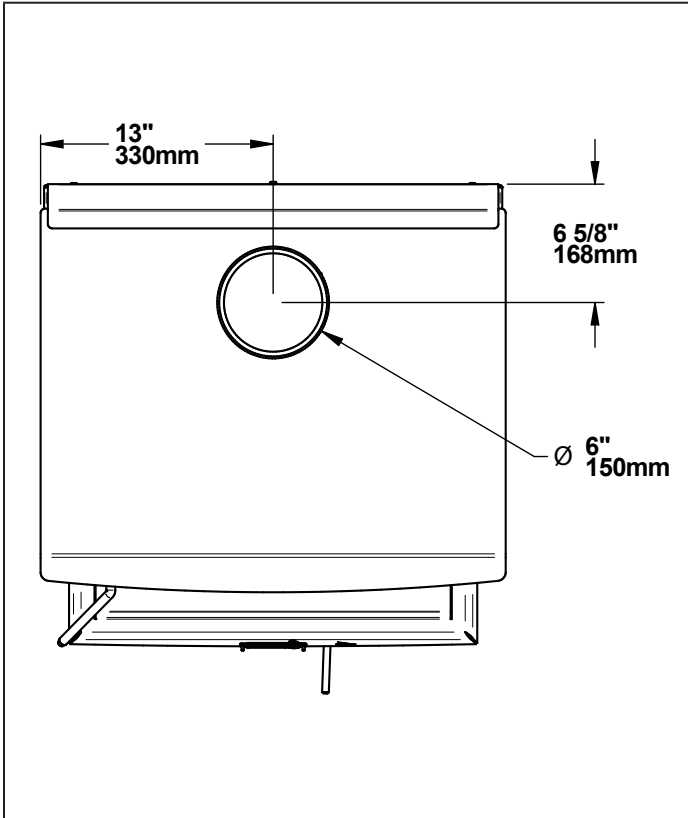

Figure 7: Top view

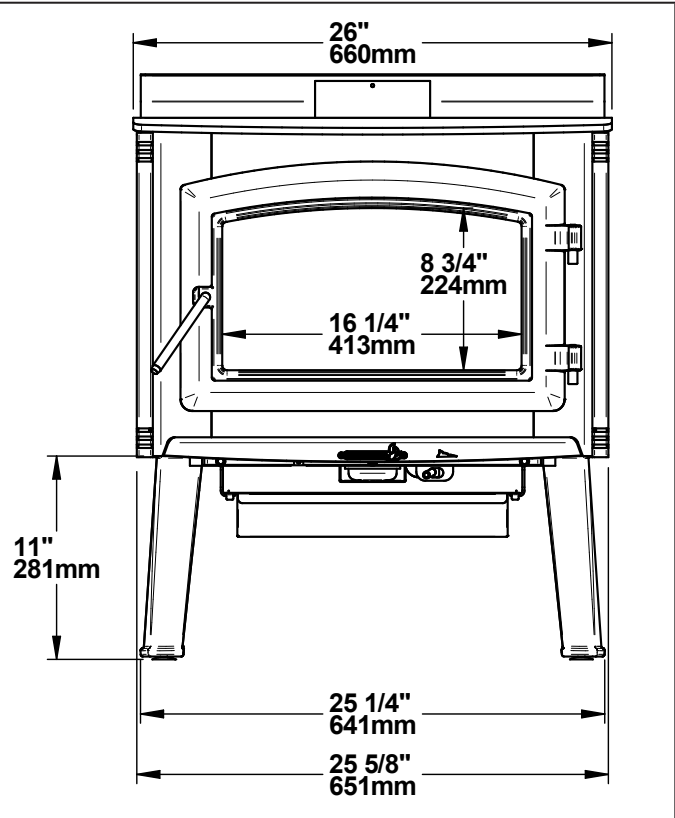

Figure 8: Front view

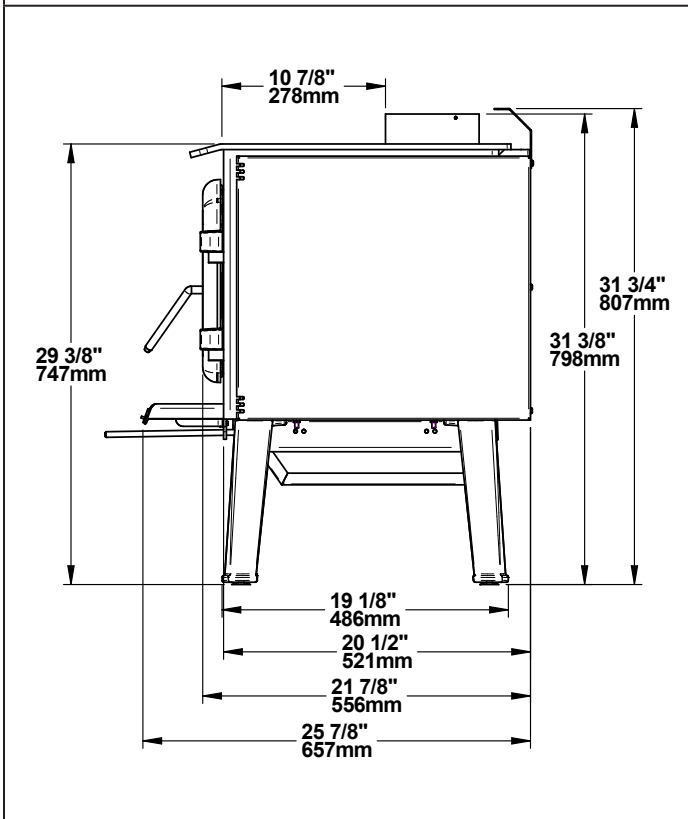

Figure 9: Side view

2.3.4 Stove Dimensions With Pedestal

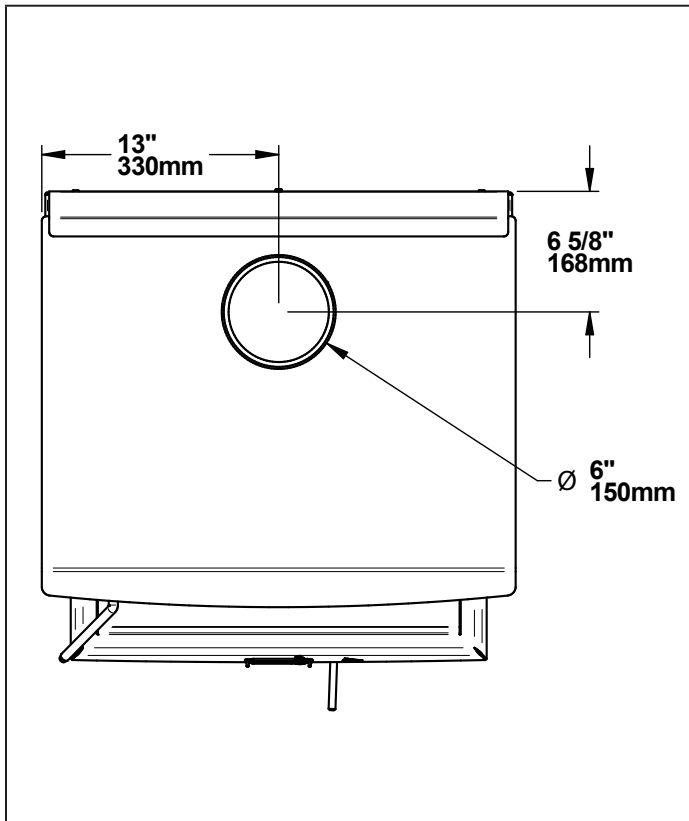

Figure 10: Top view

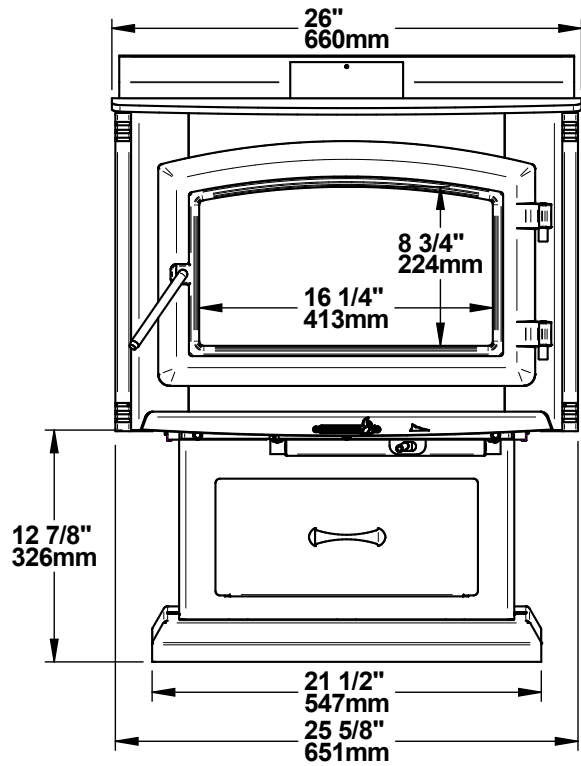

Figure 11: Front view

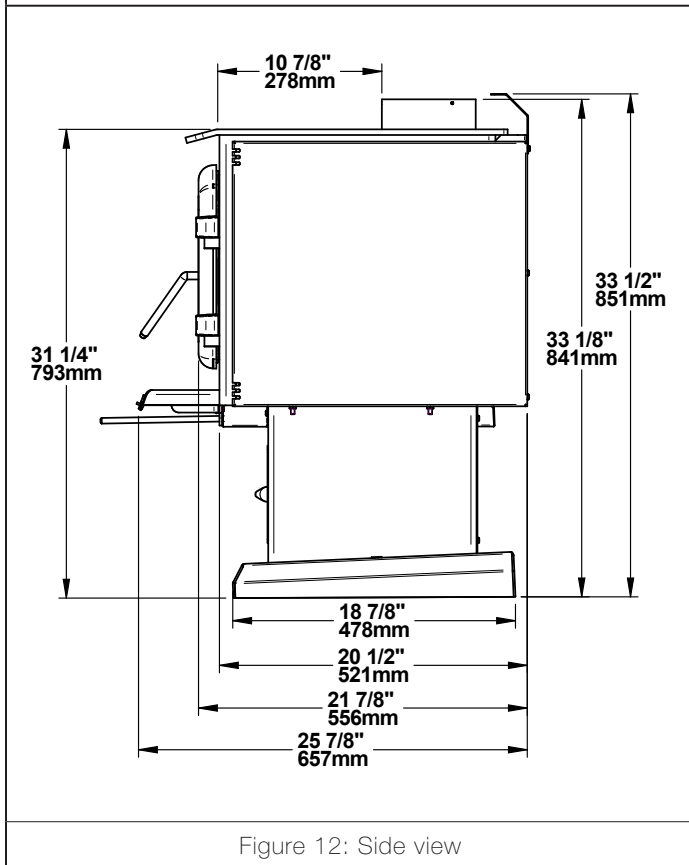

Figure 12: Side view

2.3.5 Combustion Chamber Dimensions

ENGLISH

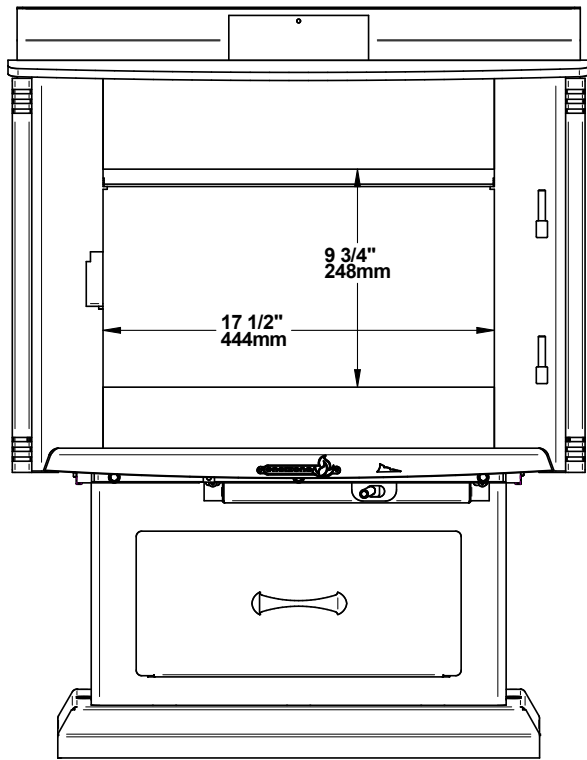

Figure 13: Door opening

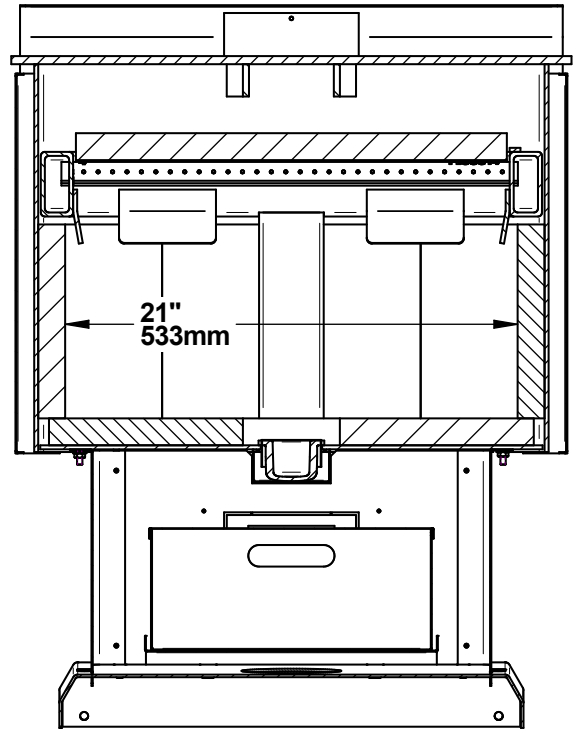

Figure 14: Front view - Combustion chamber

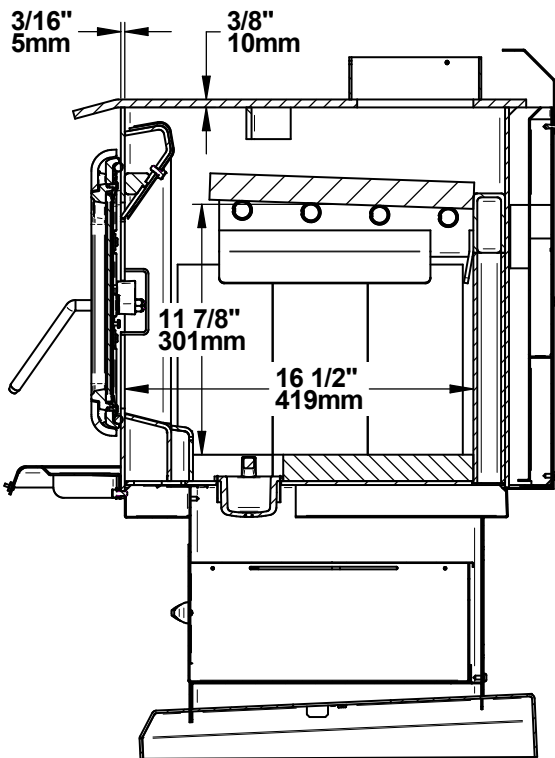

Figure 15: Side view - Combustion chamber

2.4 Zone Heating and How to Make it Work for You

This stove is a space heater, which means it is intended to heat the area it is installed in, as well as spaces that connect to that area, although to a lower temperature. This is called zone heating and it is an increasingly popular way to heat homes or spaces within homes.

Zone heating can be used to supplement another heating system by heating a particular space within a home, such as a basement, a family room or an addition that lacks another heat source.

Houses of moderate size and relatively new construction can be heated with a properly sized and located wood stove. Whole house zone heating works best when the stove is in the part of the house where the family spends most of its time. This is normally the main living area where the kitchen, dining and living rooms are located. Locating the stove in this area will give the maximum benefit of the heat it produces and will achieve the highest possible heating efficiency and comfort. The space where the most time is spent will be warmest, while bedrooms and basement (if there is one) will stay cooler. In this way, less wood is burnt than with other forms of heating.

Although the stove may be able to heat the main living areas of the house to an adequate temperature, it is strongly recommend to also have a conventional oil, gas or electric heating system to provide backup heating.

The success of zone heating will depend on several factors, including the correct sizing and location of the stove, the size, layout and age of your home and your climate zone. Three-season vacation homes can usually be heated with smaller stoves than houses that are heated all winter.

2.5 The Benefits of Low Emissions and High Efficiency

The low smoke emissions produced by the special features inside this stove firebox mean that the household will release up to 90% less smoke into the outside environment than if an older conventional stove was used. But there is more to the emission control technologies than protecting the environment.

The smoke released from wood when it is heated contains about half of the energy content of the fuel. By burning the wood completely, this stove releases all the heat energy from the wood instead of wasting it as smoke up the chimney. Also, the features inside the firebox allows control of the air supply meaning controlling the heat output, while maintaining clean and efficient flaming combustion, which boosts the efficient delivery of heat to the home.

The emission control and advanced combustion features of this stove can only work properly if the fuel used is in the correct moisture content range of 15% to 20%. See section [«3. Fuel»](#) of this manual for suggestions on preparing fuelwood and judging its moisture.

2.6 The SBI Commitment to You and the Environment

The SBI team is committed to protecting the environment, so we do everything we can to use only materials in our products that will have no lasting negative impact on the environment.

2.6.1 What is This Stove Made Of?

The **body** of this stove, which is most of its weight, is carbon steel. Should it ever become necessary many years in the future, almost the entire stove can be recycled into new products, thus eliminating the need to mine new materials.

The **paint** coating on the stove is very thin. Its VOC content (Volatile Organic Compounds) is very low. VOCs can be responsible for smog, so all the paint used during the manufacturing process meets the latest air quality requirements regarding VOC reduction or elimination.

The **air tubes** are stainless steel, which can also be recycled.

The C-Cast **baffle** is made of an aluminosilicate fibre material that is compressed with a binder to form a rigid board. C-Cast can withstand temperatures above 2,000 °F. It is not considered hazardous waste. Disposal at a landfill is recommended.

Firebrick is mainly composed of silicon dioxide, also known as silica, a product processed from a mined mineral. It is most commonly found in nature in the form of sand and clay. Disposal at a landfill is recommended.

The door and glass **gaskets** are fibreglass which is spun from melted sand. Black gaskets have been dipped into a solvent-free solution. Disposal at a landfill is recommended.

The door **glass** is a 4 mm thick ceramic material that contains no toxic chemicals. It is made of natural raw materials such as sand and quartz that are combined in such a way to form a high temperature glass. Ceramic glass cannot be recycled in the same way as normal glass, so it should not be disposed of with your regular household products. Disposal at a landfill is recommended.

3. Fuel

MATERIALS THAT SHOULD NOT BE BURNED

- **GARBAGE;**
- **LAWN CLIPPINGS OR YARD WASTE;**
- **MATERIALS CONTAINING RUBBER, INCLUDING TIRES;**
- **MATERIALS CONTAINING PLASTIC;**
- **WASTE PETROLEUM PRODUCTS, PAINTS OR PAINT THINNERS, OR ASPHALT PRODUCTS;**
- **MATERIALS CONTAINING ASBESTOS;**
- **CONSTRUCTION OR DEMOLITION DEBRIS;**
- **RAILROAD TIES OR PRESSURE-TREATED WOOD;**
- **MANURE OR ANIMAL REMAINS;**
- **SALT WATER DRIFTWOOD OR OTHER PREVIOUSLY SALT WATER SATURATED MATERIALS;**
- **UNSEASONED WOOD; OR**
- **PAPER PRODUCTS, CARDBOARD, PLYWOOD, OR PARTICLEBOARD. THE PROHIBITION AGAINST BURNING THESE MATERIALS DOES NOT PROHIBIT THE USE OF FIRE STARTERS MADE FROM PAPER, CARDBOARD, SAW DUST, WAX AND SIMILAR SUBSTANCES FOR THE PURPOSE OF STARTING A FIRE IN AN AFFECTED WOOD HEATER.**

BURNING THESE MATERIALS MAY RESULT IN RELEASE OF TOXIC FUMES OR RENDER THE HEATER INEFFECTIVE AND CAUSE SMOKE.

3.1 How to Prepare or Buy Good Firewood

3.1.1 What is Good Firewood?

Good firewood has been cut to the correct length for the stove, split to a range of sizes and stacked in the open until its moisture content is down to 15% to 20%.

3.1.2 Tree Species

The tree species the firewood is produced from is less important than its moisture content. The main difference in firewood from various tree species is the density of the wood. Hardwoods are denser than softwoods. People who live in the coldest regions of North America usually have only spruce, birch and poplar, other low-density species to burn and yet they can heat their homes successfully.

Homeowners with access to both hardwood and softwood sometimes use both types for different purposes. For example, softer woods make good fuel for mild weather in spring and fall because they light quickly and produce less heat. Softwoods are not as dense as hardwoods so a given volume of wood contains less energy. Using softwoods avoids overheating the house, which can be a common problem with wood heating in moderate weather. Harder woods are best for colder winter weather when more heat and longer burn cycles are desirable.

Note that hardwood trees like oak, maple, ash and beech are slower growing and longer lived than softer woods like poplar and birch. That makes hardwood trees more valuable. The advice that only hardwoods are good to burn is outdated. Old, leaky cast iron stoves wouldn't hold a fire overnight unless they were fed large pieces of hardwood. That is no longer true. It is possible to successfully heat a home by using the less desirable tree species and give the forest a break at the same time.

3.1.3 Log Length

Logs should be cut at least 1" (25 mm) shorter than the firebox so they fit in easily. Pieces that are even slightly too long make loading the stove very difficult. The most common standard length of firewood is 16" (400 mm).

The pieces should be a consistent length, with a maximum of 1" (25 mm) variation from piece to piece.

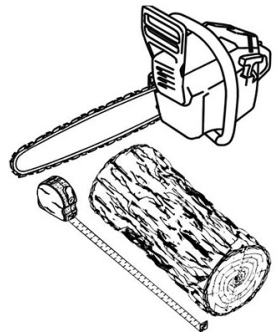

3.1.4 Piece Size

Firewood dries more quickly when it is split. Large unsplit rounds can take years to dry enough to burn. Even when dried, unsplit logs are difficult to ignite because they don't have the sharp edges where the flames first catch. Logs as small as 3" (75 mm) should be split to encourage drying.

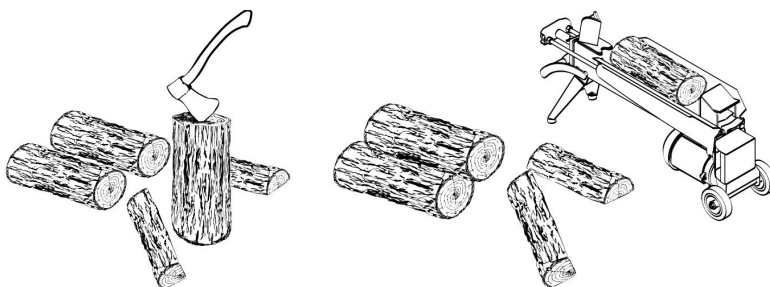

Wood should be split to a range of sizes, from about 3" to 6" (75 mm to 150 mm) in cross section. Having a range of sizes makes starting and rekindling fires much easier. Often, the firewood purchased from commercial suppliers is not split small enough to fuel the fire. It is sometimes advisable to resplit the wood before stacking to air dry.

3.1.5 How to Dry Firewood

Firewood that is not dry enough to burn is the cause of most complaints about wood stoves. Continually burning green or unseasoned wood produces more creosote and involves lack of heat and dirty glass door.

Here are some things to consider in estimating drying time:

- Firewood takes a long time to dry;
- Firewood bought from a dealer is rarely dry enough to burn, so it is advisable to buy the wood in spring and dry it yourself;
- Drying happens faster in dry weather than in damp, maritime climates;
- Drying happens faster in warm summer weather than in winter weather;
- Small pieces dry more quickly than large pieces;
- Split pieces dry more quickly than unsplit rounds;
- Softwoods take less time to dry than hardwoods;
- Softwoods like pine, spruce, poplar, and aspen can be dry enough to burn after being stacked to air dry only for the summer months;
- Hardwoods like oak, maple and ash can take one, or even two years to dry fully, especially if the pieces are big;
- Firewood dries more quickly when stacked outside in a location exposed to sun and wind; it takes much longer to dry when stacked in a wood shed;
- Firewood that is ready to burn has a moisture content between 15% and 20% and will allow the stove to produce its highest possible efficiency.

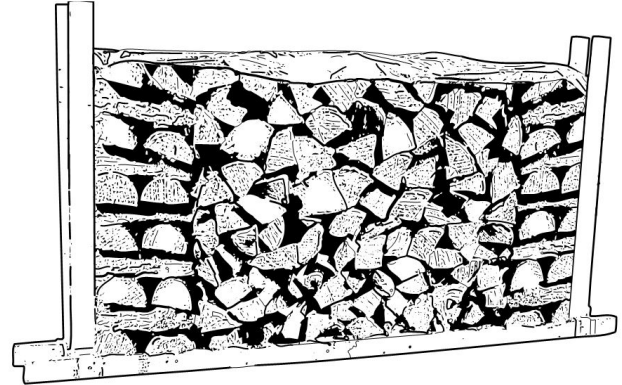

3.1.6 Judging Firewood Moisture Content

Use these guidelines to find out if the firewood is dry enough to burn:

- Cracks form at the ends of logs as they dry,
- As it dries in the sun, the wood turns from white or cream colored to grey or yellow,
- Bang two pieces of wood together; seasoned wood sounds hollow and wet wood sounds dull,
- Dry wood is much lighter in weight than wet wood,
- Split a piece, and if the fresh face feels warm and dry it is dry enough to burn; if it feels damp, it is too wet,
- Burn a piece; wet wood hisses and sizzles in the fire and dry wood does not.
- A wood moisture meter can be bought to test the firewood.

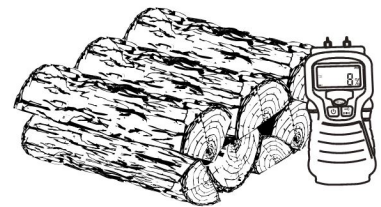

3.1.7 Manufactured Logs

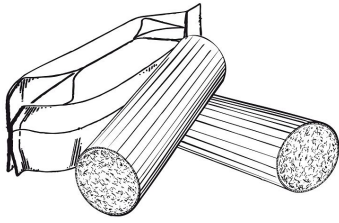

Do not burn manufactured logs made of wax impregnated sawdust or logs with any chemical additives. Manufactured logs made of 100% compressed sawdust can be burned with caution in the number of these logs burned at one time. Start with one manufactured log and see how the stove reacts. Never use more than two manufactured logs.

4. Operating Your Stove

This wood heater has a manufacturer-set minimum low burn rate that must not be altered. It is against federal regulations to alter this setting or otherwise operate this wood heater in a manner inconsistent with operating instructions in this manual.

4.1 Before Operating Your Stove

Before using the stove, the following items should be installed :

- The pedestal or the leg kit (see [«Appendix 1 : Legs Installation»](#), page 47, or [«Appendix 2 : Pedestal Installation»](#), page 50)
- The decorative accents (see [«Appendix 4: Decorative accent Installation»](#), page 53),
- The door overlay (see [«Appendix 3: Door Overlay Installation»](#), page 52),
- The door coil handle **(A)** and the air control coil handle **(B)** .

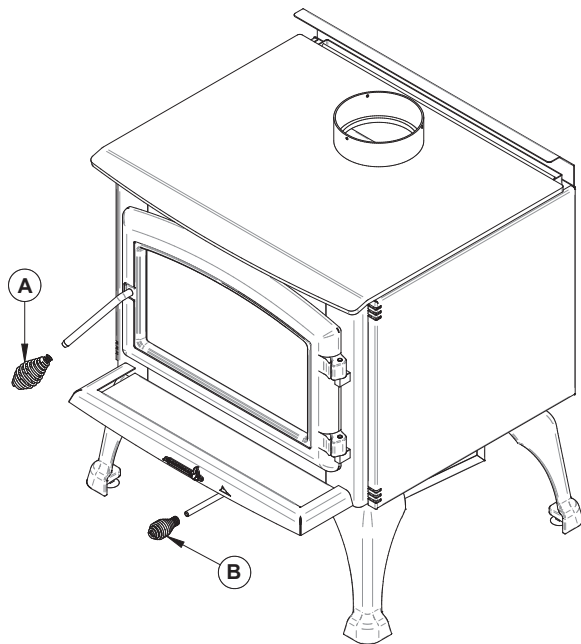

Figure 16: Installing the coil handles

4.2 The Use of a Fire Screen

This stove has been tested for use with an open door in conjunction with a fire screen, sold separately. The fire screen must be properly secured on the stove to avoid any risk of sparks damaging the flooring. When the fire screen is in use, do not leave the stove unattended to respond promptly in the event of smoke spillage into the room.

Potential causes of smoke spillage are described in Section [«8. The Venting System»](#) of this manual. See [«Appendix 7: Optional Fire Screen Installation»](#) for installation instructions.

OPERATING THE STOVE WITH A FIRE SCREEN INCREASES POSSIBILITIES OF GENERATING CARBON MONOXIDE. CARBON MONOXIDE IS AN ODOURLESS GAS THAT IS HIGHLY TOXIC WHICH CAN CAUSE DEATH AT HIGH CONCENTRATION IN AIR.

Blower Operation

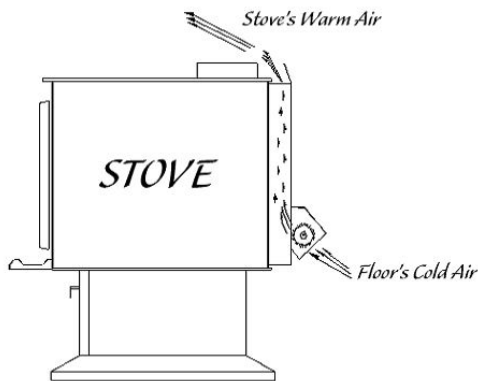

Figure 17: Air flow with a blower

It is possible to install a blower on this stove. The blower is optional and is sold separately. See [«Appendix 10: Exploded Diagram and Parts List»](#) for genuine part number.

The blower is installed on the back of the stove to increase airflow through the heat exchanger and improve hot air circulation in the room. When used regularly, the blower can provide a small increase in efficiency, up to 2%. However, the use of a blower should not be used as a way to gain more output from a stove that is undersized for the space it is intended to heat.

Ensure the blower cord is not in contact with any surface of the stove to prevent electrical shock or fire damage. Do not run cord beneath the stove.

The blower has a rheostat that can be adjusted in three different positions; either from high (HI) to low (LO) or closed (OFF).

Allow the stove to reach operating temperature (approximately one hour) before turning on the blower, since increased airflow from the blower will remove heat and affect the start up combustion efficiency.

The blower is also equipped with a heat sensor. When the blower is ON, it will start automatically when the stove is hot enough and it will stop when the stove has cooled down. Therefore, the blower speed control can be left at the desired setting.

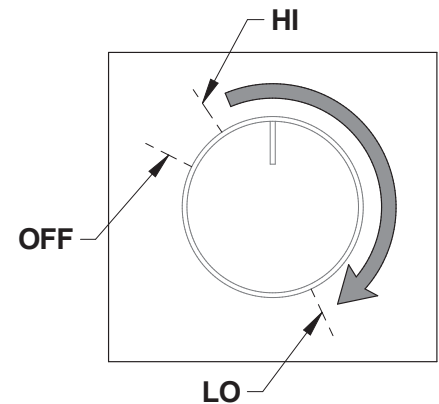

Figure 18: Blower rheostat

4.3 The First Fires

Two things will happen when burning the first few fires; the paint cures and the internal components of the stove are conditioned.

As the paint cures, some of the chemicals vaporize. The vapors are not poisonous, but they do smell bad. Fresh paint fumes can also cause false alarms in smoke detectors.

So, when lighting the stove, be prepared by opening doors or windows to ventilate the house. Burn one or two small fires to begin the curing and conditioning process. Then build bigger and hotter fires until there is no longer paint smell from the stove.

As hotter and hotter fires are burnt, more of the painted surfaces reach the curing temperature of the paint. The smell of curing paint does not disappear until one or two very hot fires have been burnt.

4.4 Lighting Fires

Each person heating with wood develops its own favorite way to light fires. Whichever method is chosen, the goal should be to get a hot fire burning, quickly. A fire who ignites fast produces less smoke and deposits less creosote in the chimney. Here are three popular and effective ways to ignite wood fires.

4.4.1 Conventional Method

The conventional method to build a wood fire is to bunch up 5 to 10 sheets of newspaper and place them in the firebox. Next, a dozen pieces of fine kindling are placed on the newspaper. This kindling should be very thin; less than 1 inch thick (25 mm). Then, larger kindling pieces are placed on the fine kindling. The air control fully open, the newspaper is lit. With a tall and straight venting system the door can be closed immediately and the fire will ignite. Once the fire has ignited, the door can be closed with the air control still fully open. When the kindling is almost completely burned, standard firewood pieces can be added until the fire is the right size for the weather.

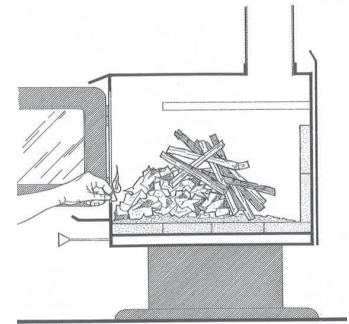

DO NOT LEAVE THE STOVE UNATTENDED WHEN THE DOOR IS SLIGHTLY OPENED. ALWAYS CLOSE AND LATCH THE DOOR AFTER THE FIRE IGNITES.

4.4.2 The Top Down Method

The top down method solves two problems encountered when using the conventional method: first, the fire does not collapse on itself and smother as it burns; and second, it is not necessary to build up the fire gradually since the firebox is loaded before the fire is lit. A top down fire can burn for two hours or more. The top down method works properly only if well-seasoned wood is used.

Three or four full-sized split pieces of dry firewood are placed in the firebox. Then, 4 or 5 more finely split pieces of firewood (2" to 3" [50 mm to 75 mm] in diameter) are placed on the top of the logs at right angles (log cabin style). Next, a dozen of finely split kindling are placed on the second layer at right angles.

The fire is topped with 5 sheets of newspaper, stuffed in between the kindling, under the baffle. Knots can be made in the newspaper by rolling up single sheets corner to corner and tying a knot in them. The advantage of knots is that they don't roll off the fire as they burn. Newspaper is lit and the fire burns from top to bottom.

4.4.3 Two Parallel Logs Method

Two spit logs are placed in the firebox with a few sheets of twisted newspaper in between the logs. Fine kindling is added across the two logs and some larger kindling across those, log cabin style. Newspaper is lit.

4.4.4 Using Fire Starters

Commercial fire starters can be used instead of newspaper. Some of these starters are made of sawdust and wax and others are made of specialized flammable solid chemicals. Always follow the package directions when using.

Gel starter can also be used, but only to light a fire, in a cold combustion chamber without hot embers inside.

DO NOT USE FLAMMABLE LIQUIDS SUCH AS GASOLINE, NAPHTHA, FUEL OIL, MOTOR OIL, OR AEROSOLS TO START OR REKINDLE THE FIRE.

4.5 Maintaining Wood Fires

4.5.1 General Advice

Wood heating with a space heater is very different than other forms of heating. There will be temperature variations in different parts of the house and there will be temperature variations throughout day and night. This is normal, and for experienced wood burners these are advantages of zone heating woodburning.

Wood stoves don't have a steady heat output. It is normal for the temperature to rise after a new load of wood is ignited and for its temperature to gradually decrease throughout the burning cycle. This increasing and decreasing temperature can be matched with the household routines. For example, the temperature in the area can be cooler when the household is active, and it can be warmer when it is inactive.

Wood burns best in cycles. A cycle starts when a new load of wood is ignited by hot coals and ends when that load has been consumed down to a bed of charcoal about the same size as it was when the wood was loaded. Trying to produce a steady heat output by placing a single log on the fire at regular intervals is not recommended. Always place at least three, and preferably more pieces on the fire at a time so that the heat radiated from one piece helps to ignite the pieces next to it. Each load of wood should provide several hours of heating. The size of each load may vary depending on the amount of heat required.

Burning in cycles means the stove door do not need to be opened while the wood is flaming. This is an advantage since it is preventing smoke leaking from the stove when the door is opened as a full fire is burning. This is especially true if the chimney is on the outside wall of the house.

If the door must be open while the fire is flaming, fully open the air control for a few minutes then open the door slowly. (See section «4.5.5 Controlling the Air Intake»)

4.5.2 Ash Removal

Ash should be removed from the firebox every two to three days of full time heating. Ash should not accumulate excessively in the firebox since it will affect the proper operation of the stove.

The best time to remove ash is in the morning, after an overnight fire when the stove is relatively cold, but there is still a little chimney draft to draw the ash dust into the stove and prevent going out into the room.

Ashes should be placed in a tightly covered metal container. The container must be placed on a non-combustible floor or on the ground well away from all combustible materials.

Ashes can contain hot embers that can stay hot for several days. If the ashes are disposed of by burial in soil or otherwise locally dispersed, they should be kept in the closed metal container until they are completely cooled. No other waste should be placed in this container.

NEVER STORE ASHES INDOORS OR IN A NON-METALIC CONTAINER OR ON A WOODEN DECK.

4.5.3 Raking Charcoal

When the room temperature is cooler, it is time to reload the stove. Remove the ashes first, then rake charcoal towards the front of the firebox before reloading. Most of the remaining charcoal will be at the back of the firebox, furthest from the door. Rake the coals towards the door before loading.

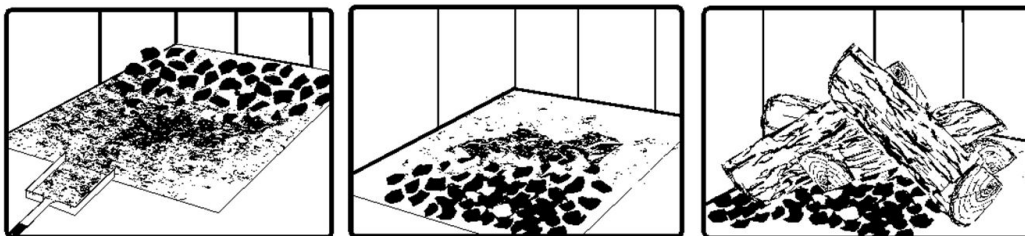

Raking the coals is useful for two reasons. First, it brings them near where most of the combustion air enters the firebox. This will ignite the new load quickly. Secondly, the charcoal will not be smothered by the new load of wood. When the embers are simply spread inside the combustion chamber, the new load smoulder for a long time before igniting.

4.5.4 Firing Each New Load Hot

Place the new load of wood on and behind the charcoal. Close the door and open the air control fully until the firebox is full of flames, the wood has charred to black and its edges are glowing red. Firing each load of wood hot accomplishes the following things:

- Removes surface moisture from the wood,
- Creates a layer of char on the wood, which slows down the smoke release,
- Heats the firebox components so they reflect heat back to the fire, and
- Heats the chimney so it can produce strong, steady draft for the rest of the cycle.

Although it is important to fire each new load hot, *do not allow the fire to burn at full intensity for more than a few minutes.*

THE STOVE SHOULD NOT BE LEFT UNATTENDED WHILE A NEW LOAD IS BEING FIRED HOT.

DO NOT OVERFIRE.

When a new load of wood is ignited, there will be a surge of heat from the stove. This heat surge is welcome when the room temperature is a little lower than desirable, but not welcome if the space is already warm. Therefore, each load of wood should burn completely so that the space begins to cool off a little before loading. Letting the space cool before loading is one of the secrets to clean burning and effective zone heating.

4.5.5 Controlling the Air Intake

Once the firewood, firebox and chimney are hot, air intake can be reduced to achieve a steady burn.

As the air intake is reduced, the burn rate decreases. This has the effect of distributing the thermal energy of the fuel over a longer period of time. In addition, the flow rate of exhaust through the stove and flue pipe slows down, which increases the duration of the energy transfer of the exhaust gases. As the air intake is reduced, the flames slow down.

If the flames diminish to the point of disappearing, the air intake has been reduced too early in the combustion cycle or the wood used is too wet. If the wood is dry and the air control is used properly, the flames should decrease, but remain bright and stable.

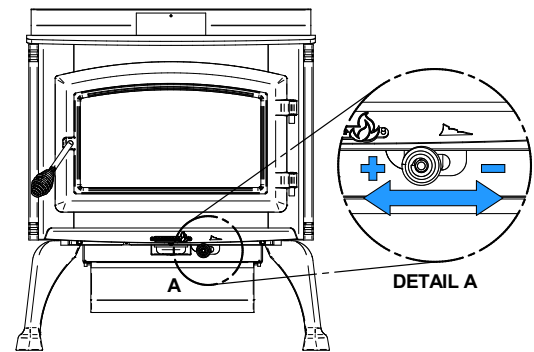

Figure 19: Air Intake Control

4.6 Building Different Fires for Different Needs

Using the air intake control is not the only way to match the stove heat output to the desired temperature in the house. A house will need far less heating in October than in January to maintain a comfortable temperature. Filling the firebox full in fall weather will overheat the space. Otherwise, the combustion rate will have to be reduced to a minimum and the fire will be smoky and inefficient. Here are some suggestions for building fires suitable for different heating needs.

4.6.1 Small Fires to Take the Chill Off the House

To build a small fire that will produce a low heat output, use small pieces of firewood and load them crisscross in the firebox. The pieces should only be 3" to 4" in diameter. After raking the coals, lay two pieces parallel to each other diagonally in the firebox and lay two more across them in the other direction. Open the air control fully and only reduce the air after the wood is fully flaming.

This kind of fire is good for mild weather and should provide enough heat for up to four hours. Small fires like this are a good time to use softer wood species and avoid overheating the house.

4.6.2 Long Lasting Low Output Fires

For a fire that will last up to eight hours but will not produce intense heat, use soft wood and place the logs compactly in the firebox. Before reducing the air intake, the load will have to burn at full heat for long enough for charring the surface of the logs. The flame must be bright before letting the fire burn by itself.

4.6.3 High Output Fires for Cold Weather

When heating needs are high during cold weather, the fire should burn steadily and brightly. This is the time to use larger pieces of hardwood. Place the biggest pieces at the back of the firebox and place the rest of the pieces compactly. A densely built fire like this will produce the longest combustion this stove is capable of.

Special attention must be paid when building fires like this since if the air intake is reduced too quickly, the fire could smoulder. The wood must be flaming brightly before leaving the fire to burn.

4.6.4 Maximum Burn Cycle Times

The burn cycle time is the period between loading wood on a coal bed and the consumption of that wood back to a coal bed of the same size. The flaming phase of the fire lasts for roughly the first half of the burn cycle and the second half is the coal bed phase during which there is little or no flame. The burning time expected from this stove, including both phases, will vary depending on a number of things, such as:

- firebox size,
- the amount of wood loaded,
- the species of wood,
- the wood moisture content,
- the size of the space to be heated,
- the climate zone where the house is, and
- the time of the year.

The table below gives an approximate maximum burn cycle times, based on firebox volume.

Table 1 : Approximate Maximum Burn Cycle Time

FIREBOX VOLUME	MAXIMUM BURN CYCLE TIME
<1.5 cubic feet	3 to 5 hours
1.5 c.f. to 2.0 c.f.	5 to 6 hours
2.0 c.f. to 2.5 c.f.	6 to 8 hours
2.5 c.f. to 3.0 c.f.	8 to 9 hours
>3.0 c.f.	9 to 10 hours

A longer burning time is not necessarily an indication of efficient stove operation. It is preferable to build a smaller fire that will provide three or four hours of heating than to fully load the firebox for a much longer burn. Shorter burn cycles make it easier to match the heat output of the stove to the heat demand of the space.

4.6.5 Logs Orientation

In a relatively square fireboxes, the wood can be loaded north-south (ends of the logs visible) or east-west (sides of the logs visible).

North-south loads allow more wood to be loaded at the same time. On the other hand, they break into smaller pieces faster. North-south loading is good for high output, long lasting fires for cold weather. East-west loads allow a limited amount of wood since too much logs could cause them to fall on the glass. East-west loads, placed in a compact way, take a long time before breaking down. They are excellent for low-intensity, long-lasting fires in relatively mild weather.

4.6.6 Carbon Monoxide

When unburned logs remain in the firebox and the flame disappears, go outside and look at the chimney exit. If there is visible smoke, it means that there is still combustible to burn but that the fire lacks air to burn properly. In this situation, the CO rate will increase so it is important to react. Open the door slightly and move the log with a poker. Turn it over and create a passage for the air below, making a trench with the coal bed. Add small pieces of wood to restart the combustion.

5. Maintaining Your Wood Heating System

5.1 Stove Maintenance

This stove will give many years of reliable service if used and maintained properly. Some of the internal components of the firebox, such as firebricks, baffle and air tubes, will wear over time under intense heat. Defective parts should always be replaced with original parts. See [«Appendix 10: Exploded Diagram and Parts List»](#). Firing each load hot to begin a cycle as described above will not cause premature deterioration of the stove. However, letting the stove runs with the air intake fully open for the entire burn cycles can cause damage over time. The hotter the stove becomes throughout burn cycles, the more quickly its components will deteriorate. For this reason, **the stove should never be left unattended while a new load is being fired hot.**

5.1.1 Cleaning Door Glass

Under normal conditions, the door glass should stay relatively clear. If the firewood is dry enough and the operating instructions in this manual are followed, a whitish, dusty deposit will form on the inner surface of the glass after a week or so of use. This is normal and can be easily removed when the stove is cold by wiping with a damp cloth or paper towel and then drying.

Never try to clean the glass when the stove is hot.

In spring and fall when the stove runs at lower temperatures, light brown stains may form, especially in the lower corners of the glass. This indicates that the fire has been smoky and some of the smoke has condensed on the glass. It also indicates incomplete combustion of the wood, which also means more smoke emissions and faster formation of creosote in the chimney. The deposits that form on the glass are the best indication of the fuel quality and and success in properly using the stove.

The goal should be clear glass with no brown stains. If brown stains appears regularly on the glass, something about the fuel or the operating procedure needs to be changed.

These stains can be cleaned with a special wood stove glass cleaner. **Do not use abrasives to clean the stove glass.** When the weather is mild, it is often better to let the fire go out than trying to maintain a continuous fire. Use the technique described in section [«4.6.1 Small Fires to Take the Chill Off the House»](#).

When brown streaks are coming from the edge of the glass, it is time to replace the gasket around the glass. The glass gasket should be self-adhesive. Follow the instructions in section [«5.1.4 Replacing the Glass or the Glass Gasket»](#) for installation. Always replace gaskets with genuine ones. See [«Appendix 10: Exploded Diagram and Parts List»](#).

Do not abuse the glass door by striking or slamming shut.

Do not use the stove if the glass is broken.

5.1.2 Door Adjustment

In order for the stove to burn at its best efficiency, the door must provide a perfect seal with the firebox. Therefore, the gasket should be inspected periodically to check for a good seal.

The gasket seal may be improved with a simple latch mechanism adjustment:

1. Unscrew the nut (A).
2. Remove the door latch (B) and the key path pin (C).
3. Remove or add one washer (D) as needed. Keep the removed washer for future adjustment.
4. Re-install the key path pin (C) in the key-way and slide the latch (B) along it.
5. Secure with the nut (A).

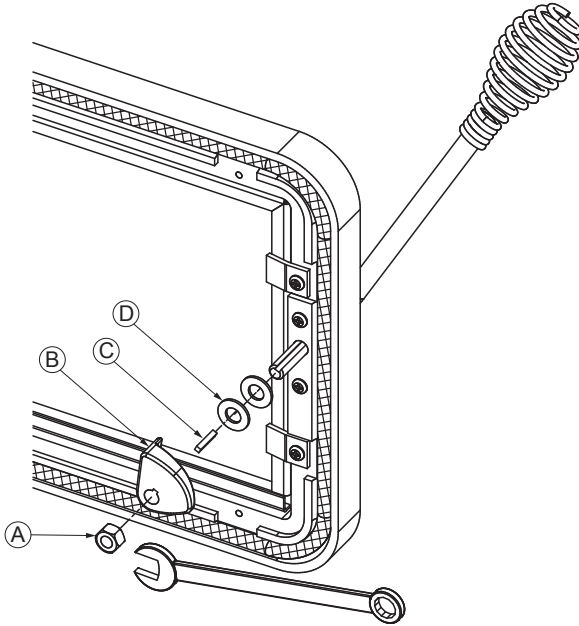

Figure 20: Removing the door latch

5.1.3 Replacing the Door Gasket

It is important to maintain the gasket in good condition. After a year or more of use, the door gasket will compress and become hard, which may allow air to leak. The condition of the door seal can be verified by closing and latching the door on a strip of paper. The test must be performed all around the door. If the paper slips out easily anywhere, it is time to replace the gasket.

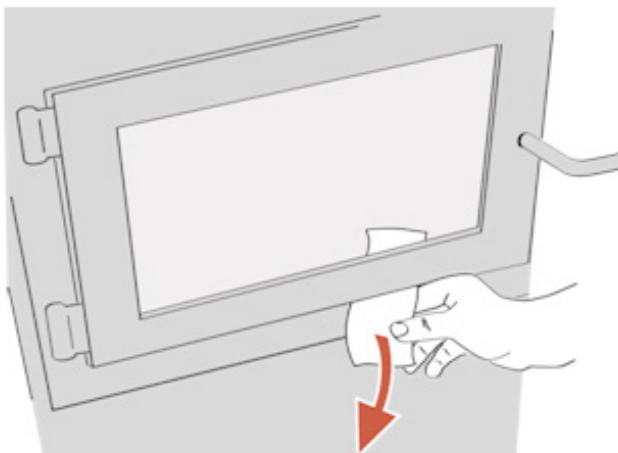

Figure 21: Door gasket seal verification

It is important to replace the gasket with another having the same diameter and density to maintain a good seal.

Remove the door and place it face-down on something soft like a cushion of rags or a piece of carpet. Remove the old gasket from the door by pulling and prying it out with an old screw driver. Then use the screwdriver to scrape the old gasket adhesive from the door gasket groove. Apply a bead of approximately ¼" (6 mm) of high temperature silicone in the door gasket groove. Starting from the middle, hinges side, press the gasket into the groove. The gasket must not be stretched during installation. Leave about ½" long of gasket when cutting and press the end into the groove. Tuck any loose fibers under the gasket and into the silicone. Close the door. Do not use the stove for 24 hours.

5.1.4 Replacing the Glass or the Glass Gasket

To remove or replace the glass **(D)**, remove the eight screws **(A)**, the eight glass retainers **(B)**, and the metal frames **(C)**. Remove the glass. If it is damaged install a new one in place. The replacement glass must have a gasket all around (see procedure below). Reinstall the glass, being careful to centre the glass in the door and not to over-tightening the retaining screw.

The two main causes of broken door glass are uneven placement in the door and over-tightening the retaining screws.

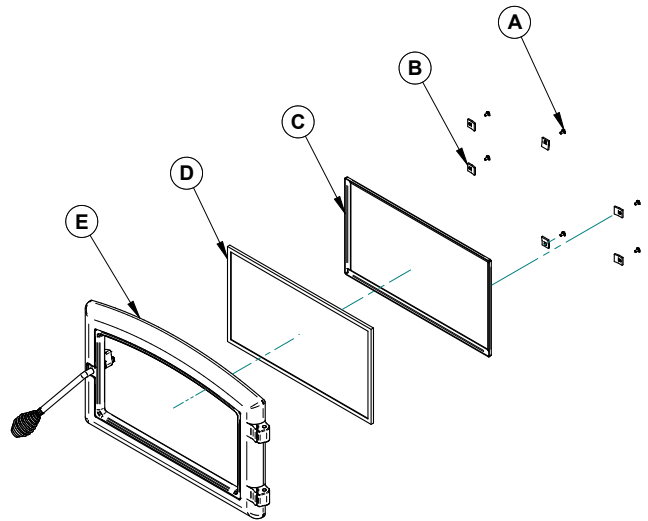
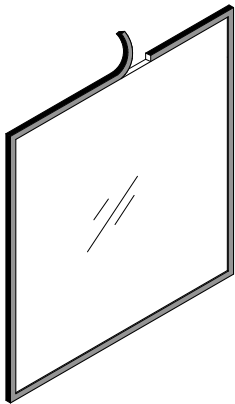

Figure 22: Replacing the glass



It is a good idea to replace the glass gasket when the door gasket is replaced. Follow the previous steps to remove the glass. Remove the old gasket and clean the glass thoroughly. The new gasket is flat, adhesive-backed, woven fibreglass. The gasket must be centred on the edge of the glass. To do this easily, peel back a section of the paper covering the adhesive and place the gasket on a table with the adhesive side up. Stick the end of the gasket to the middle of one edge, then press the edge of the glass down onto the gasket, taking care that it is perfectly centred on the gasket. Peel off more of the backing and rotate the glass. The gasket must not be stretched during installation. Cut the gasket to the required length. Pinch the gasket onto the glass in a U shape, all around the glass.

Do not abuse the glass door by striking or slamming shut.

Do not use the stove if the glass is broken.

5.1.5 Cleaning and Painting the Stove

Painted and plated surfaces can be wiped down with a soft, damp cloth. If the paint is scratched or damaged, it is possible to repaint the stove with a heat-resistant paint. **Do not clean or paint the stove when it is hot.** Before painting, the surface should be sanded lightly with sandpaper and then wiped off to remove dust. Apply two thin layers of paint. For best results, use the original paint, available in aerosol cans.

5.1.6 Firebricks

Before installing the firebrick, ensure that none are broken or damaged in any way, and replace the damaged ones. Check the firebrick for damage at least annually and replace any broken or damaged ones with new ones.

5.2 Chimney Maintenance

5.2.1 Why Cleaning the Chimney Is Necessary

Wood smoke can condense inside the chimney, forming a flammable deposit called creosote. If creosote is allowed to build up in the venting system it can ignite when a hot fire is burned in the stove and a very hot fire can progress to the top of the chimney. Severe chimney fires can damage even the best chimneys. Smouldering, smoky fires can quickly cause a thick layer of creosote to form. When the stove is operated properly, the exhaust from the chimney is mostly clear and creosote builds up more slowly.

5.2.2 How Often Should the Chimney be Cleaned?

It is not possible to predict how much or how quickly creosote will form in the chimney. It is important, therefore, to check the build-up in the chimney monthly until the rate of creosote formation is determined. Even if creosote forms slowly in the system, the chimney should be cleaned and inspected at least once each year.

Contact the local municipal or provincial fire authority for information on how to handle a chimney fire. Have a clearly understood plan to handle a chimney fire.

5.2.3 Sweeping the Chimney

Chimney sweeping can be a difficult and dangerous job. People with no chimney sweeping experience will often prefer to hire a professional chimney sweep to inspect and clean the system for the first time. After seeing the cleaning process, some will choose to do it themselves.

The most common equipment used are fibreglass rods with threaded fittings and stiff plastic brushes. The brush is forced up and down inside the chimney flue to scrub off the creosote.

The chimney should be checked regularly for creosote build-up. Inspection and cleaning of the chimney can be facilitated by removing the baffle. See [«Appendix 9: Air Tubes and Baffle Installation»](#) for more details.

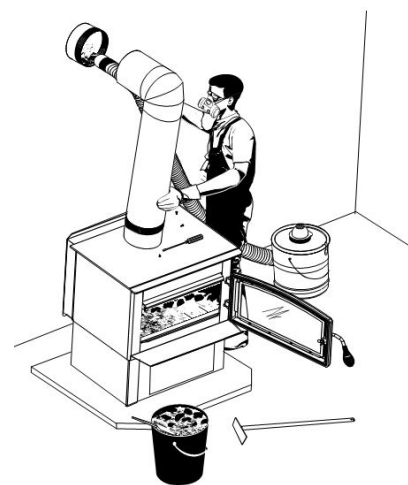

OPERATION OF THIS STOVE WITHOUT THE BAFFLE MAY CAUSE UNSAFE AND HAZARDOUS TEMPERATURE CONDITIONS AND WILL VOID THE WARRANTY.

PART B - INSTALLATION

6. Safety Information and Standards

- The information given on the certification label affixed to the appliance always overrides the information published, in any other media (owner's manual, catalogues, flyers, magazines and web sites).
- Mixing of appliance components from different sources or modifying components may result in hazardous conditions. Where any such changes are planned, Stove Builder International Inc. Should be contacted in advance.
- Any modification of the appliance that has not been approved in writing by the testing authority violates CSA B365 (Canada), and ANSI NFPA 211 (USA).
- **DO NOT CONNECT TO OR USE IN CONJUNCTION WITH ANY AIR DISTRIBUTION DUCTWORK UNLESS SPECIFICALLY APPROVED FOR SUCH INSTALLATION.**
- **DO NOT CONNECT THIS UNIT TO A CHIMNEY FLUE SERVING ANOTHER APPLIANCE.**
- Connect this stove only to a listed factory-built chimney for use with solid fuel or to a lined masonry chimney conforming to national and local building codes.
- If required, a supply of combustion air shall be provided to the room.

ENGLISH

6.1 Mobile Home

- May be installed in a mobile home. The installation requires a fresh air kit, sold separately.
- **DO NOT INSTALL IN SLEEPING ROOM.**
- **THE STOVE MUST BE ATTACHED TO THE STRUCTURE OF THE MOBILE HOME.**
- **THE STRUCTURAL INTEGRITY OF THE MOBILE HOME FLOOR, WALL, CEILING AND ROOF MUST BE MAINTAINED.**

6.2 Regulations Covering Stove Installation

When installed and operated as described in these instructions, this wood stove is suitable for use as a freestanding heater in residential installations.

In Canada, the CSA B365 Installation Code for Solid Fuel Burning Appliances and Equipment and the CSA C22.1 Canadian National Electrical Code are to be followed in the absence of local code requirements. In the USA, the ANSI NFPA 211 Standard for Chimneys, Fireplaces, Vents and Solid Fuel-Burning Appliances and the ANSI NFPA 70 National Electrical Code are to be followed in the absence of local code requirements.

This stove must be connected to a chimney complying with the requirements for Type HT chimneys in the Standard for Factory-Built Chimneys for Residential Type and Building Heating Appliances, UL 103 and ULC S629 or to a code-approved masonry chimney with a flue liner.

7. Clearances to Combustible Material

The clearances shown in this section have been determined by test according to procedures set out in safety standards ULC S627 (Canada), UL 1482 (U.S.A.) and UL 737 (U.S.A.). When the stove is installed so that its surfaces are at or beyond the minimum clearances specified, combustible surfaces will not overheat under normal and even abnormal operating conditions.

No part of the stove or flue pipe may be located closer to combustibles than the minimum clearance figures given.

7.1 Location of the Certification Label

Since the information given on the certification label affixed to the appliance always overrides the information published, in any other media (owner's manual, catalogues, flyers, magazines and web sites) it is important to refer to it in order to have a safe and compliant installation. In addition, important information about the stove can be found (model, serial number, etc.). The certification label is located on the back of the stove.

It is recommended to note the stove serial number on page 5 of this manual since it will be needed to precisely identify the version of the appliance in the event replacement parts or technical assistance is required. It is also recommended to [register the warranty online](#).

7.2 Clearances to Combustible Materials

The clearances to combustible walls may be slightly different in Canada and the U.S.A. and may also differ depending on whether single or double wall flue pipe is used. Make sure to choose the correct clearance for the stove location and type of flue pipe.

The clearances of the appliance and the flue pipes must be met individually, meaning the appliance can not be installed closer to the combustible materials than the single or double wall pipe allows. For a safe way to reduce clearances refer to section [«7.4 Reducing Wall and Ceiling Clearances Safely»](#)

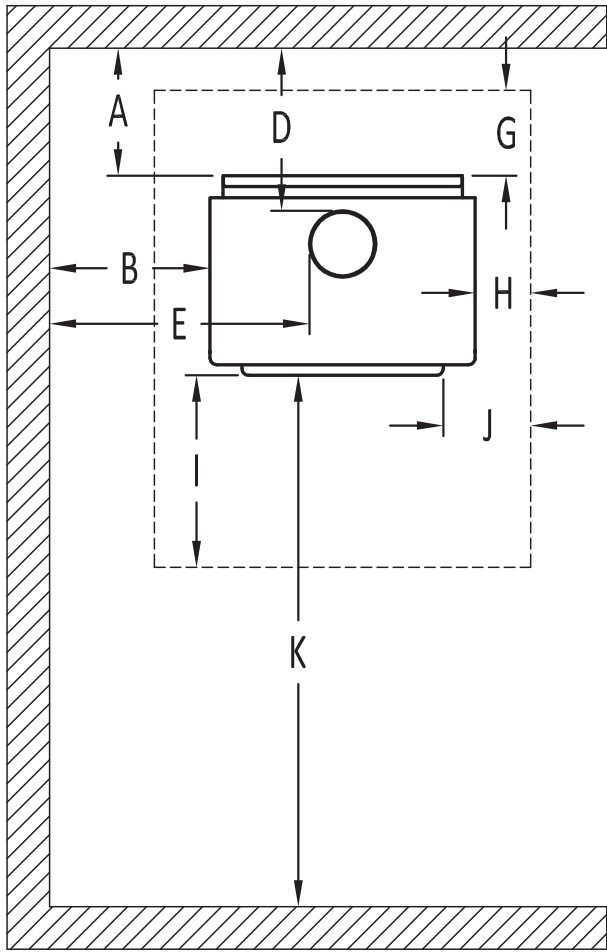

Figure 23: Clearances -Side

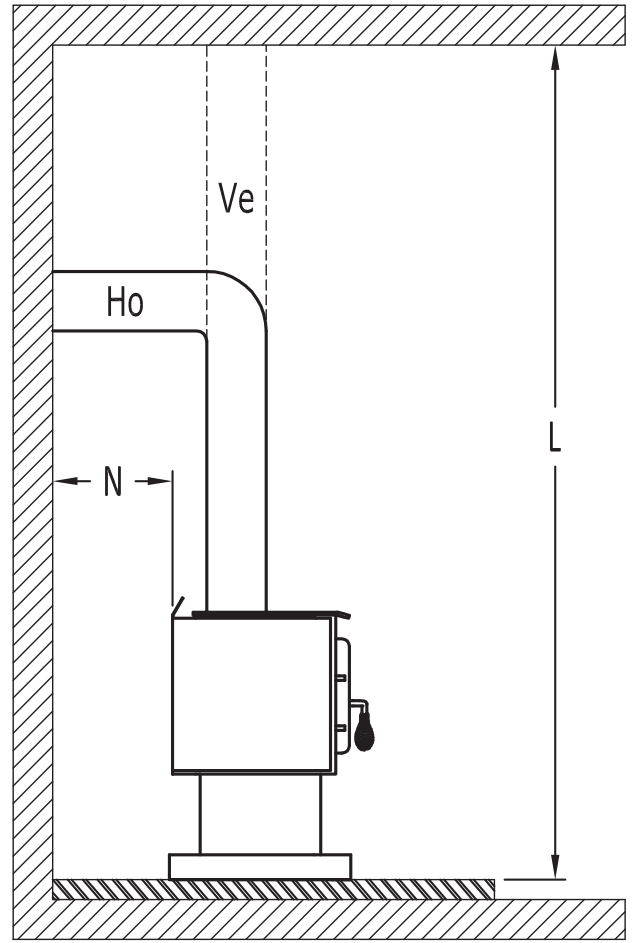

Figure 24: Clearances - Top

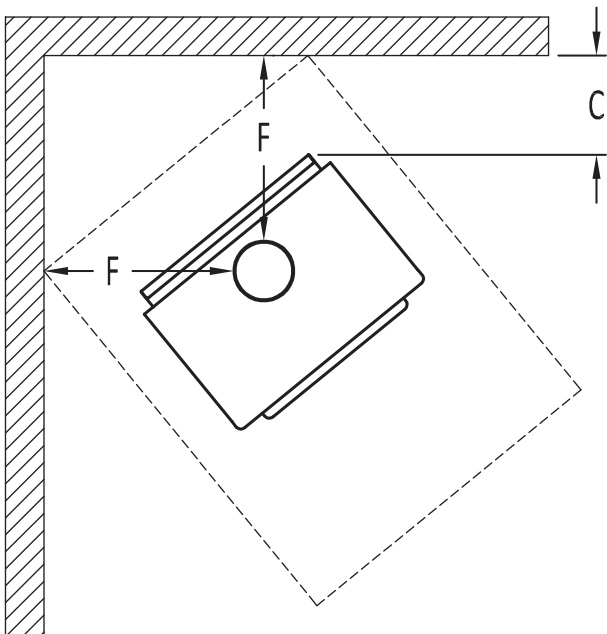

Figure 25: Clearances - Corner

	APPLIANCE CLEARANCES (INSTALLATION WITH SINGLE WALL PIPE CONNECTOR)	
	Canada	USA
A	14 ½" (368 mm)	11" (279 mm)
B	17" (432 mm)	16" (406 mm)
C	10" (254 mm)	10" (254 mm)
K	48" (122 cm)	48" (122 cm)
L	84" (213 cm)	84" (213 cm)

	APPLIANCE CLEARANCES (INSTALLATION WITH DOUBLE WALL PIPE CONNECTOR)	
	Canada	USA
A	6" (152 mm)	6" (152 mm)
B	17" (432 mm)	16" (406 mm)
C	7" (178 mm)	7" (178 mm)
K	48" (122 cm)	48" (122 cm)
L	84" (213 cm)	84" (213 cm)

If the above clearances are met, then the distances measured from the flue outlet will be:

	DISTANCES ¹ FROM PIPE CONNECTOR WITH SINGLE WALL PIPE CONNECTOR	
	Canada	USA
D	18" (457 mm)	14 ½" (368 mm)
E	26 ½" (673 mm)	25 ½" (648 mm)
F	19 ¾" (502 mm)	19 ¾" (502 mm)

	DISTANCES ¹ FROM PIPE CONNECTOR WITH DOUBLE WALL PIPE CONNECTOR	
	Canada	USA
D	9 ¼" (235 mm)	9 ¼" (235 mm)
E	26 ¼" (667 mm)	25 ¼" (641 mm)
F	16 ½" (419 mm)	16 ½" (419 mm)

7.2.1 Clearances with heat shield AC02710

Note that to reduce the clearances of an appliance using a single wall pipe connector, the use of a heat shield certified with the single wall pipe connector to be used as close as 6" from combustible materials must be used. Only in this case, the same clearances as a certified double wall pipe connector can be used.

	APPLIANCE CLEARANCES (INSTALLATION WITH DOUBLE WALL PIPE CONNECTOR)	
	Canada	USA
A	3" (76 mm)	3" (76 mm)
B	4" (102 mm)	4" (102 mm)
C	3" (76 mm)	3" (76 mm)
K	48" (122 cm)	48" (122 cm)
L	84" (213 cm)	84" (213 cm)

	DISTANCES ¹ FROM DOUBLE WALL PIPE CONNECTOR	
	Canada	USA
D	6 ¼" (159 mm)	6 ¼" (159 mm)
E	13 ¼" (337 mm)	13 ¼" (337 mm)
F	12 ½" (318 mm)	12 ½" (318 mm)

¹ The pipe distances listed in this table refer to the distances obtained when the stove is installed in accordance with the appliance clearances above mentioned.

7.2.2 Clearances With Lowered Ceiling

	APPLIANCE CLEARANCES (INSTALLATION WITH SINGLE WALL PIPE CONNECTOR)	
	Canada	USA
A	14 ½" (368 mm)	11" (279 mm)
B	19" (483 mm)	18" (457 mm)
C	10" (254 mm)	10" (254 mm)
K	48" (122 cm)	48" (122 cm)
L	77" (196 cm)	77" (196 cm)

	APPLIANCE CLEARANCES (INSTALLATION WITH DOUBLE WALL PIPE CONNECTOR)	
	Canada	USA
A	9" (229 mm)	9" (229 mm)
B	19" (483 mm)	19" (483 mm)
C	7" (178 mm)	7" (178 mm)
K	48" (122 cm)	48" (122 cm)
L	77" (196 cm)	77" (196 cm)

If the above clearances are met, then the distances measured from the flue outlet will be:

	DISTANCES FROM PIPE CONNECTOR WITH SINGLE WALL PIPE CONNECTOR	
	Canada	USA
D	18" (457 mm)	14 ½" (368 mm)
E	28 ½" (724 mm)	27 ½" (699 mm)
F	19 ¾" (502 mm)	19 ¾" (502 mm)

	DISTANCES ² FROM PIPE CONNECTOR WITH DOUBLE WALL PIPE CONNECTOR	
	Canada	USA
D	12 ¼" (311 mm)	12 ¼" (311 mm)
E	28 ¼" (718 mm)	28 ¼" (718 mm)
F	16 ½" (419 mm)	16 ½" (419 mm)

7.2.3 Clearances with heat shield AC02710 and lowered ceiling

To reduce the clearances of an appliance using a single wall pipe connector, the use of a heat shield certified with the single wall pipe connector to be used as close as 6" from combustible materials must be used. Only in this case, the same clearances as a certified double wall pipe connector can be used.

	APPLIANCE CLEARANCES (INSTALLATION WITH DOUBLE WALL PIPE CONNECTOR)	
	Canada	USA
A	5" (127 mm)	5" (127 mm)
B	6" (152 mm)	6" (152 mm)
C	5" (127 mm)	5" (127 mm)
K	48" (122 cm)	48" (122 cm)
L	80" (203 cm)	80" (203 cm)

	DISTANCES ² FROM DOUBLE WALL PIPE CONNECTOR	
	Canada	USA
D	8 ¼" (210 mm)	8 ¼" (210 mm)
E	15 ¼" (387 mm)	15 ¼" (387 mm)
F	14 ½" (368 mm)	14 ½" (368 mm)

² The pipe distances listed in this table refer to the distances obtained when the stove is installed in accordance with the appliance clearances above mentioned.

7.2.4 Clearances Inside an Alcove

	APPLIANCE CLEARANCES (INSTALLATION WITH DOUBLE WALL PIPE CONNECTOR)	
	Canada	USA
A	9" (229 mm)	9" (229 mm)
B	19" (483 mm)	19" (483 mm)
K	48" (122 cm)	48" (122 cm)
L	77" (196 cm)	77" (196 cm)

	DISTANCES ³ FROM PIPE CONNECTOR WITH DOUBLE WALL PIPE CONNECTOR	
	Canada	USA
D	12 ¼" (311 mm)	12 ¼" (311 mm)
E	28 ¼" (718 mm)	28 ¼" (718 mm)

7.2.6 Clearances For Mobile Homes

It is strictly forbidden to install a unit with single wall pipe in a mobile home.

	MOBILE HOME CLEARANCES (INSTALLATION WITH DOUBLE WALL PIPE CONNECTOR)	
	Canada	USA
A	11" (279 mm)	11" (279 mm)
B	18" (457 mm)	18" (457 mm)
C	11" (279 mm)	11" (279 mm)
K	48" (122 cm)	48" (122 cm)
L	84" (213 cm)	84" (213 cm)

	DISTANCES ³ FROM PIPE CONNECTOR WITH DOUBLE WALL PIPE CONNECTOR	
	Canada	USA
D	14 ¼" (362 mm)	14 ¼" (362 mm)
E	27 ¼" (692 mm)	27 ¼" (692 mm)
F	20 ½" (521 mm)	20 ½" (521 mm)

7.2.7 Clearances with heat shield AC02710 in a mobile home

	MOBILE HOME CLEARANCES (INSTALLATION WITH DOUBLE WALL PIPE CONNECTOR)	
	Canada	USA
A	3" (76 mm)	3" (76 mm)
B	6" (152 mm)	6" (152 mm)
C	3" (76 mm)	3" (76 mm)
K	48" (122 cm)	48" (122 cm)
L	84" (213 cm)	84" (213 cm)

	DISTANCES ³ FROM PIPE CONNECTOR WITH DOUBLE WALL PIPE CONNECTOR	
	Canada	USA
D	6 ¼" (159 mm)	6 ¼" (159 mm)
E	15 ¼" (387 mm)	15 ¼" (387 mm)
F	12 ½" (318 mm)	12 ½" (318 mm)

³ The pipe distances listed in this table refer to the distances obtained when the stove is installed in accordance with the appliance clearances above mentioned.

7.3 Floor Protector

This stove is designed to prevent the floor from overheating. However, it must be placed on a non-flammable surface to protect the floor from hot embers that may fall during loading. The floor protection must be a continuous, non combustible material, such as steel with a minimum thickness of 0.015" (0.38 mm) or ceramic tiles sealed together with grout. Cement board, brick, or any other approved or listed material suited for floor protection. Any type of tile will require a continuous non combustible sheet beneath to prevent the possibility of embers falling through to the combustible floor if cracks or separation should occur in the finished surface. Check local codes for approved alternatives. No protection is required if the unit is installed on a non-combustible floor (ex: concrete). See table and figure below.

Table 2 : Floor Protection

	FLOOR PROTECTION	
	Canada	USA
G	8" (203 mm) ¹ Note 1	N/A
H	8" (203 mm)	N/A
I	18" (457 mm) From door opening	16" (203 mm) From door opening
J	N/A	8" (203 mm)
N	N/A	Note 2

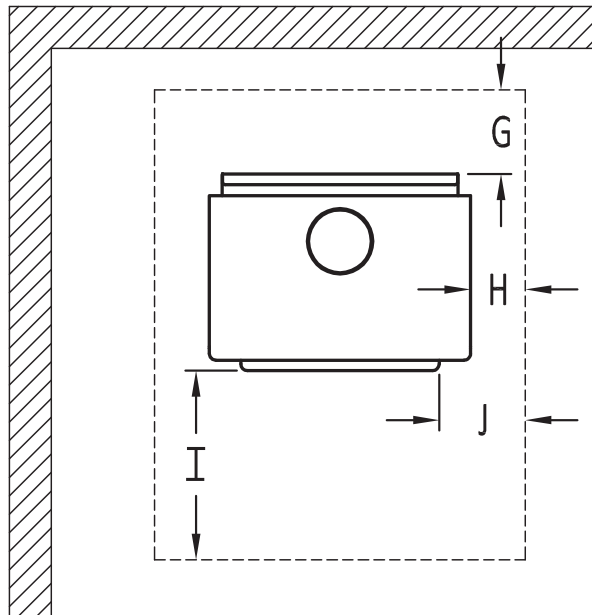

Figure 26: Floor Protection

7.3.1 Floor Protection in a Mobile Home

When the stove is installed in a mobile home and assembled on the legs version, the stove must be placed on a podium having a **maximum** dimension of 30" (762 mm) x 24" (610 mm) and a minimum height of 2" (51 mm). This podium can be constructed of combustible materials as long as it is covered of non-combustible materials.

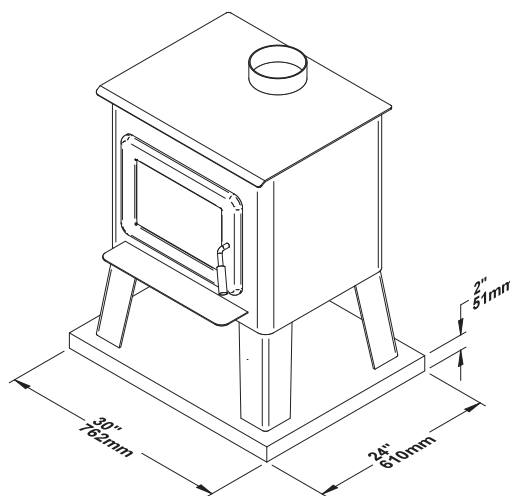

Figure 27: Floor protection in a mobile home

Note 1: The floor protection at the back of the stove is limited to the stove's required clearance if such clearance is smaller than 8 inches (203 mm).
 Note 2: Only required under the horizontal section of the connector. Must exceed each side of the connector by at least 2 inches (51 mm). See [«Figure 24: Clearances - Side»](#)

7.4 Reducing Wall and Ceiling Clearances Safely

It is often desired to use as little space as possible when installing a woodstove. To do this, it is possible to reduce the clearances safely and install the stove closer to the walls by permanently installing a heat shield between the stove and the flammable material. The rules for heat shield are sometimes complicated. Read and apply the instructions carefully. Some regions may have different regulations. Consult the local building code or contact the fire department for restrictions, inspection and installation requirements in the area.

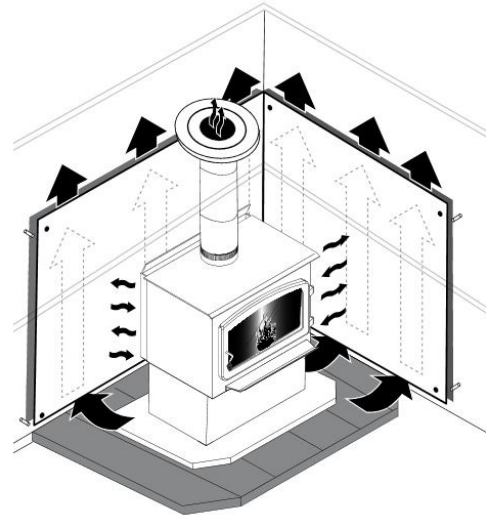

Figure 28: Heat shield

7.4.1 Shield Construction Rules

- Adhesives used in shield construction must not ignite or lose adhesive qualities at temperatures likely to be encountered.
- Mounting hardware which extends from the shield surface into combustibles may be used only at the edges of the shield.
- Mounting hardware must allow full vertical ventilation.

See figures on next page for shield construction to match each letter to a clearance.

- A) Minimum clearance between the appliance top and an unshielded combustible ceiling: 1180 mm (46 ½").
- B) Shield extension above appliance: 500 mm (20").
- C) Minimum space behind shield: 25 mm (1"). In Canada 21 mm (7/8").
- D) Clearance along the bottom of shield: minimum 25 mm (1") and maximum 75 mm (3").
- E) Minimum clearance along the top of shield at ceiling: 75 mm (3").
- F) Mounting hardware must not be located closer than 200 mm (8") from the vertical centre line of the appliance.
- G) Edge clearance for ceiling shields to side and back walls: 75 mm (3").
- H) Shield extension beyond each side of appliance: 450 mm (18").

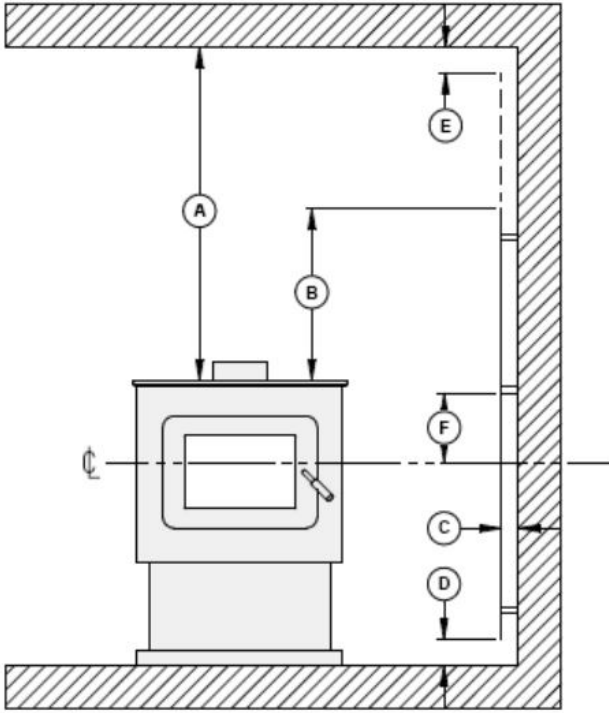

Figure 29: Heat shield clearances

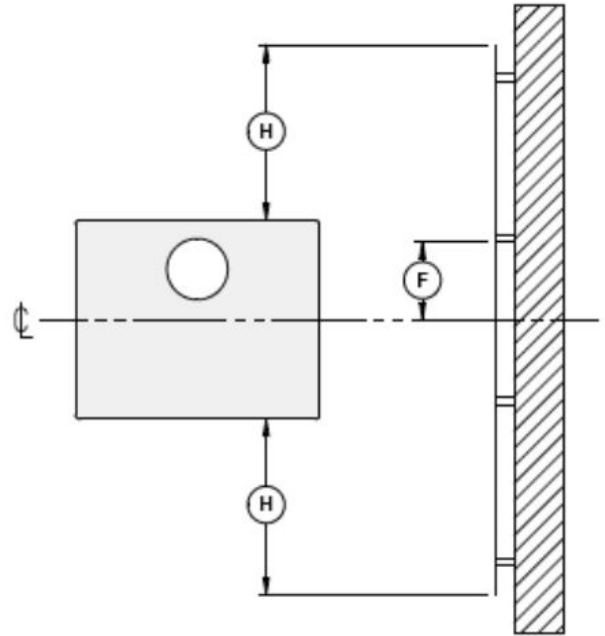

Figure 30: Heat shield clearances

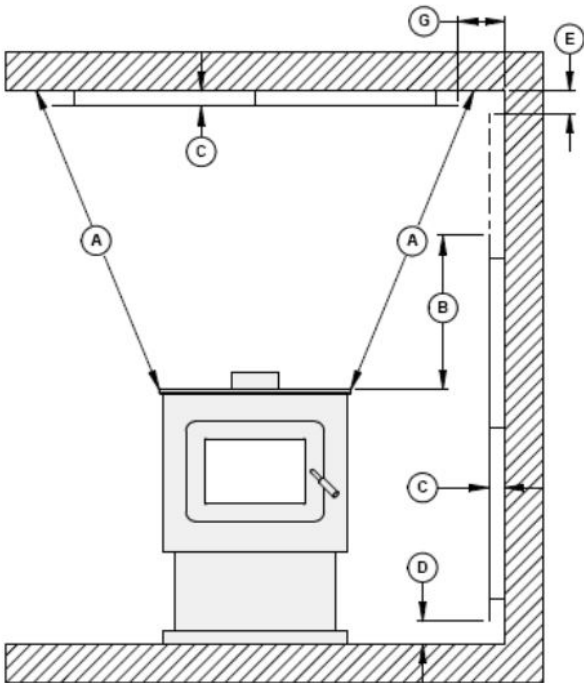
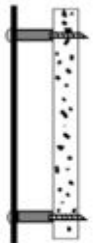







Figure 31: Heat shield clearances

TYPE OF SHIELD	CLEARANCES MAY BE REDUCED BY THESE PERCENTAGES				
	SIDES AND REAR		TOP (CEILING)		
	CAN /USA (%)	USA MIN.	CAN /USA (%)	USA MIN.	
Sheet metal, a minimum of 24 gauge (0.61 mm) in thickness , spaced out at least 25 mm (1 in)* by non-combustible spacers	67	12"	50	18"	
Ceramic tiles, or equivalent non-combustible material, on non-combustible board spaced out at least 25 mm (1 in)* by non-combustible spacers	50	18"	33	24"	
Ceramic tiles, or equivalent non-combustible material, on non-combustible board, with a minimum of 24 gauge (0.61 mm) sheet metal backing spaced out at least 25 mm (1 in)* by non-combustible spacers	67	12"	50	24"	
Brick, spaced out at least 25 mm (1 in)* by non-combustible spacers	50	18"	N/A	N/A	
Brick, with a minimum of 24 gauge (0.61 mm) sheet metal backing, spaced out at least 25 mm (1 in)* by non-combustible spacers	67	12"	N/A	N/A	

* In Canada this space can be 21 mm (7/8").

8. The Venting System

8.1 General

The venting system, made of the chimney and the connecting pipe between the stove and the chimney, acts as the engine that drives the wood heating system. Even the best stove will not function safely and efficiently if it is not connected to a suitable chimney.

The heat in the flue gases that pass from the stove and chimney connector into the chimney is not waste heat. This heat is what the chimney uses to make the draft that draws in combustion air, keeps smoke inside the stove and safely vents exhaust to outside. The heat in the flue gas can be seen as the fuel the chimney uses to create draft.

8.2 Suitable Chimneys

This stove will provide optimum efficiency and performance when connected to a 6" diameter chimney flue system. The connection to a chimney having a diameter of at least 5" (Canada only) or no more than 7" is permitted, if it allows the proper venting of combustion gases and that such application is verified and authorized by a qualified installer. Otherwise, the diameter of the flue should be 6".

To be suitable, a factory-built metal chimney must comply with UL 103 HT (U.S.A.) or ULC S629 (Canada).

8.2.1 Factory-Built Metal Chimneys

These are sometimes referred to as 'high temp' chimneys because they have the specific characteristics to withstand the temperatures that can be created by wood burning stoves. Factory-built chimneys are tested as a system with all the necessary components for installation. The instructions provided with the chimney by its manufacturer are the only reliable source of installation guidelines. To be safe and effective, the chimney must be installed exactly in accordance with the manufacturer's instructions. Only components intended for the brand and model of chimney should be used. Never fabricated or substitute parts from other chimney brands. The chimney must be a type suitable for solid fuel.

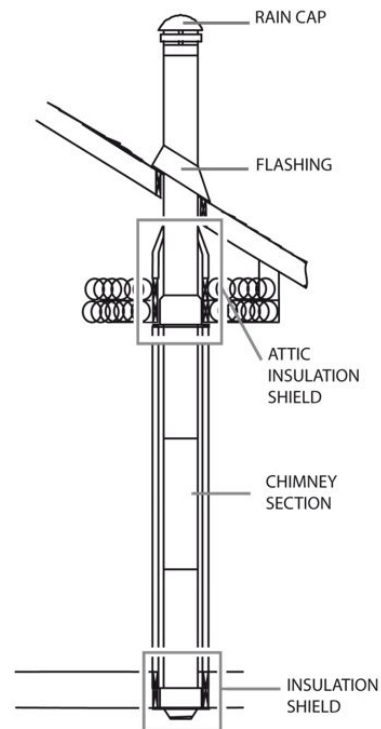

8.2.2 Factory-Built Metal Chimneys in Mobile Homes

For use in a mobile home, this stove is to be connected to a 6" double wall factory built chimney pipe conforming to UCL-S629, standards for 650°C Factory-built chimney. The total length of the flue system should be at least 12 feet including elbows, from the top of the stove.

To maintain an effective vapour barrier, insulation and waterproof at the chimney and outside flue pipe, a roof flashing must be installed and sealed with silicone adhesive.

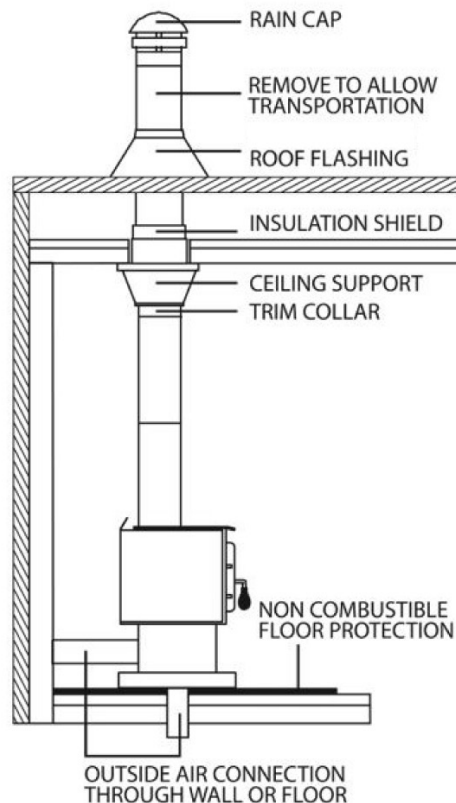

8.2.3 Masonry Chimneys

The stove may also be connected to a masonry chimney, provided the chimney complies with the construction rules found in the building code enforced locally. The chimney must have either a clay liner or a suitably listed stainless steel liner. If the masonry chimney has a square or rectangular liner that is larger in cross sectional area than a round 6" flue, it should be relined with a suitably listed 6" stainless steel liner. Do not downsize the flue to less than 6" unless the venting system is straight and exceeds 25 feet in height. When passing through a combustible wall, the use of an insulated listed thimble is required.

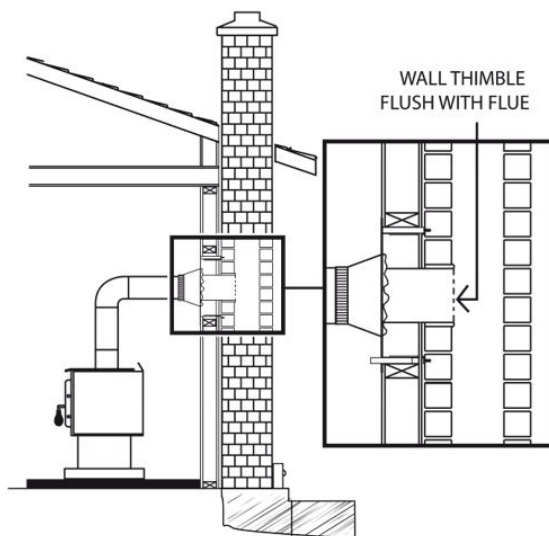

8.3 Minimum Chimney Height

The top of the chimney should be tall enough to be above the air turbulence caused when wind blows against the house and its roof. The chimney must extend at least 1 m (3 ft.) above the highest point of contact with the roof, and at least 60 cm (2 ft.) higher than any roof line or obstacle within a horizontal distance of 3 m (10 ft.).

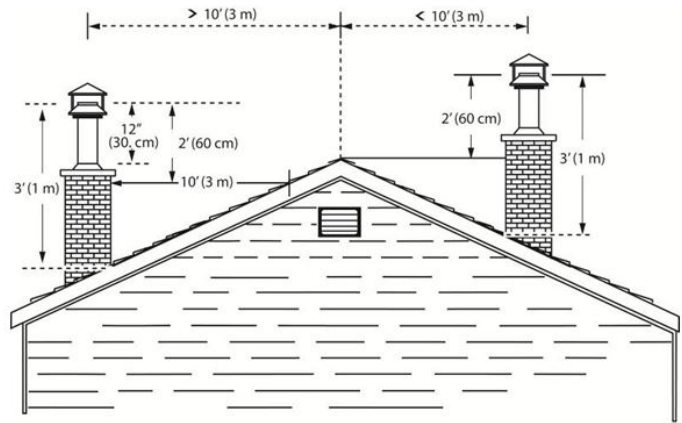

8.4 The Relationship Between the Chimney and the House

Because the venting system is the engine that drives the wood heating system, it must have the right characteristics. The signs of bad system design are cold backdrafting when there is no fire in the stove, slow kindling of new fires, and smoke roll-out when the door is opened for loading. There are two guidelines to follow. First, the chimney should be installed up through the heated space of the house, not out and up an outside wall. Second, the chimney should penetrate the top of the building at or near the highest heated space.

8.4.1 Why Inside Chimneys Are Preferred

Venting systems that rise straight up from the stove flue collar provide the best performance. Chimneys that rise inside the warm space of the house tend to provide a small amount of draft even when there is no fire burning. This means that when a fire is lit, the smoke goes up the chimney and strong draft builds quickly as the chimney flue warms up. Although they are common in North America, chimneys that exit a house wall and run up outside can cause problems.

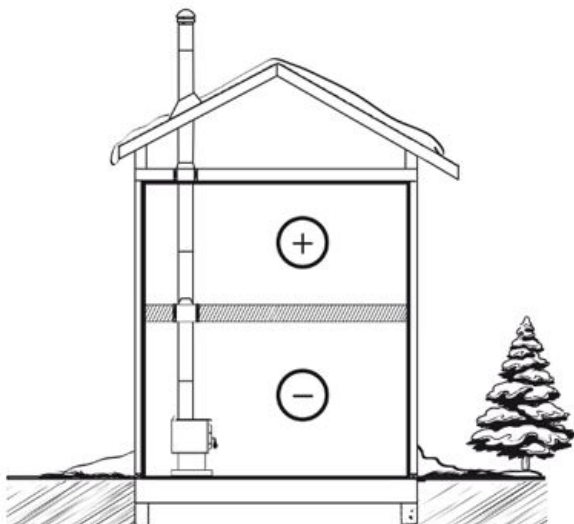

Figure 32: Good System Design

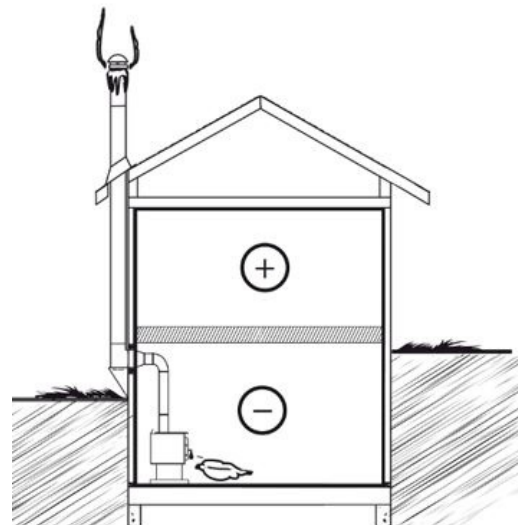

Figure 33: Inferior System Design

8.4.2 Why the Chimney Should Penetrate the Highest Heated Space

When it is cold outside, the warm air in the house is buoyant so it tends to rise. This creates a slight pressure difference in the house. Called ‘stack effect’, it produces a slightly negative pressure in the lower part of the house (compared to the outside) and a slightly positive pressure zone in the high part of the house. If there is no fire burning in a heater connected to a chimney that is shorter than the warm space inside the house, the slight negative pressure in the lower part of the house will compete against the desired upward flow in the chimney. This occurs for the two following reasons:

First, the chimney runs up the outside of the house, so the air in it is colder and denser than the warm air in the house. And second, the chimney is shorter than the heated space of the house, meaning the negative pressure in the lower part of the house will draw cold air down the chimney, through the stove and into the room. Even the finest stove will not work well when connected to this chimney.



Figure 34: Chimney location in the house

8.5 Supply of Combustion Air

In Canada, wood stoves are not required to have a combustion air supply from outside, except for mobile homes. Research has shown that outside air supply do not compensate for the depressurization of the house and may not be sufficient to provide a supply of combustion air in windy weather. However, to reduce the risks against smoke spillage due to house depressurization, a carbon monoxide (CO) detector is required in the room where the stove is installed. The CO detector will provide warning if for any reason the wood stove fails to function correctly.

8.5.1 Combustion Air Supply in Mobile Homes

This stove is ‘mobile home approved’. It must therefore have a supply of combustion air from outdoors. The air intake must not draw air from the attic, from the basement, from a garage or any enclosed space. Air must be drawn from a ventilated crawl space under the floor or directly from outside. Install a flexible or rigid, insulated pipe (HVAC type, must comply to ULC S110 and/or UL 181, Class 0 or Class 1) to the fresh air intake.

Where a mobile home has been converted to a standard house by mounting it on a permanent basement foundation, the supply of outdoor air is not required.

8.5.2 Air Supply in Conventional Houses

The safest and most reliable supply of combustion air for a wood stove is from the room in which it is installed. Room air is already preheated so it will not chill the fire, and its availability is not affected by wind pressures on the house.

Contrary to commonly expressed concerns, almost all tightly-sealed new houses have enough natural leakage to provide the small amount of air needed by the stove. The only case in which the wood stove may not have adequate access to combustion air is if the operation of a powerful exhaust device (such as a kitchen range exhaust) causes the pressure in the house to become negative relative to outdoors.

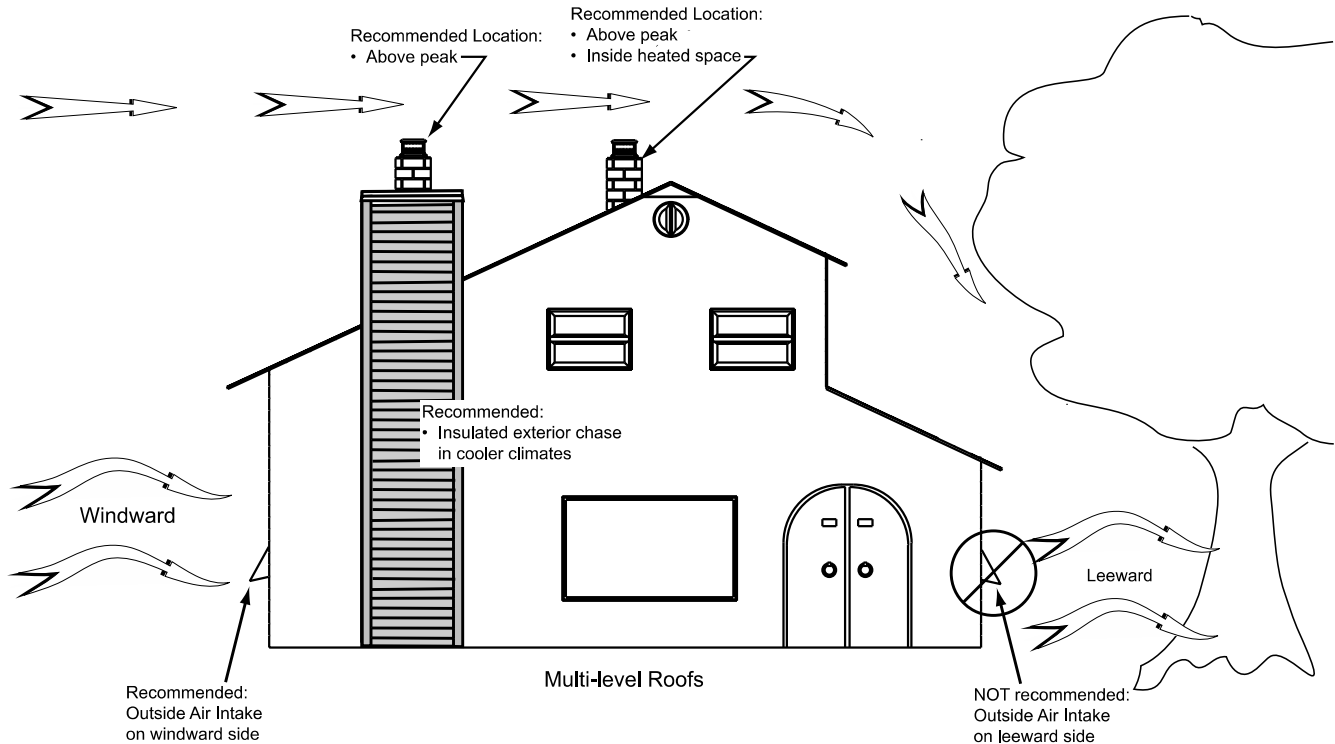

Figure 35: Air supply in conventional houses

If an air intake is installed through the wall of the house, its pressure can vary during windy weather. If there are changes in wood stove performance in windy weather, and in particular if smoke puffs from the stove, the air duct should be disconnected from the stove to determine if it is the cause of the problem. In some windy conditions, negative pressure at the duct weatherhood outside the house wall may draw hot exhaust gases from the stove backwards through the duct to outdoors. Check the outdoor air duct for soot deposits when the full system is cleaned and inspected at least once each year.

8.6 Installing the Chimney Connector

The chimney connector is the single or double wall pipe installed between the stove flue collar and the chimney breech. Single wall pipe components are available from most hardware and building supply stores. These components are not usually tested to a particular standard and certified as compliant. Therefore, a list of rules found in solid fuel installation codes apply to the installation of single wall pipe.

Double wall chimney connectors are tested and certified. The rules for double wall pipe are found in the manufacturer's installation instructions. These rules will be very different than those for single wall.

8.6.1 Installation of Single Wall Chimney Connector

The chimney connector assembly has been called ‘the weak link’ in the safety of wood heating systems because failure to install the connector properly (which has been common in the past) can result in house fires.

The best flue pipe assembly is one that rises straight up from the stove to the base of the chimney with no elbows. Straight assemblies are less likely to cause problems like smoke roll-out when the door is opened for loading. They are also more stable and easier to maintain than assemblies with elbows. Horizontal runs of flue pipe should be avoided where possible because they reduce chimney draft.

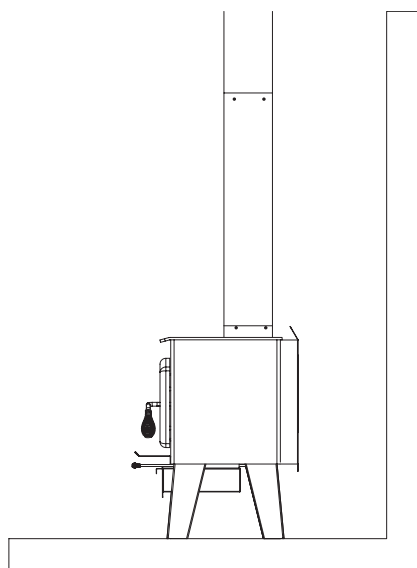

Figure 36: Best

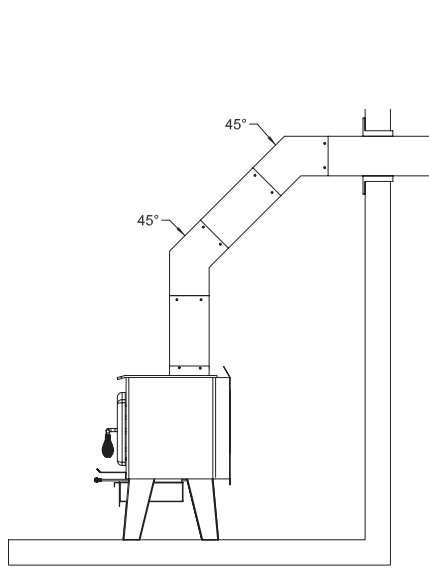

Figure 37: Acceptable

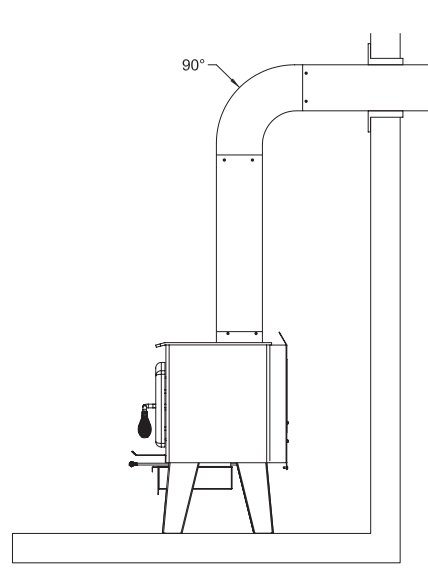

Figure 38: Avoid

ENGLISH

The rules below are based on those found in the CSA B365 installation code. Please carefully follow these installation instruction rules, or those enforced by the local code.

- Maximum overall length of horizontal pipe: 3 m (10 ft.) including elbows.
- Minimum clearance from combustible material: 450 mm (18 in.). The minimum clearance may be reduced by 50 percent to 225 mm (9 in.) if suitable shielding is installed either on the pipe or on the combustible surface.
- The assembly should be as short and direct as possible between the stove and chimney. The use of two 45 degree elbows is often preferable to a single 90 degree elbow because less turbulence is created in the exhaust flow and they result in less horizontal run.
- Maximum number of 90-degree elbows: 2.
- Maximum unsupported horizontal length: 1 m (3 feet).
- Galvanized flue pipes must not be used because the coatings vaporize at high temperatures and release dangerous gases. Use black painted flue pipes.
- Flue pipes must be at least 24 gauge in thickness.
- Flue pipe joints should overlap 30 mm (1 1/4 in.)

- Each joint in the assembly must be fastened with at least three screws.
- The assembly must have allowance for expansion: elbows in assemblies allow for expansion; straight assemblies should include an inspection wrap with one end unfastened, or a telescopic section.
- Minimum upward slope towards the chimney: 20 mm/m (1/4 in/ft.).
- One end of the assembly must be securely fastened to the flue collar with 3 sheet metal screws and the other end securely fastened to the chimney.
- There must be provision for cleaning of the pipes, either through a clean out or by removal of the pipe assembly. Removal of the assembly should not require that the stove be moved.
- The male ends of the sections must be oriented towards the appliance so that falling dust and condensation stay inside the pipe.
- A flue pipe must never pass through a combustible floor or ceiling or through an attic, roof space, closet or concealed space.
- Where passage through a wall or partition of combustible construction is desired, the installation shall conform to CAN/CSA-B365, Installation Code for Solid-Fuel-Burning Appliances and Equipment.
- A straight up connector assembly needs either a telescopic length or an inspection wrap (pipe coupler) to allow it to be assembled and disassembled without moving the stove.
- A straight flue pipe assembly offers the least restriction to gas flow and results in stronger draft. Straight assemblies also need less maintenance because there are no corners to collect creosote.
- The chimney connector must be in good condition.

APPENDIX 1 : LEGS INSTALLATION

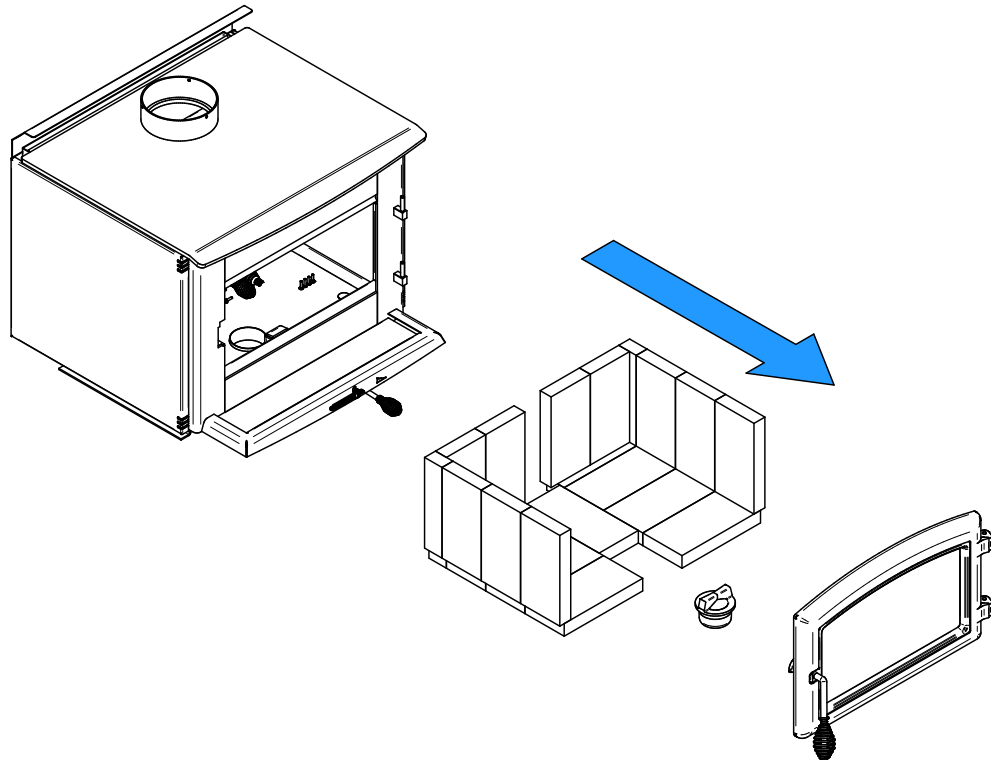

1. Remove the door, the firebricks, and the ash plug from the stove.

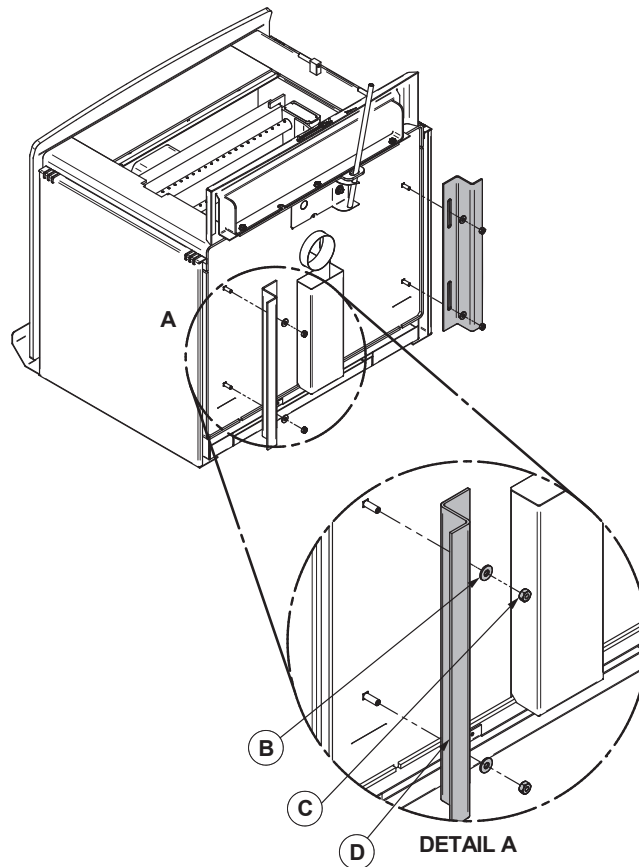

2. Put the stove on its back. Remove and dispose of the two freight supports **(D)**. Keep the nuts **(C)** and washers **(B)** for step 4.

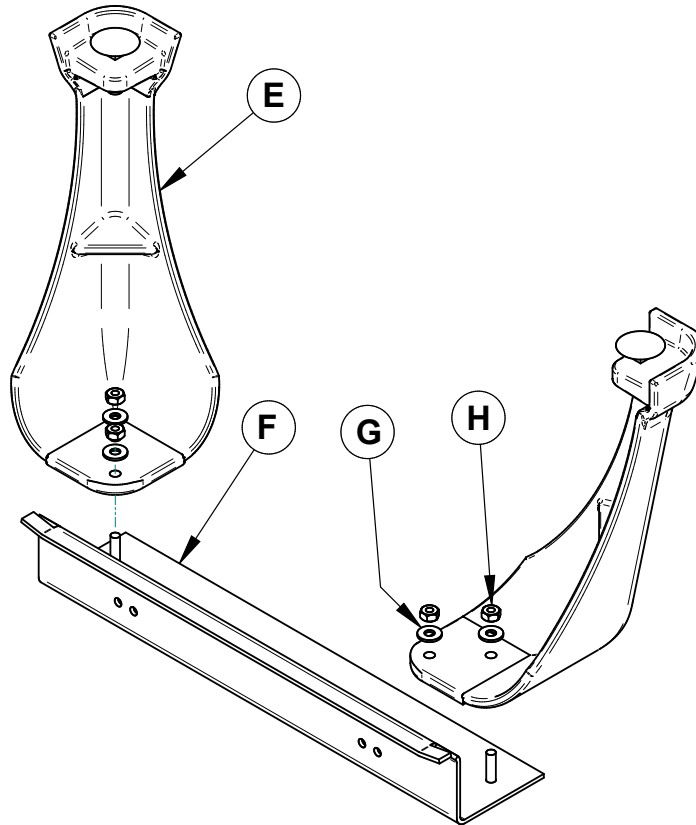

3. Install the legs **(E)** on the legs supports **(F)**. Secure with the washers **(G)** and nuts **(H)** supplied with the leg assembly.

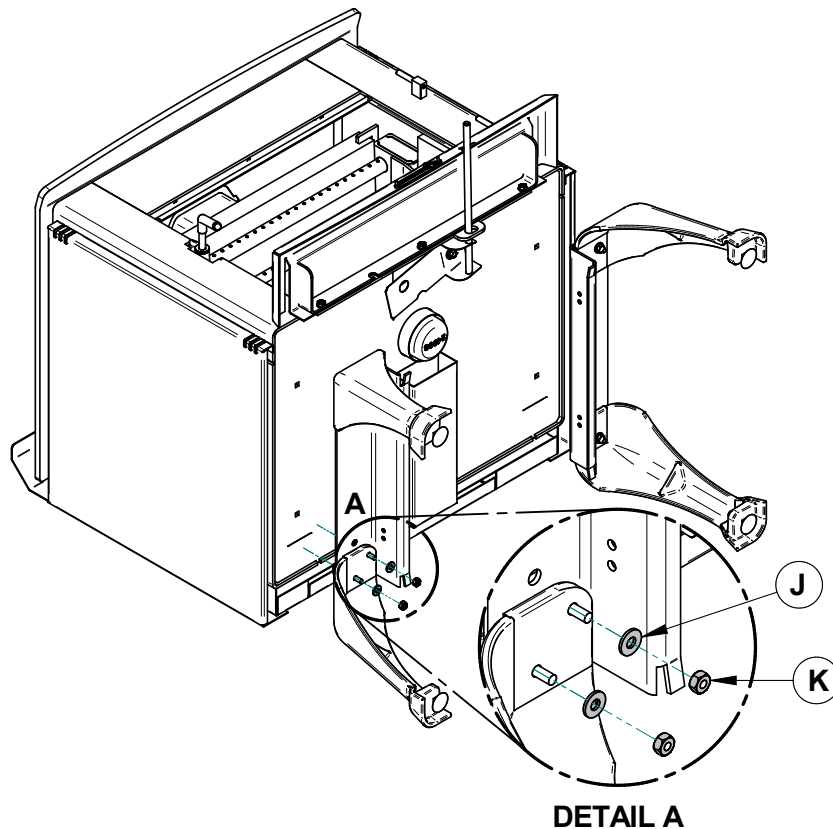

4. With the nuts **(K)** and washers **(J)** removed in step 1; secure both leg assemblies to the stove.

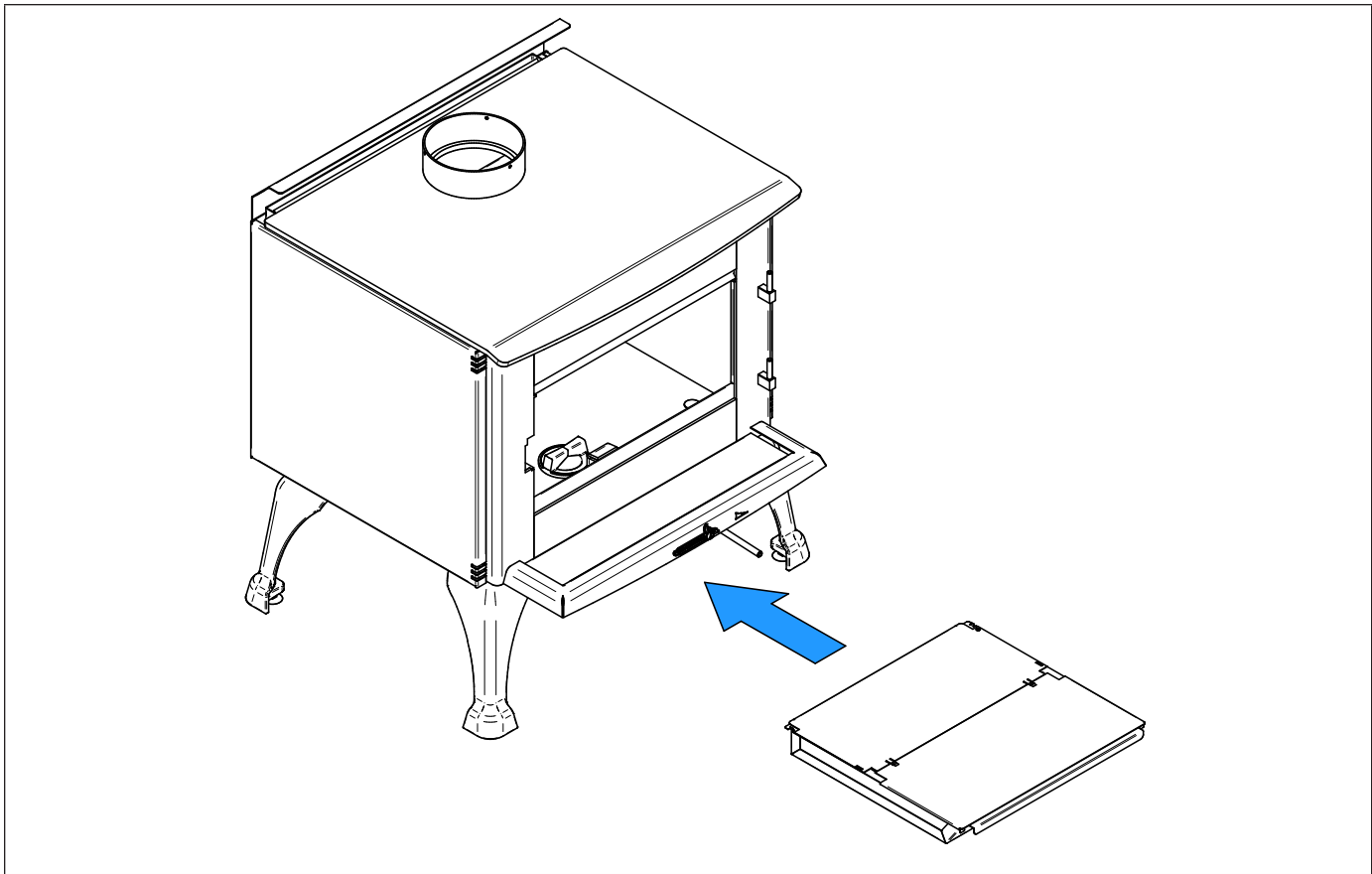

5. Put the stove on its legs, open and install the ash drawer included with the kit. Put back the firebricks, the spacers, the cast iron ash plug and the door on the stove. See step 1.

The baffle and the bricks must be put back at the right place after the final positioning of the stove

APPENDIX 2 : PEDESTAL INSTALLATION

ENGLISH

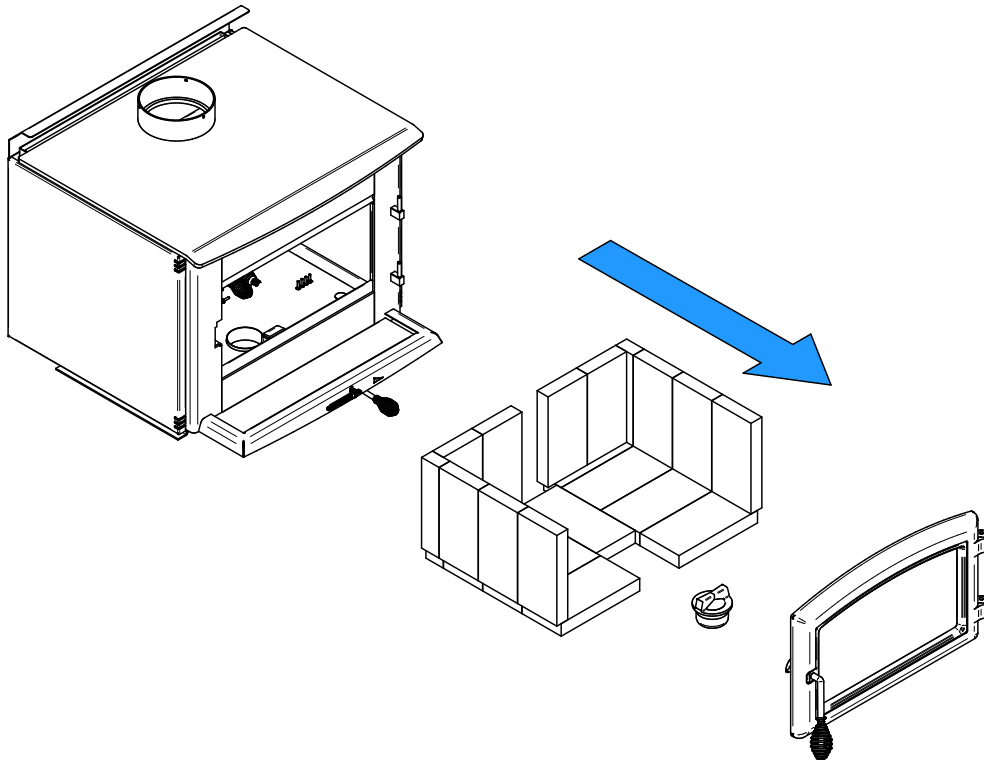

1. Remove the door, the firebricks, the spacers and the ash plug from the stove.

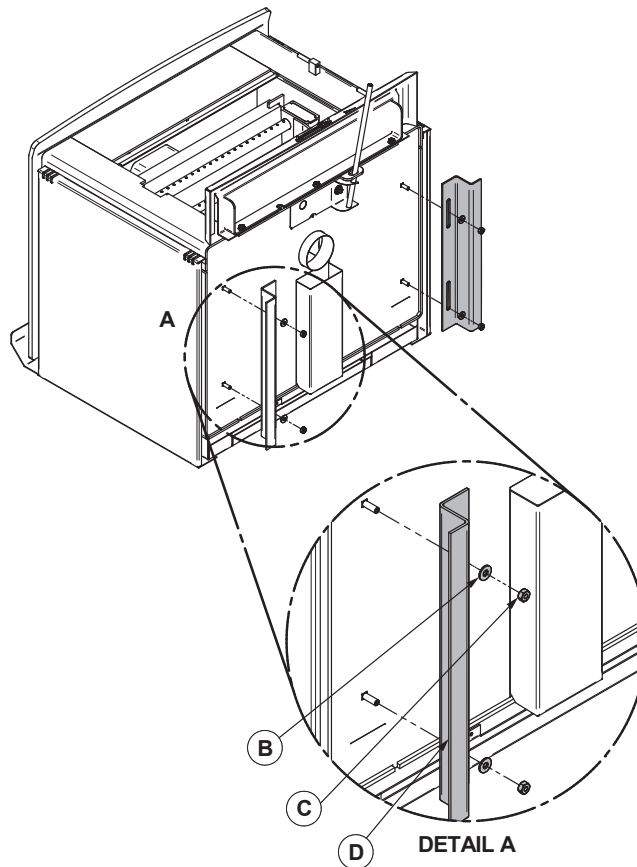

2. Put the stove on its back. Remove and dispose of the two freight supports **(D)**. Keep the nuts **(C)** and washers **(B)** for step 3.

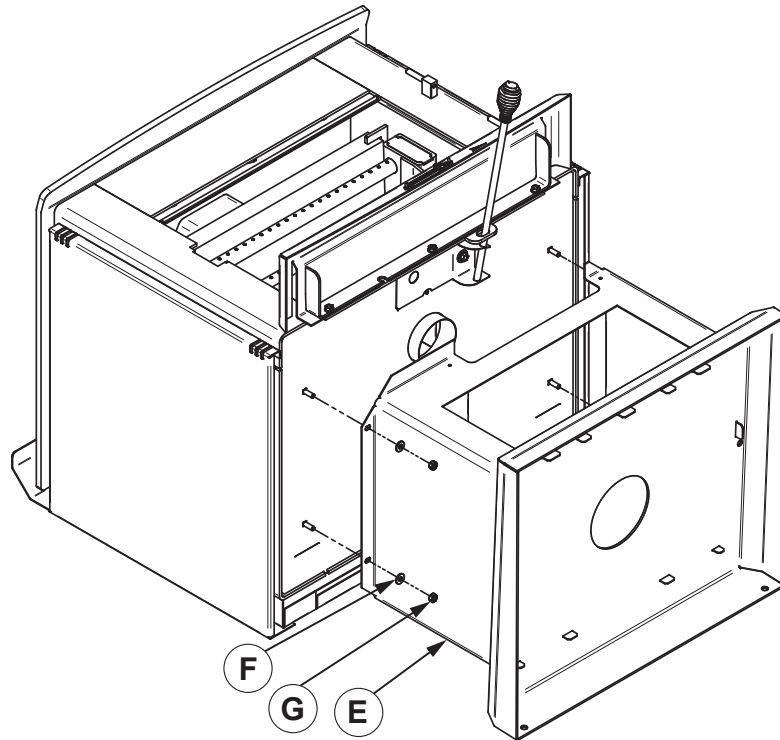

3. Install the pedestal **(E)** on the stove and screw it in place using the 4 the nuts **(G)** and washers **(F)** kept from step 2.

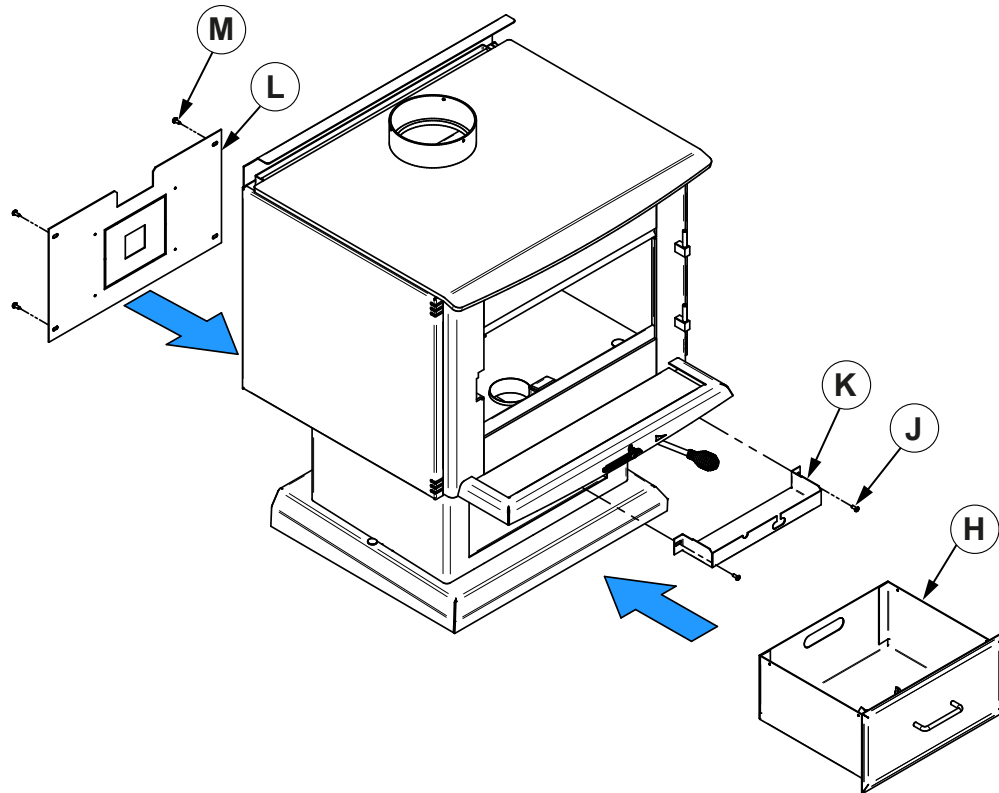

4. Put the stove on its pedestal and install the fresh air panel **(L)** with the screws **(M)**, the molding **(K)** with the screws **(J)** and install the ash drawer **(H)**. Put back the bricks, the spacers, the ash plug and the door on the stove. See step 1.

The baffle and the bricks must be put back at the right place after the final positioning of the stove

APPENDIX 3: DOOR OVERLAY INSTALLATION

Position the overlay **(A)** on the door frame and secure it in place from behind using the screws **(B)**. To ease the installation, do not tighten the screws until they are all installed.

ENGLISH

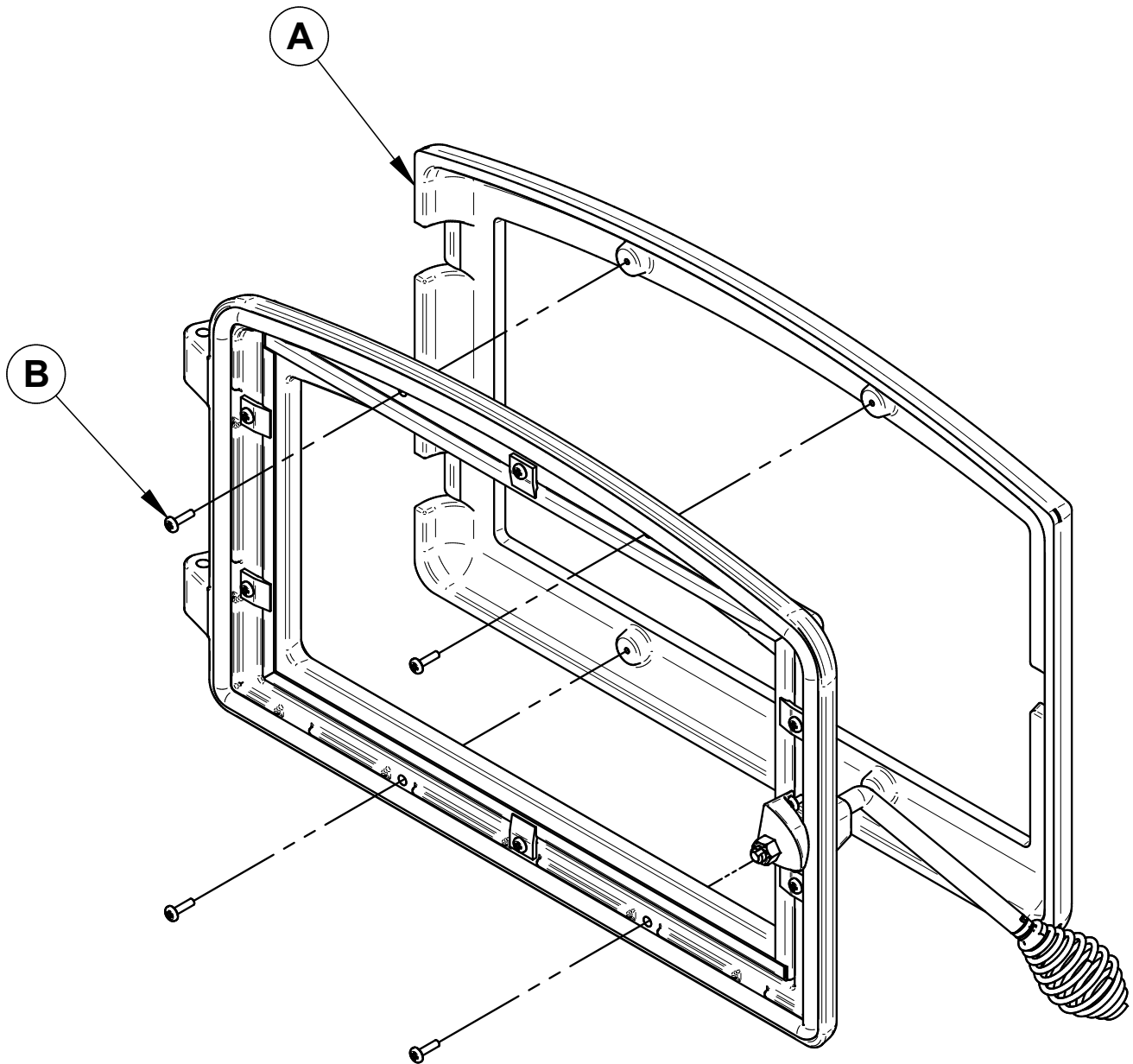

Note: It is not necessary to remove the glass to install the overlay.

APPENDIX 4: DECORATIVE ACCENT INSTALLATION

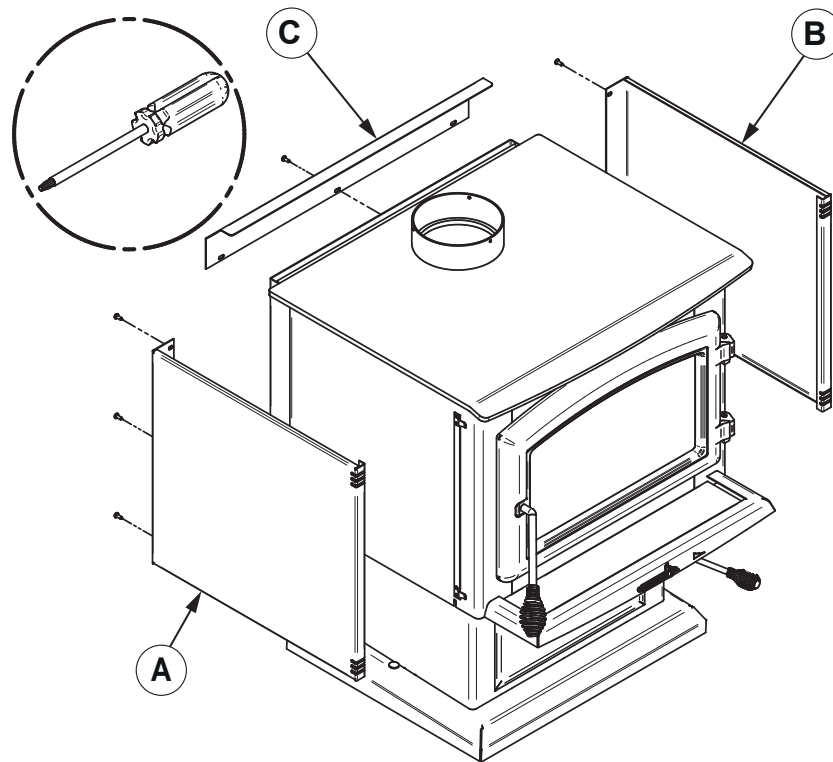

1. Remove both decorative panels **(A)** and **(B)** and also the heat deflector **(C)**.

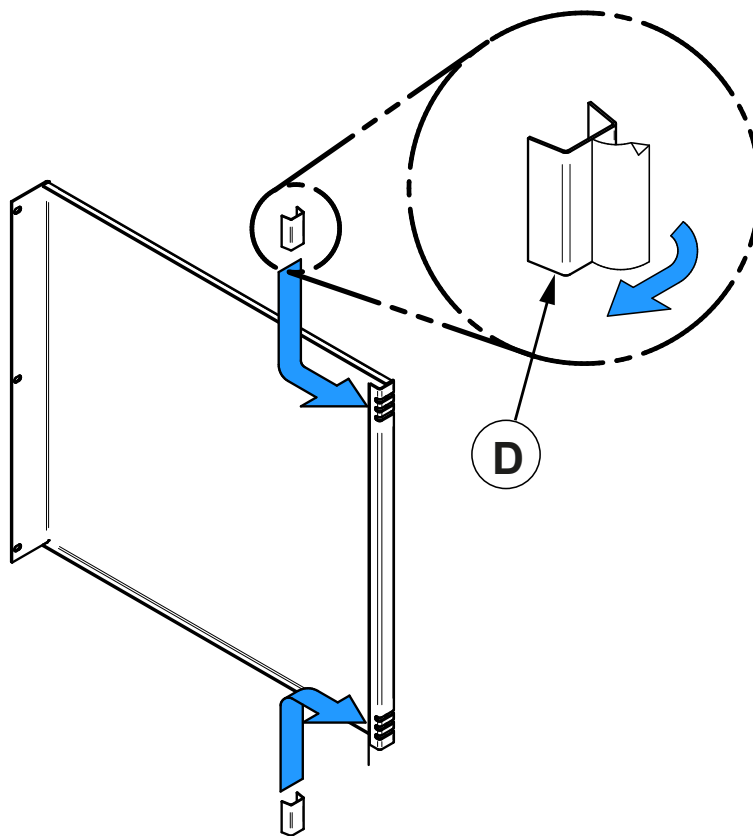

2. Remove the protective film and install the decorative accents **(D)** found in the user manual kit. Reinstall the decorative panels **(A)** and **(B)** first. Then the heat deflector **(C)**.

APPENDIX 5 : OPTIONAL AIR MATE INSTALLATION

This wood stove can be equipped with an optional air mate. It accumulates heat and increases the air flow.

ENGLISH

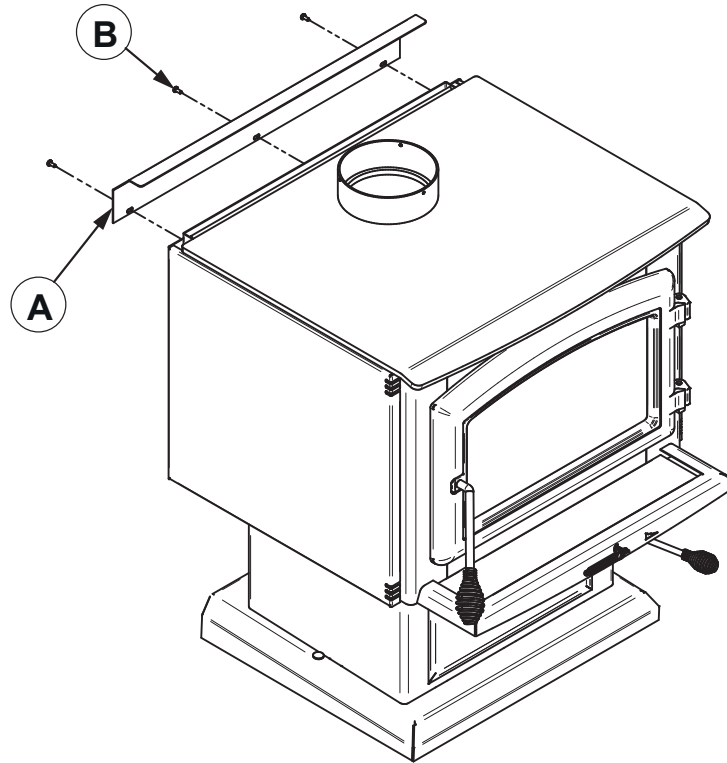

1. Remove the heat deflector **(A)**, keep the screws **(B)**.

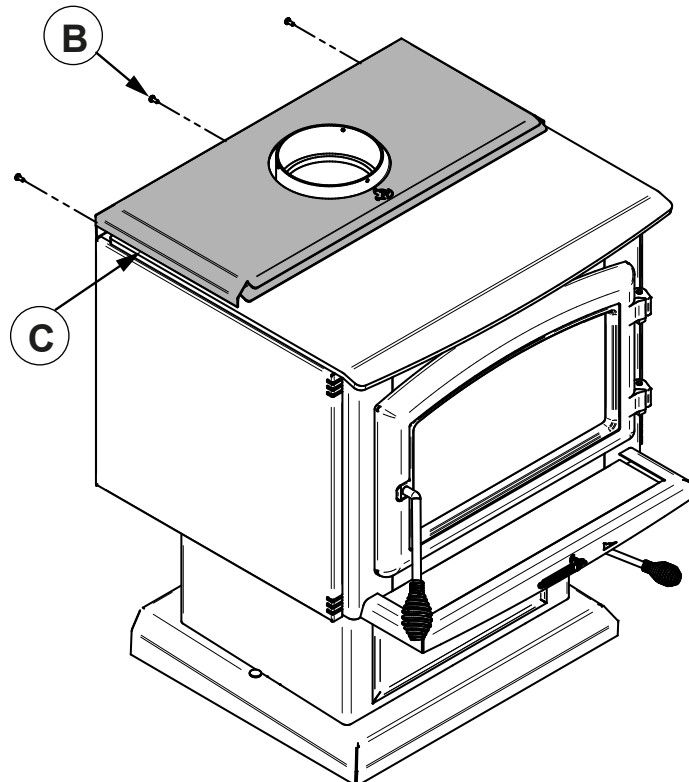

2. Install the air mate **(C)** and fix it in place using the 3 screws **(B)** removed previously

APPENDIX 6: OPTIONAL FRESH AIR INTAKE KIT INSTALLATION

This mobile home approved stove requires installation of a fresh air intake kit **(A)** and an insulated fresh air intake pipe (HVAC type, must meet ULC S110 or UL 181 class 0 or class 1) **(B)**, sold separately. Refer to air intake kit installation instructions for more details.

Installation with legs (AC01316)

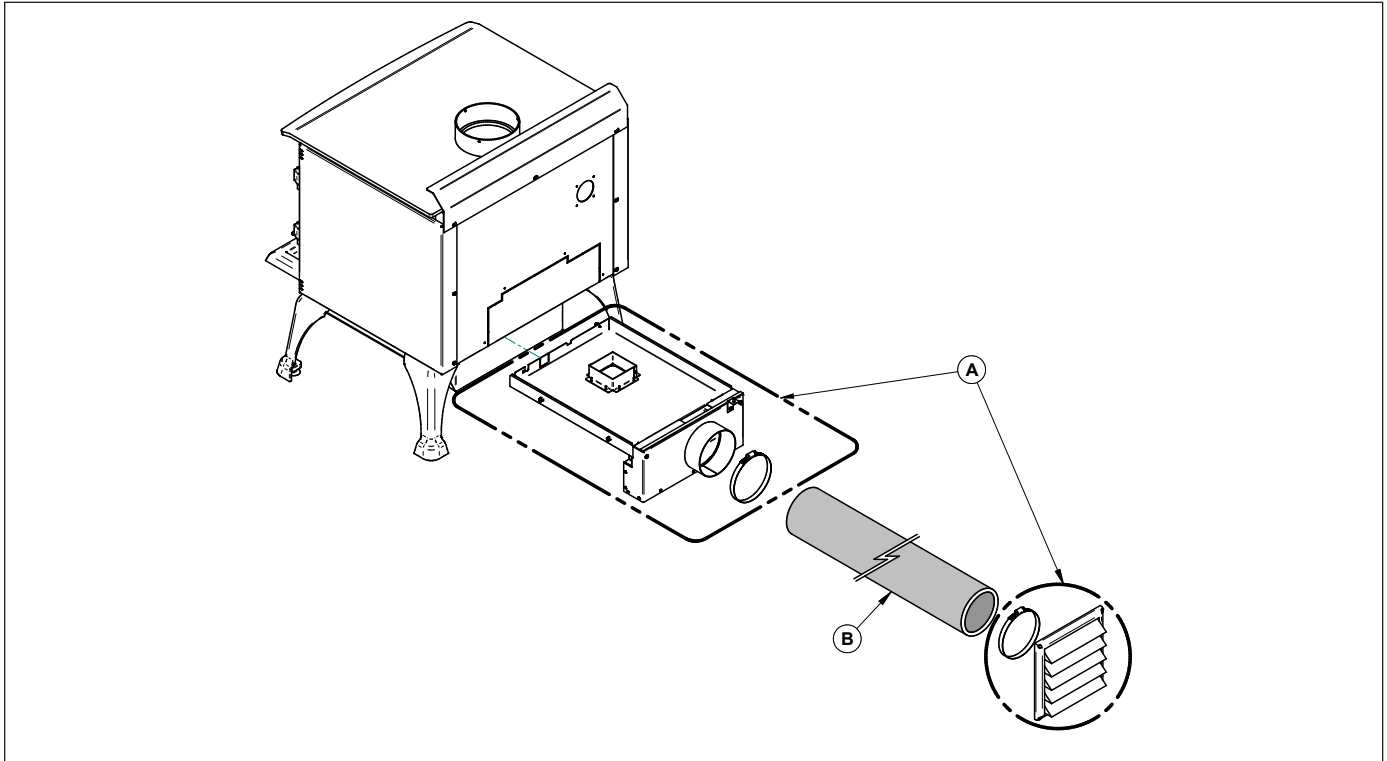

Installation with pedestal (AC01336)

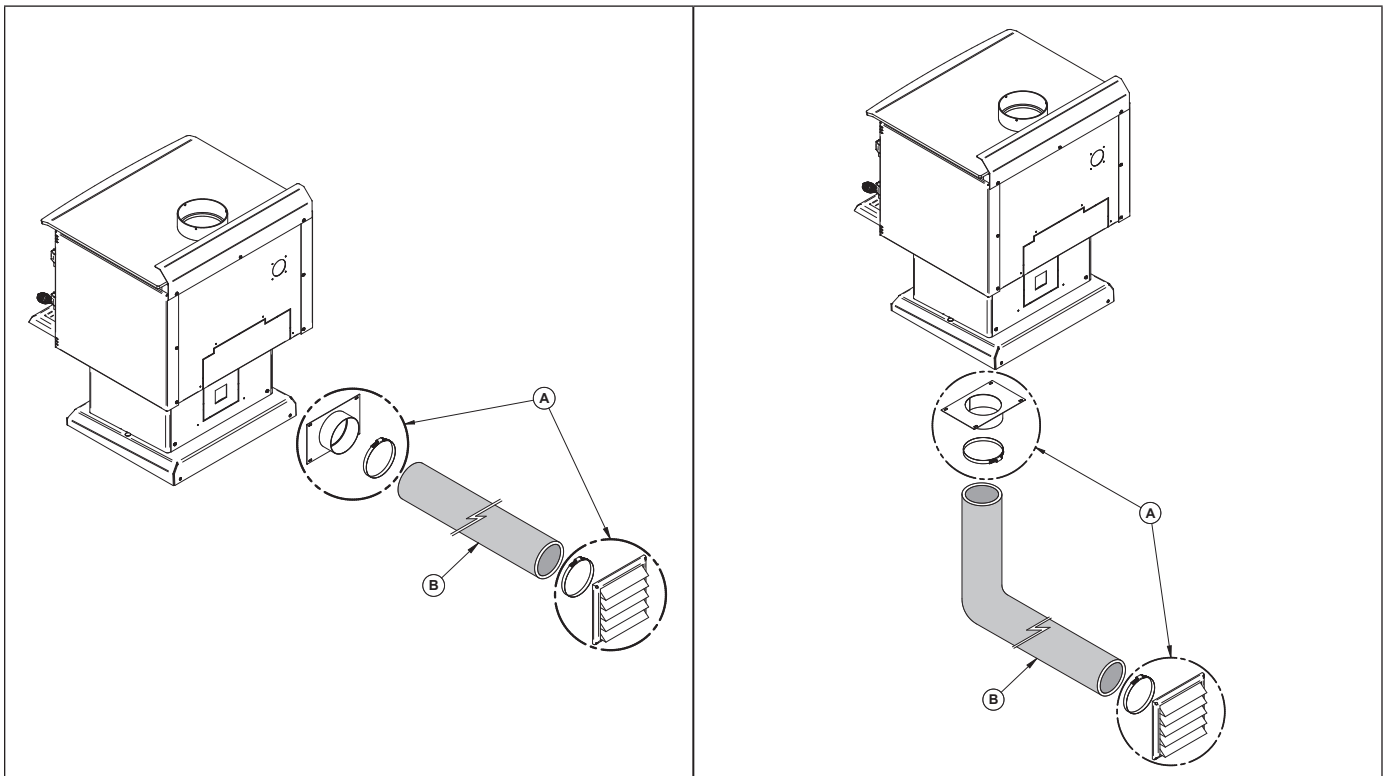

ENGLISH

APPENDIX 7: OPTIONAL FIRE SCREEN INSTALLATION

ENGLISH

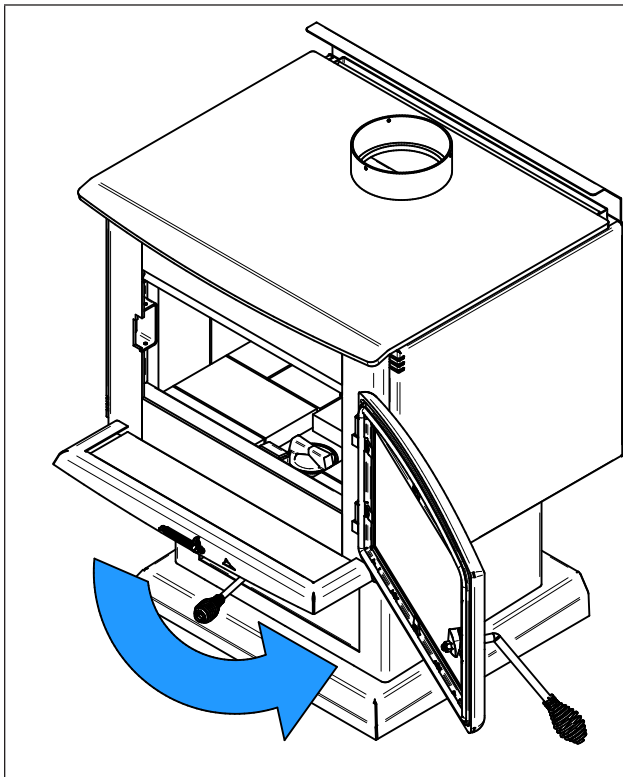

1. Open the door.

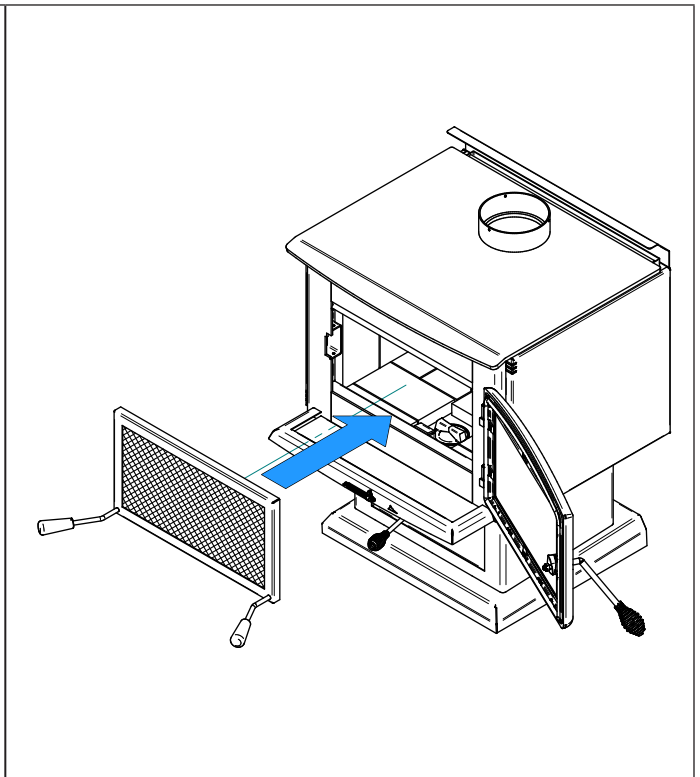

2. Hold the fire screen by the two handles and bring it close to the door opening.

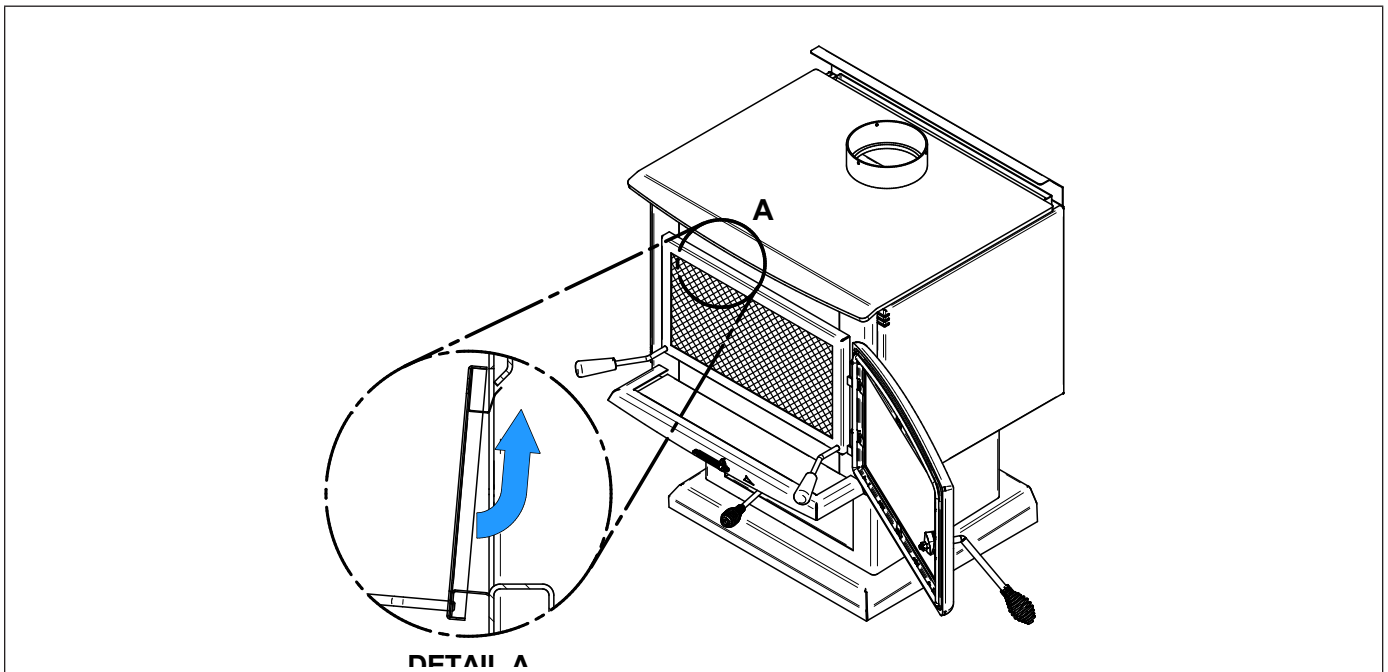

3. Lean the upper part of the fire screen against the top door opening making sure to shove the top fire screen brackets behind the primary air deflector.

4. Lift the fire screen upwards and push the bottom part towards the stove then let the fire screen rest on the bottom of the door opening.

Warning: Never leave the stove unattended while in use with the fire screen.

APPENDIX 8: OPTIONAL BLOWER AND THERMODISC INSTALLATION

A blower and a thermodisc, sold separately, can be installed on the stove. The installation of the blower is identical for a stove on legs or pedestal. Thermodisc allows the blower to operate only when the stove is hot enough. See the instructions provided with the thermodisc for more details.

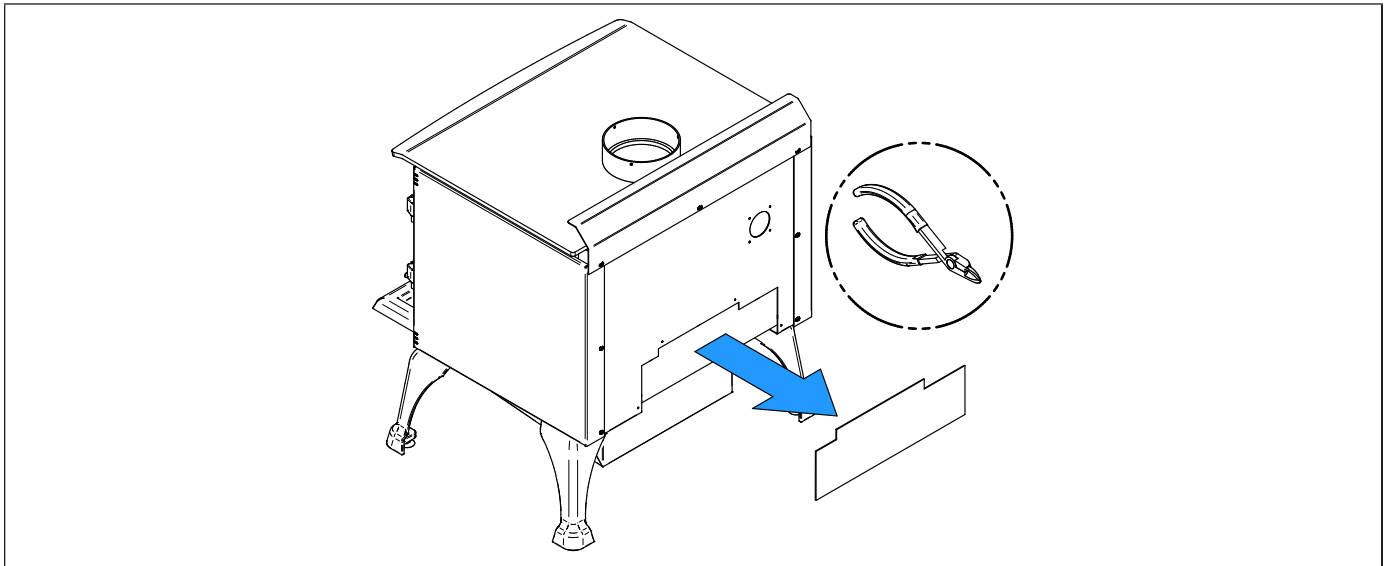

1. Remove the backplate by cutting the knockouts with pliers.

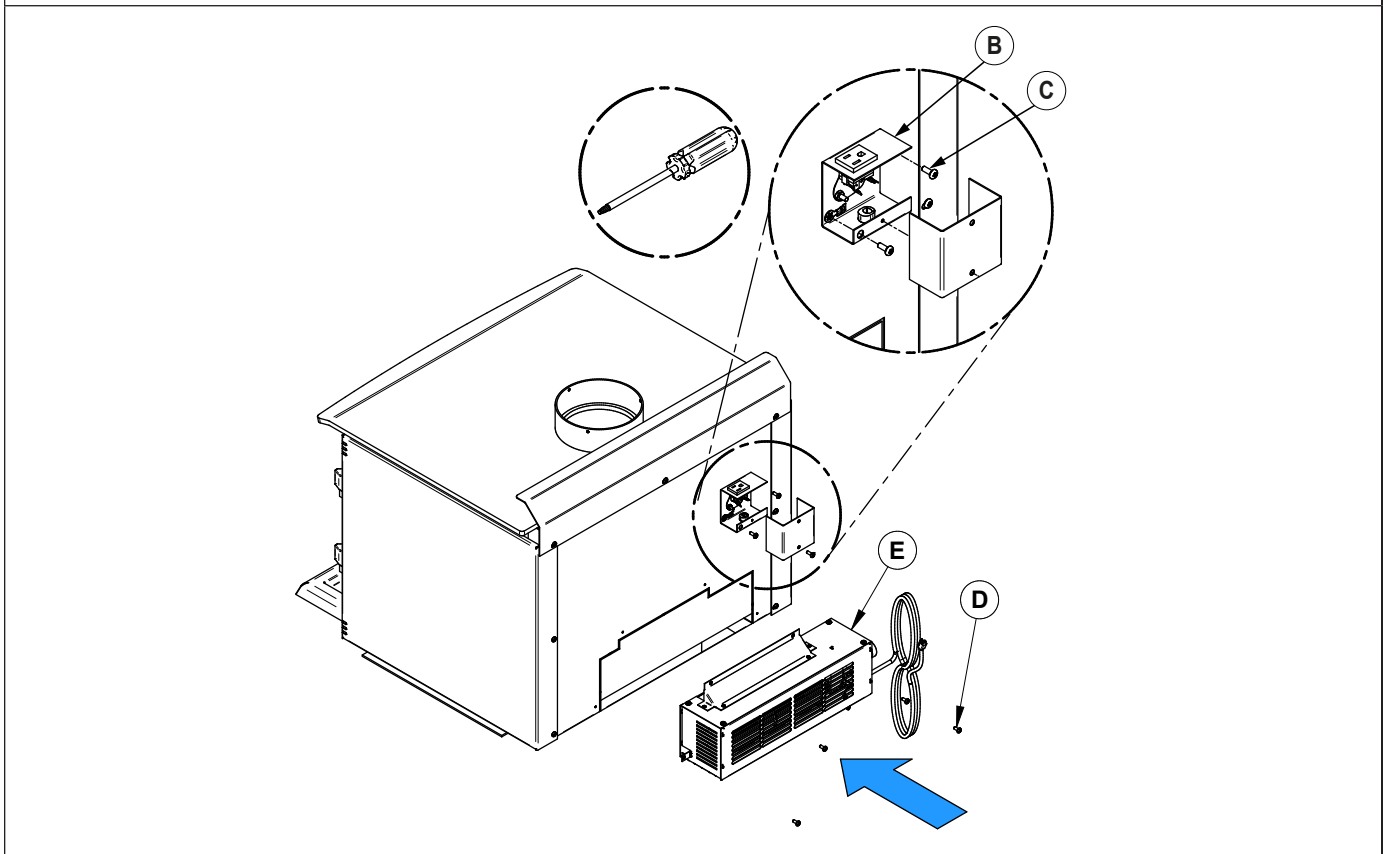

2. Screw the blower (E) in place using the screws (D) included in the installation manual. Screw the thermodisc (B) with the screws (C) supplied with the thermodisc on the back of the stove.

Ensure that the blower's power cord is not in contact with any surface of the stove to prevent electrical shock or fire damage. Do not run the power cord beneath the stove.

APPENDIX 9: AIR TUBES AND BAFFLE INSTALLATION

ENGLISH

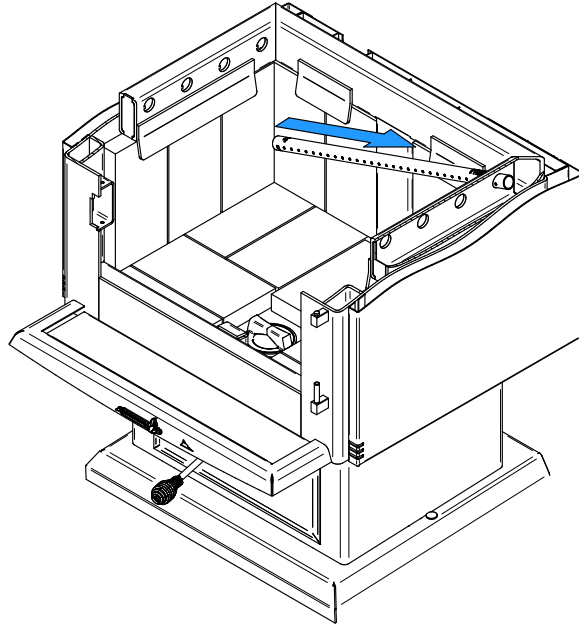

1. Starting with the rear tube, lean and shove the right end of the secondary air tube into the rear right channel hole. Then lift and shove the left end of the tube into the rear left channel.

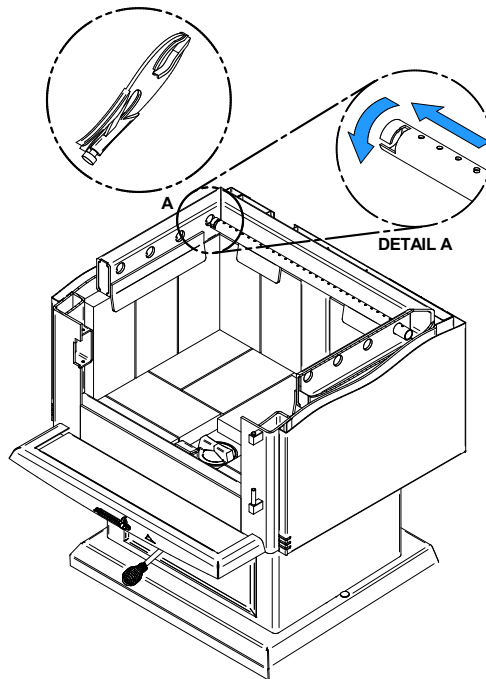

2. Align the notch in the left end of the tube with the key of the left air channel hole. Using a « Wise grip » hold the tube and lock it in place by turning the tube as shown in detail A . Make sure the notch reaches the end of the key way.
3. Repeat steps 1 and 2 for the two tubes in the back then install the baffle before installing the two front tubes.
4. To remove the tubes use the above steps in reverse order.

Note that secondary air tubes (B) can be replaced without removing the baffle board (A) and that all tubes are identical.

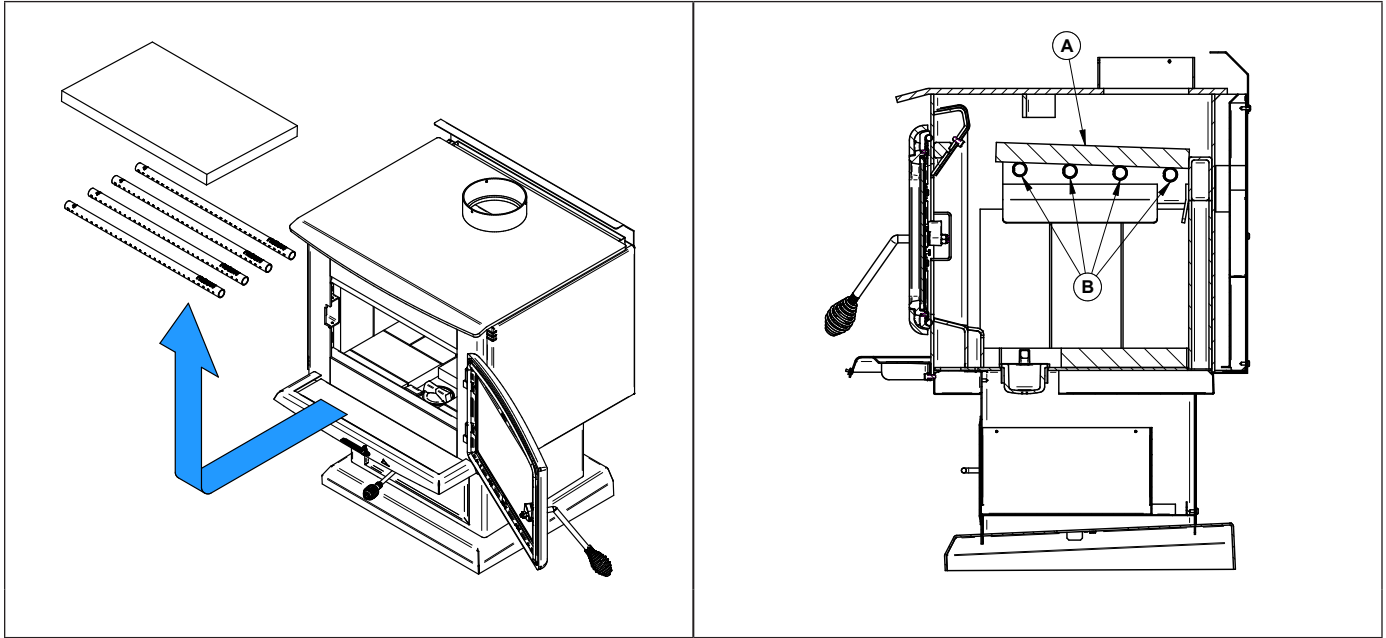

ENGLISH

APPENDIX 10: EXPLODED DIAGRAM AND PARTS LIST

ENGLISH

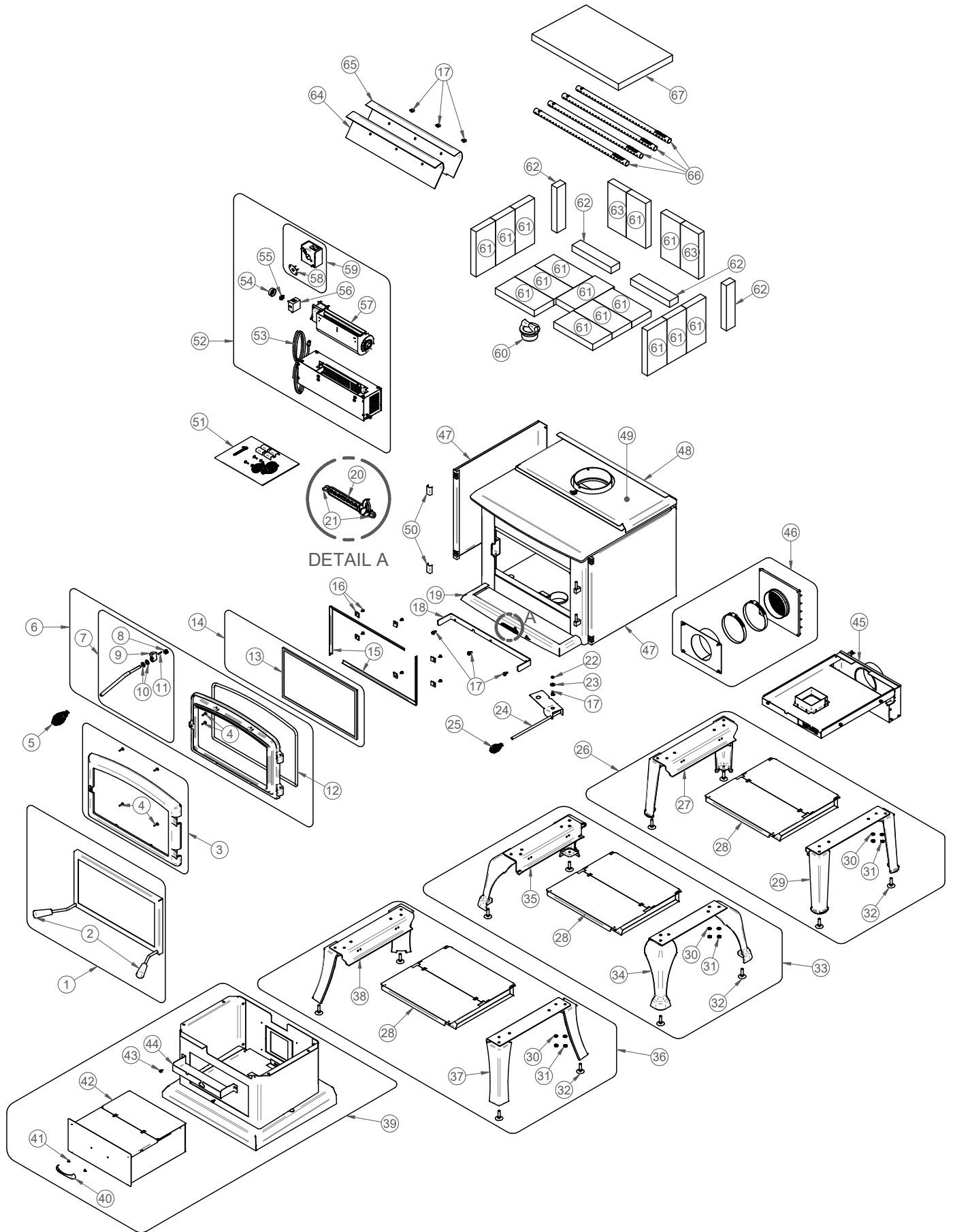

web

IMPORTANT: THIS IS DATED INFORMATION. When requesting service or replacement parts for your unit, please provide the model number and the serial number. We reserve the right to change parts due to technology upgrade or availability. Contact an authorized dealer to obtain any of these parts. Never use substitute materials. Use of non-approved parts can result in poor performance and safety hazards.

#	Item	Description	Qty
1	AC01315	RIGID FIRESCREEN	1
2	30569	ROUND WOODEN HANDLE BLACK	2
3	AC01254	BRUSHED NICKEL PLATED CAST IRON DOOR OVERLAY	1
3	AC01250	BLACK CAST IRON DOOR OVERLAY	1
4	30123	SCREW #8 - 32 X 5/8" PAN QUADREX ZINC	4
5	AC07868	1/2" BLACK COIL HANDLE	1
6	SE24102	CAST IRON DOOR WITH GASKET AND HANDLE	1
7	AC09169	HANDLE AND LATCH KIT SOLUTION 2.3	1
8	30224	LOCKNUT 3/8"-16 HEX	6
9	30033	STEEL DOOR LATCH	1
10	30205	ZINC WASHER ID 13/32" X OD 13/16"	2
11	30533	LATCH KEY PATH PIN	1
12	AC06000	SILICONE AND 1/2" X 8' BLACK DOOR GASKET KIT	1
13	AC06400	3/4" (FLAT) X 6' BLACK SELF-ADHESIVE GLASS GASKET	1
14	SE53582	GLASS WITH GASKET - 17 1/8"W X 9 13/16"H	1
15	PL53583	GLASS RETAINER FRAME	2
16	SE53585	GLASS RETAINER KIT WITH SCREWS (12 PER KIT)	1
17	30060	THREAD-CUTTING SCREW 1/4-20 X 1/2" F HEX STEEL SLOT WASHER C102 ZINC	4
18	PL65620	ASH LIP SUPPORT	1
19	SE65959	ASH LIP	1
20	30441	ENERZONE LOGO	1
21	30076	SEALING STEEL "POP" RIVET 1/8" X 3/8"	2
22	30187	STAINLESS WASHER ID 17/64" X OD 1/2"	1
23	30206	ZINC WASHER 5/16"ID X 3/4"OD	1
24	SE65727	AIR CONTROL DAMPER WITH ROD	1
25	AC07869	3/8" BLACK COIL HANDLE	1
26	AC01296	ROUND BRUSHED NICKEL PLATED CAST IRON LEG KIT	1
26	AC01295	ROUND BLACK CAST IRON LEG KIT	1
27	PL65878	LEG SUPPORT	2
28	SE65867	ASH PAN ASSEMBLY	1
29	24284-01	BRUSH NICKEL PLATED CAST IRON LEG (BLACK PAINT IN THE BACK)	4
29	24284	LEG HIGH NATURAL RAW CASTING WITHOUT PAINT	4
30	30185	17/64" AA TYPE WASHER	8
31	30100	BLACK HEX NUT 1/4 - 20	8
32	30050	LEVELING BOLT 3/8-16 X 1 1/2"	4

ENGLISH

#	Item	Description	Qty
33	AC01206	BLACK CAST IRON LEG WITH ASH PAN KIT	1
33	AC01208	BRUSH NICKEL PLATED CAST IRON LEG AND ASH PAN KIT	1
34	24012PN	BRUSH NICKEL PLATED CAST IRON LEG ENERZONE	4
34	24012	CAST IRON LEG WITH LEVELING BOLT	4
35	PL65531	LEG SUPPORT	2
36	AC01293	SQUARE BLACK CAST IRON LEG KIT	1
36	AC01294	SQUARE BRUSHED NICKEL PLATED CAST IRON LEG KIT	1
37	24283-01	BRUSH NICKEL PLATED CAST IRON LEG (BLACK PAINT IN THE BACK)	4
37	24283	LEG CURVED NATURAL RAW CASTING WITHOUT PAINT	4
38	PL65876	LEG SUPPORT	2
39	AC01125	PEDESTAL WITH ASH PAN KIT	1
40	28062	BLACK DRAWER HANDLE 3 25/32"	1
41	30108	MECHANICAL SCREW M4 X 4MM PAN PHILLIPS ZINC	2
42	SE65956	ASH PAN	1
43	30131	BLACK METAL SCREW #10 X 1/2" TYPE "A" PAN QUADREX	2
44	PL65529	AIR CONTROL COVER	1
45	AC01316	5"Ø FRESH AIR INTAKE KIT FOR WOOD STOVE ON LEGS	1
46	AC01336	5"Ø FRESH AIR INTAKE KIT FOR WOOD STOVE ON PEDESTAL	1
47	PL53523	LEFT OR RIGHT SIDE DECORATIVE PANEL	2
48	99999	BUILD TO ORDER	1
49	AC01230	AIRMATE	1
50	PL53550	NICKEL "U" SHAPED SIDE DECORATIVE ACCENT	4
51	SE45923	SOLUTION 2.3 INSTRUCTION MANUAL KIT	1
52	AC01000	130 CFM BLOWER WITH VARIABLE SPEED CONTROL (THERMODISC INCLUDED)	1
53	60013	POWER CORD 96" X 18-3 type SJT	1
54	44085	RHEOSTAT KNOB	1
55	44087	RHEOSTAT NUT	1
56	44080	RHEOSTAT WITHOUT NUT	1
57	44070	CROSSFLOW BLOWER SINGLE CAGE 115V-60Hz-56W	1
58	44028	CERAMIC THERMODISC F110-20F	1
59	AC05530	THERMODISC KIT	1
60	24096	ROUND CAST IRON ASH PLUG	1
61	29020	4 1/2" X 9" X 1 1/4" REFRACTORY BRICK HD	15
62	PL36056	2" X 9" 1 1/4" REFRACTORY BRICK	4
63	PL36636	4 1/4" X 9" 1 1/4" REFRACTORY BRICK	2
64	21387	TOP AIR DEFLECTOR INSULATION	1
65	PL65505	TOP AIR DEFLECTOR PROTECTOR	1
66	PL65514	SECONDARY AIR TUBE	4
67	21389	C-CAST BAFFLE 20" X 12 1/2" X 1 1/4"	1

ENERZONE LIMITED LIFETIME WARRANTY

The warranty of the manufacturer extends only to the original retail purchaser and is not transferable. This warranty covers brand new products only, which have not been altered, modified nor repaired since shipment from factory. Proof of purchase (dated bill of sale), model name and serial number must be supplied when making any warranty claim to your ENERZONE dealer.

This warranty applies to normal residential use only. This warranty is void if the unit is used to burn material other than cordwood (for which the unit is not certified by EPA) and void if not operated according to the owner's manual. Damages caused by misuse, abuse, improper installation, lack of maintenance, over firing, negligence or accident during transportation, power failures, downdrafts, venting problems or under-estimated heating area are not covered by this warranty. The recommended heated area for a given appliance is defined by the manufacturer as its capacity to maintain a minimum acceptable temperature in the designated area in case of a power failure.

This warranty does not cover any scratch, corrosion, distortion, or discoloration. Any defect or damage caused by the use of unauthorized or other than original parts voids this warranty. An authorized qualified technician must perform the installation in accordance with the instructions supplied with this product and all local and national building codes. Any service call related to an improper installation is not covered by this warranty.

The manufacturer may require that defective products be returned or that digital pictures be provided to support the claim. Returned products are to be shipped prepaid to the manufacturer for investigation. Transportation fees to ship the product back to the purchaser will be paid by the manufacturer. Repair work covered by the warranty, executed at the purchaser's domicile by an authorized qualified technician requires the prior approval of the manufacturer. All parts and labour costs covered by this warranty are limited according to the table below.

The manufacturer, at its discretion, may decide to repair or replace any part or unit after inspection and investigation of the defect. The manufacturer may, at its discretion, fully discharge all obligations with respect to this warranty by refunding the wholesale price of any warranted but defective parts. The manufacturer shall, in no event, be responsible for any uncommon, indirect, consequential damages of any nature, which are in excess of the original purchase price of the product. A one-time replacement limit applies to all parts benefiting from lifetime coverage. This warranty applies to products purchased after September 1st, 2015.

DESCRIPTION	WARRANTY APPLICATION*	
	PARTS	LABOUR
Combustion chamber (welds only) and cast iron door frame.	Lifetime	5 years
Ceramic glass (thermal breakage only**), plating (manufacturing defect**) and convector air-mate.	Lifetime	N/A
Surrounds, heat shields, ash drawer, steel legs, pedestal, trims (aluminum extrusions), C-Cast baffle**, vermiculite baffle**, secondary air tubes**, removable stainless steel combustion chamber, deflectors and supports.	7 years	N/A
Handle assembly, glass retainers and air control mechanism.	5 years	3 years
Removable carbon steel combustion chamber components.	5 years	N/A
Standard and optional blower, heat sensors, switches, rheostat, wiring and electronics.	2 years	1 year
Paint (peeling**), gaskets, insulation, ceramic fiber blankets, firebricks and other options.	1 year	N/A
All parts replaced under the warranty.	90 days	N/A

**Subject to limitations above. **Picture required.*

Labour cost and repair work to the account of the manufacturer are based on a predetermined rate schedule and must not exceed the wholesale price of the replacement part.

Shall your unit or a components be defective, contact immediately your **ENERZONE** dealer. To accelerate processing of your warranty claim, make sure to have on hand the following information when calling:

- Your name, address and telephone number;
- Bill of sale and dealer's name;
- Installation configuration;
- Serial number and model name as indicated on the nameplate fixed to the back of your unit;
- Nature of the defect and any relevant information.

Before shipping your unit or defective component to our plant, you must obtain an Authorization Number from your ENERZONE dealer. Any merchandise shipped to our plant without authorization will be refused automatically and returned to sender.

This document is available for free download on the manufacturer's website. It is a copyrighted document. Resale is strictly prohibited. The manufacturer may update this document from time to time and cannot be responsible for problems, injuries, or damages arising out of the use of information contained in any document obtained from unauthorized sources.



Stove Builder International inc.
250, rue de Copenhague,
St-Augustin-de-Desmaures (Québec) Canada
G3A 2H3
418-908-8002
<https://www.enerzone-intl.com/en/>
tech@sbi-international.com